

N750E INSTRUCTION MANUAL

Precautions

Keep this manual close to the handler responsible for the operation and maintenance inspection. Be sure to familiarize yourself with the handling manual before performing an inspection, and use it correctly according to the instructions of the instrument's knowledge, safety information, precautions, operation, and handling methods. Always observe the various specifications in the handbook. Also, perform the correct inspection and repair to prevent the failure.

Warranty for the unit

The warranty period for the delivery product is one year after delivery to the designated place of the order. In the event of a failure under normal use within the product specifications in accordance with this manual, the defect shall be replaced or repaired free of charge.

However, the warranty will be void if the fault is due to;

- (1) In case of unfair treatment and use by the consumer;
- (2) If the cause of failure is due to a reason other than the product supplied,
- (3) In case of modifications or repairs other than suppliers;
- (4) In case the supplier is not responsible for other natural disasters or disasters;

In addition, the warranty is for the inverter only, any damage caused to other equipment by malfunction of the inverter is not covered by the warranty.

Repair cost

Any repairs after the warranty period (1 year) will be paid. In addition, even during the warranty period, repairs for reasons other than the above warranty coverage and investigation into the cause of failure will be treated as a charge.

Please contact your place of purchase or service center – please refer to the list of back cover.

Questions on Unit

If you have any questions regarding damage to the unit, unknown parts or for general inquiries, please contact service center with the following information.

- (1) Date of purchase
- (2) Company name of purchase
- (3) Manufacturing number (MFG. No.)
- (4) Failure details (as detailed as possible)

CAUTION FOR UL/cUL REQUIREMENTS

- THE ADT CO., LTD N750E VFD UL FILE NUMBER IS E479086
CONFIRMATION OF UL LISTING CAN BE FOUND ON THE UL WEB SITE: www.ul.com
- DO NOT CONNECT OR DISCONNECT WIRING, OR PERFORM SIGNAL CHECKS WHILE THE POWER SUPPLY IS TURNED ON.
- THERE ARE LIVE PARTS INSIDE THE VFD. NEVER TOUCH THE PRINTED CIRCUIT BOARD (PCB) WHILE THE POWER SUPPLY IS TURNED ON.

[WARNING] THE BUS CAPACITOR DISCHARGE TIME IS 5 MINUTES. BEFORE STARTING WIRING OR INSPECTION, SWITCH POWER OFF, WAIT FOR MORE THAN 5 MINUTS, AND CHECK FOR RESIDUAL VOLTAGE BETWEEN TERMINAL P (+) AND N (-) WITH A METER ETC., TO AVOID HAZARD OF ELECTRICAL SHOCK.

[SHORT CIRCUIT RATING] THIS VFD IS SUITABLE FOR USE ON A CIRCUIT CAPABLE OF DELIVERING NOT MORE THAN ___*1___ARMS SYMMETRICAL AMPERES, 480 VOLTS FOR HF TYPE AND 240 VOLTS FOR LF TYPE MAXIMUM.

BRANCH CIRCUIT SHORT CIRCUIT PROTECTION SHALL BE PROVIDED BY FUSE ONLY.

*1 N750E MODELS and KA VALUE

N750E-004SF ~ N750E-022SF N750E-004LF ~ N750E-037LF N750E-004HF ~ N750E-037HF N750E-055LF/075LFP ~ N750E-150LF/185LFP N750E-055HF/075HFP ~ N750E-220HF/300HFP	5KA
---	-----

[OVERSPEED PROTECTION] THIS VFD DOES NOT PROVIDE OVERSPEED PROTECTION

[MOTOR OVERLOAD PROTECTION] THIS VFD PROVIDES MOTOR OVERLOAD PROTECTION. OVERLOAD PROTECTION LEVEL IS 20 ~ 120% OF FULL LOAD CURRENT. THE PROTECTION LEVEL MAY BE ADJUSTED BY PARAMETER (b04). REFER TO THE N750E USER GUIDE OR CATALOG.

[MOTOR OVERTEMPERATURE] MOTOR OVERTEMPATURE SENSING IS NOT PROVIDED BY THE VFD.

[ENVIRONMENT]

MAXIMUM AMBIENT TEMPERATURE	50°C (WHEN CARRIER FREQUENCY EQUAL TO OR LESS THAN DEFAULT VALUE)
AMBIENT HUMIDITY	90% RH OR LESS (NO CONDENSING)
STORAGE TEMPERATURE	-20~60°C
VIBRATION	5.9m/s ² OR LESS
ALTITUDE	ALTITUDE 1,000m OR LESS
AMBIENCE	INDOORS (NO CORROSIVE AND FLAMMABLE GASES, OIL MIST, DUST AND DIRT)
POLLUTION DEGREE	2

SAFETY

- FOR THE SAFE OPERATION OF THE N750E SERIES VFD, READ THIS MANUAL AND ALL OF THE WARNING SIGNS ATTACHED TO THE INVERTER CAREFULLY BEFORE INSTALLING AND OPERATING IT, AND FOLLOW THE INSTRUCTION EXACTLY. KEEP THIS MANUAL HANDY FOR YOUR QUICK REFERENCE.

SYMBOLS AND DEFINITION

- A SAFETY INSTRUCTION (MESSAGE) IS GIVEN WITH A HAZARD ALERT SYMBOL AND/OR A WARNING or CAUTION.
- EACH SIGNAL HAS THE FOLLOWING MEANING THROUGHOUT THIS MANUAL



HAZARDOUS HIGH VOLTAGE.

IT USED TO CALL YOUR ATTENTION TO ITEMS OR OPERATIONS THAT COULD BE DANGEROUS TO YOU OR OTHER PERSONS OPERATING THIS EQUIPMENT.

READ THESE MESSAGES AND FOLLOW THESE INSTRUCTIONS CAREFULLY.



SAFETY ALERT SYMBOL

THIS SYMBOL IS USED TO CALL YOUR ATTENTION TO ITEMS OR OPERATIONS THAT COULD BE DANGEROUS TO YOU OR OTHER PERSONS OPERATING THIS EQUIPMENT.

READ THESE MESSAGES AND FOLLOW THESE INSTRUCTIONS CAREFULLY.



WARNING

INDICATES A POTENTIALLY HAZARDOUS SITUATION WHICH, IF NOT AVOIDED, CAN RESULT IN SERIOUS INJURY OR DEATH.



CAUTION

INDICATES A POTENTIALLY HAZARDOUS SITUATION WHICH, IF NOT AVOIDED, CAN RESULT IN MINOR TO MODERATE INJURY, OR SERIOUS DAMAGE OF PRODUCT.

THE MATTERS DESCRIBED UNDER  **CAUTION** MAY, IF NOT AVOIDED, LEAD TO SERIOUS RESULTS DEPENDING ON THE SITUATION. IMPORTANT MATTERS ARE DESCRIBED IN **CAUTION** (AS WELL AS WARNING), SO BE SURE TO OBSERVE THEM.

NOTE

INDICATES AN AREA OR SUBJECT OF SPECIAL MERIT, EMPHASIZING EITHER THE PRODUCT'S CAPABILITIES OR COMMON ERRORS IN OPERATION OR MAINTENANCE.



HAZARDOUS HIGH VOLTAGE

- MOTOR CONTROL EQUIPMENT AND ELECTRONIC CONTROLLERS ARE CONNECTED TO THE HAZARDOUS LINE VOLTAGE.
- WHEN SERVICING VFD AND ELECTRONIC CONTROLLERS, THERE MIGHT BE EXPOSED COMPONENTS OR ABOVE LINE POTENTIAL.
- EXTREME CARE SHOULD BE TAKEN TO PRODUCT AGAINST SHOCK. STAND ON AN INSULATING PAD AND MAKE IT A HABIT TO USE ONLY ONE HAND WHEN CHECKING COMPONENTS.
- ALWAYS WORK WITH ANOTHER PERSON IN CASE AN EMERGENCY OCCURS.
- DISCONNECT POWER BEFORE CHECKING CONTROLLER OR PERFORMING MAINTENANCE.
- BE SURE EQUIPMENT IS PROPERLY GROUNDED. WEAR SAFETY GLASSES WHENEVER WORKING ON AN ELECTRIC CONTROLLER OR ROTATING ELECTRICAL EQUIPMENT.

PRECAUTION

- A SAFETY INSTRUCTION (MESSAGE) IS GIVEN WITH A HAZARD ALERT SYMBOL AND A WARNING or CAUTION.



WARNING THIS IS EQUIPMENT SHOULD BE INSTALLED, ADJUSTED AND SERVICED BY QUALIFIED ELECTRICAL MAINTENANCE PERSONAL FAMILIAR WITH THE CONSTRUCTION AND OPERATION OF THE EQUIPMENT AND THE HAZARDS INVOLVED. FAILURE TO OBSERVE THIS PRECAUTION COULD RESULTS IN BODILY INJURY.



WARNING THE USER IS RESPONSIBLE FOR ENSURING THAT ALL DRIVEN MACHINERY, DRIVE TRAIN MECHANISM NOT SUPPLIED BY HYUNDAI AND PROCESS LINE MATERIAL ARE CAPABLE OF SAFE OPERATION AT AN APPLIED FREQUENCY OF 150% OF THE MAXIMUM SELECTED FREQUENCY RANGE TO THE AC MOTOR. FAILURE TO DO SO CAN RESULT IN DESTRUCTION OF EQUIPMENT AND INJURY TO PERSONNEL SHOULD A SINGLE POINT FAILURE OCCUR.



WARNING FOR PROTECTION, INSTALL AN EARTH LEAKAGE BREAKER WITH A HIGH FREQUENCY CIRCUIT CAPABLE OF LARGE CURRENTS TO AVOID AN UNNECESSARY OPERATION. THE GROUND FAULT PROTECTION CIRCUIT IS NOT DESIGNED TO PROTECT PERSONAL INJURY.



CAUTION HEAVY OBJECT. TO AVOID MUSCLE STRAIN OR BACK INJURY, USE LIFTING AIDS AND PROPER LIFTING TECHNIQUES WHEN REMOVING OR REPLACING.



CAUTION THESE INSTRUCTIONS SHOULD BE READ AND CLEARLY UNDERSTOOD BEFORE WORKING ON N750E SERIES EQUIPMENT.



CAUTION PROPER GROUNDS, DISCONNECTING DEVICES AND OTHER SAFETY DEVICES AND THEIR LOCATION ARE THE RESPONSIBILITY OF THE USER AND ARE NOT PROVIDED BY HYUNDAI.



CAUTION BE SURE TO CONNECT A MOTOR THERMAL SWITCH OR OVERLOAD DEVICES TO THE N75E SERIES VFD TO ASSURE THAT INVERTER WILL SHUT DOWN IN THE EVENT OF AN OVERLOAD OR AN OVERHEATED MOTOR



CAUTION ROTATING SHAFTS AND ABOVE GROUND ELECTRICAL POTENTIALS CAN BE HAZARDOUS. THEREFORE, IT IS STRONGLY RECOMMENDED THAT ALL ELECTRICAL WORK CONFORM TO THE NATIONAL ELECTRICAL CODES AND LOCAL REGULATIONS. ONLY QUALIFIED PERSONNEL SHOULD PERFORM INSTALLATION, ALIGNMENT AND MAINTENANCE. FACTORY RECOMMENDED TEST PROCEDURES, INCLUDED IN THE INSTRUCTION MANUAL, SHOULD BE FOLLOWED. ALWAYS DISCONNECT ELECTRICAL POWER BEFORE WORKING ON THE UNIT.

NOTE: POLLUTION DEGREE 2

- THE VFD MUST BE USED IN THE ENVIRONMENT OF THE POLLUTION DEGREE 2.
- TYPICAL CONSTRUCTIONS THAT REDUCE THE POSSIBILITY OF CONDUCTIVE POLLUTION ARE,
 - 1) THE USE OF AN UNVENTILATED ENCLOSURE.
 - 2) THE USE OF A FILTERED VENTILATED ENCLOSURE WHEN THE VENTILATION IS FAN FORCED THAT IS, VENTILATION IS ACCOMPLISHED BY ONE OR MORE BLOWERS WITHIN THE ENCLOSURE THAT PROVIDE A POSITIVE INTAKE AND EXHAUST.

CAUTION FOR EMC (ELECTROMAGNETIC COMPATIBILITY)

TO SAFELY FOLLOW THE EMC DIRECTIVE AND TO COMPLY WITH STANDARDS, FOLLOWS THE CHECK LIST BELOW.



WARNING

THIS EQUIPMENT SHOULD BE INSTALLED, ADJUSTED, AND SERVICED BY QUALIFIED PERSONAL FAMILIAR WITH CONSTRUCTION AND OPERATION OF THE EQUIPMENT AND THE HAZARDS INVOLVED. FAILURE TO OBSERVE THIS PRECAUTION COULD RESULT IN BODILY INJURY.

1. THE POWER SUPPLY TO N750E INVERTER MUST MEET THESE SPECIFICATIONS
 - a. VOLTAGE FLUCTUATION: $\pm 10\%$ OR LESS.
 - b. VOLTAGE IMBALANCE: $\pm 3\%$ OR LESS.
 - c. FREQUENCY VARIATION: $\pm 4\%$ OR LESS.
 - d. VOLTAGE DISTORTION: THD = 10% OR LESS
2. INSTALLATION MEASURE :
 - a. USE A FILTER DESIGNED FOR N750E INVERTER
3. WIRING
 - a. SHIELDED WIRE (SCREENED CABLE) IS REQUIRED FOR MOTOR WIRING, AND THE LENGTH MUST BE LESS THAN 20 METERS.
 - b. THE CARRIER FREQUENCY SETTING MUST BE LESS THAN 5KHZ TO SATISFY EMC REQUIREMENTS.
 - c. SEPARATE THE MAIN CIRCUIT FROM THE SIGNAL/PROCESS CIRCUIT WIRING.
 - d. IN CASE OF REMOTE OPERATING WITH CONNECTOR CABLE, THE INVERTER DOES NOT CONFORM TO EMC
4. ENVIRONMENTAL CONDITIONS – WHEN USING A FILTER, FOLLOW THESE GUIDELINES:
 - a. AMBIENT AIR TEMPERATURE: $-10 - +50^{\circ}\text{C}$
 - b. HUMIDITY : 20 TO 90% RH(NON-CONDENSING)
 - c. VIBRATION : 5.9 M/S^2 (0.6G) 10 – 55HZ ((N750E-0.4kW(0.5 HP) ~ 22kW(30 HP)
 - d. LOCATION : 1000 METERS OR LESS ALTITUDE, INDOORS
(NO CORROSIVE GAS OR DUST)

CONFORMITY TO THE UNDERVOLTAGE DIRECTIVE (UVD)

THE PROTECTIVE ENCLOSURE MUST CONFORM TO THE UNDERVOLTAGE DIRECTIVE. THE VFD CAN CONFORM TO THE UVD BY MOUNTING INTO A CABINET OR BY ADDING COVERS AS FOLLOWS.

CABINET AND COVER

THE VFD MUST BE INSTALLED INTO A CABINET WHICH HAS THE PROTECTION DEGREE OF TYPE IP2X.
IN ADDITION THE TOP SURFACES OF CABINET ARE EASILY ACCESSIBLE SHALL MEET AT LEAST THE REQUIREMENTS OF THE PROTECTIVE TYPE IP4X, OR WHICH IS CONSTRUCTED TO PREVENT SMALL OBJECTS FROM ENTERING INVERTER.

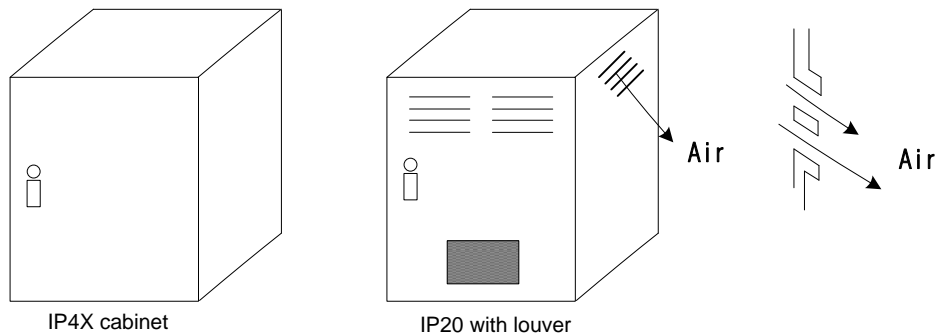

Fig 1. INVERTER CABINET

UL WARNINGS AND CAUTIONS MANUAL FOR N750E SERIES

- THIS AUXILIARY INSTRUCTION MANUAL SHOULD BE DELIVERED TO THE END USER.

1. WIRE MARKING FOR ELECTRICAL PRACTICE AND WIRE SPECIFICATIONS

“USE COPPER CONDUCTOR ONLY, 75 °C WITH A TORQUE RATING.

2. TIGHTENING TORQUE AND WIRE RANGE

TIGHTENING TORQUE AND WIRE RANGE FOR FIELD WIRING TERMINALS ARE MARKED ADJACENT TO THE TERMINAL OR ON THE WIRING DIAGRAM.

MODEL NAME N750E - Heavy Duty/Normal Duty	TIGHTENING TORQUE [LB-IN]	WIRE RANGE		RING TERMINAL SIZE MAXIMUM WIDTH [inch]
		AWG	kcmil	
N750E-004SF	8.7	14	4.1	0.228
N750E-004LF	8.7	14	4.1	0.228
N750E-007SF	8.7	14	4.1	0.228
N750E-007LF	8.7	14	4.1	0.228
N750E-015SF	15.9	12	6.5	0.315
N750E-015LF	8.7	14	4.1	0.228
N750E-022SF	15.9	10	10.4	0.315
N750E-022LF	15.9	12	6.5	0.315
N750E-037LF	15.9	10	10.4	0.315
N750E-004HF	15.9	14	4.1	0.315
N750E-007HF	15.9	14	4.1	0.315
N750E-015HF	15.9	14	4.1	0.315
N750E-022HF	15.9	14	4.1	0.315
N750E-037HF	15.9	12	6.5	0.315
N750E-055LF/075LFP	12.4	8	16.5	0.4
N750E-075LF/110LFP	12.4	8	16.5	0.4
N750E-110LF/150LFP	26.6	6	41.7	0.51
N750E-150LF/185LFP	26.6	4	41.7	0.51
N750E-055HF/075HFP	12.4	12	6.53	0.4
N750E-075HF/110HFP	12.4	10	10.4	0.4
N750E-110HF/150HFP	26.6	8	16.5	0.51
N750E-150HF/185HFP	26.6	8	16.5	0.51
N750E-185HF/220HFP	26.6	8	16.5	0.51
N750E-220HF/300HFP	26.6	6	26.3	0.51

3. FUSE SIZE

DISTRIBUTION FUSE SIZE INFORMATION IS SHOWN IN THE TABLE BELOW. THE FUSE MUST BE A UL LISTED, 600V, INVERSE TIME RATED FUSE WITH THE CURRENT RATINGS SHOWN BELOW

MODEL NAME	FUSE [A]
N750E -004SF	10
N750E -004LF	6
N750E -007SF	15
N750E -007LF	10
N750E -015SF	25
N750E -015LF	15
N750E -022SF	30
N750E -022LF	20
N750E -037LF	30
N750E -004HF	3
N750E -007HF	6
N750E -015HF	10
N750E -022HF	15
N750E -037HF	20
N750E -055LF/075LFP	50
N750E -075LF/110LFP	60
N750E -110LF/150LFP	80
N750E -150LF/185LFP	100
N750E -055HF/075HFP	20
N750E -075HF/110HFP	30
N750E -110HF/150HFP	40
N750E -150HF/185HFP	50
N750E -185HF/220HFP	60
N750E -220HF/300HFP	80

General Safety Information

A SAFETY INSTRUCTION (MESSAGE) INCLUDES A HAZARD ALERT SYMBOL AND A SIGNAL WORD, DANGER OR CAUTION. EACH SIGNAL WORD HAS THE FOLLOWING MEANING: THIS SYMBOL IS THE "SAFETY ALERT SYMBOL." IT OCCURS WITH EITHER OF TWO SIGNAL WORDS: DANGER OR CAUTION, AS DESCRIBED BELOW.

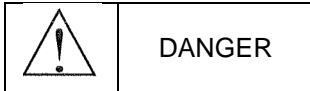

: INDICATES A POTENTIALLY HAZARDOUS SITUATION WHICH, IF NOT AVOIDED, CAN RESULT IN SERIOUS INJURY OR DEATH.

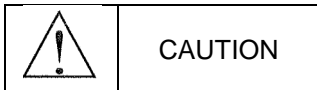

: INDICATES A POTENTIALLY HAZARDOUS SITUATION WHICH, IF NOT AVOIDED, CAN RESULT IN MINOR TO MODERATE INJURY, OR SERIOUS DAMAGE TO THE PRODUCT.

THE SITUATION DESCRIBED IN THE CAUTION MAY, IF NOT AVOIDED, LEAD TO SERIOUS RESULTS. IMPORTANT SAFETY MEASURES ARE DESCRIBED IN CAUTION (AS WELL AS DANGER), SO BE SURE TO OBSERVE THEM.

CAUTION

- All illustrations in this handbook may be depicted with the cover or blockage removed to explain the details. When operating the machine, operate the machine in accordance with the handling manual, with the specified covers.
- No notification is given if the contents change due to product improvement or manual re-organization. The changes are indicated by the number in the revised manual.
- If you have lost or damaged the manual, please contact your dealer or your nearest dealer.
- Product damage caused by user arbitrary operation is not within the scope of maintenance and is not liable for it.

General Safety Information

1. Installation

CAUTION

- Be sure to install the unit on flame resistant material such as metal.
- Be sure not to place anything highly flammable in the vicinity.
- Do not carry unit by top cover, always carry by supporting base of unit.
- Be sure not to let foreign matter enter VFD such as cut wire refuse, spatter from welding, iron refuse, wire, dust, etc.
- Be sure to install inverter in a place which can support the weight according to the specifications in the text. (Chapter 2. Installation)
- Be sure to install the unit on a perpendicular wall which is not subject to vibration
- Be sure not to install and operate a VFD which is damaged or has parts which are missing.
- Be sure to install the inverter in an area which is not exposed to direct sunlight and is well ventilated. Avoid environments which tend to be high in temperature, high in humidity or to have condensation, as well as places with dust, corrosive gas, explosive gas, highly flammable gas, grinding-fluid mist, salt damage, etc.

2. Wiring

CAUTION

- Be sure to ground the unit.
Electrical wiring work should be carried out by qualified electricians.
- Do the wiring work by an electrician.
There is a possibility of electric shock and fire.
- Check the input power OFF before wiring.
There is a possibility of electric shock and fire.
- Be sure to attach the main body and wire it.
There are concerns of electric shock and injury.

General Safety Information

CAUTION

- Make sure that the rated voltage and AC power voltage of the product match.
There are concerns about accidents and fires.
- Do not use single phase input.
There is a fire hazard.
- Do not connect AC power to the output terminals (U,V,W).
Risk of injury and fire.
- Tighten to the specified torque of the screw. Check that the screws are not loose.
There is a fire hazard.
- Install a short circuit breaker on the input side.
There is a fire hazard.
- Install the fuse in the operating circuit (same as main power).
There is a fire hazard.
- Use power lines, short-circuit breakers and electronic contactors at the specified capacity (qualification).
There is a fire hazard.

3. Control and Operation

CAUTION

- Be sure to put the input power after you remove the front cover.
Do not open the cover while it is energized.
There is a possibility of electric shock.
- Do not operate the switch with wet hands.
There is a possibility of electric shock.
- Do not contact the inverter terminals during powering or shutdown of the inverter.
There is a possibility of electric shock.
- If retriever mode is selected, a sudden restart will occur even the inverter stopped by trip.
(Please designed a machine can protect with retriever mode.)
Please keep away from the machine. There are concerns of an accident.
- If a short power outage occurs, the driver's command can be entered to re-run after the power outage. If there is a possibility of danger to a person, use the circuit that is not re-driving after power-up. There are concerns of an accident.
- STOP keys are valid only when the function is set.
Prepare the emergency stop switch separately. There are concerns of an accident.
- Do not set the alarm reset with the operation command together, it will re-start without caution.
Make sure operation command is off and set the alarm rest.
There are concerns of an accident.
- Do not put any contacts or sticks inside the inverter while it is on.
There is a possibility of electric shock and fire.

General Safety Information

CAUTION

- The heat sink fins will have a high temperature. Be sure not to touch them..
There is a risk of burns.
- Low to high speed operation of the inverter can be easily set. Be sure to operate it after checking the tolerance of the motor and machine.
There are concerns of an accident.
- Install an external braking system if needed.
There are concerns of an accident.
- If the motor needs to operate at a frequency higher than standard Max Frequency setting (50Hz/60Hz), be sure to check with the manufacturers of both the motor and the machine for their approval.
There is a concern of machine failure.
- Check the following before and during the test run.
Was the direction of the motor correct?
Were the RPM and frequency motor correct?
Were there any abnormal motor vibrations or noises?
- The AC reactor must be installed when the power is not stable in order to avoid damage to the VFD.
- Do not switch drive inputs when starting or stopping the motor.
Turning the drive on and off often shortens the life of the drive.
Damage to the DC bus charging circuit and the DC bus capacitor may result in premature drive failure.
For maximum performance, the maximum number of charging cycles (i.e. power-up by power supply) of the DC capacitor is:
Less than five times in ten minutes.

4. Maintenance, Inspection and Part Replacement

CAUTION

- After turning off the input power supply, do not perform the maintenance and inspection for at least 10 minutes.
There is a possibility of electric shock.
- Make sure that only qualified persons will perform maintenance, inspection and/or part replacement.
(Before starting the work, remove metallic objects (wristwatch, bracelet, etc.)
(Be sure to use insulated tools.)

5. Others

CAUTION

- Never modify the unit.
There is a possibility of electric shock and accident.

CONTENTS

SAFETY	III
SYMBOLS AND DEFINITION	III
PRECAUTION	IV
NOTE: POLLUTION DEGREE 2.....	V
CONFORMITY TO THE UNDERVOLTAGE DIRECTIVE (UVD)..	VII
CABINET AND COVER	VII
1. Installation	XI
2. Wiring	XI
3. Control and Operation.....	XII
4. Maintenance, Inspection and Part Replacement	XIII
5. Others.....	XIII
CONTENTS.....	XIV
1. GENERAL INFORMATION	1-1
1.1 Inspection on purchase.....	1-1
1.1.1 Product inspection	1-1
1.1.2 Instruction manual	1-2
1.2 Inquiry and warranty.....	1-2
1.2.1 Inquiry	1-2
1.2.2 Warranty of unit	1-2
1.2.3 N750E-004SF~007SF, 004LF~015LF	1-3
1.2.4 N750E-015SF~022SF, 022LF, 004HF~022HF	1-4
1.2.5 N750E-037LF, 037HF	1-5
1.2.6 N750E-055LF/075LFP ~ 075LF/110LFP, 055HF/075HFP ~ 075HF/110HFP	1-6
1.2.7 N750E -110LF/150LFP, 110HF/150HFP ~ 150HF/185HFP	1-7
1.2.8 N750E-150LF/185LFP, 185HF/220HFP ~ 220HF/300HFP	1-8
2. INSTALLATION AND WIRE.....	2-1
2.1 Installation.....	2-1
2.1.1 Precaution	2-2
2.2 Wiring.....	2-4
2.2.1 0.4kW ~ 3.7kW Terminal connection diagram and description	2-5
2.2.2 5.5kW ~ 22kW Terminal connection diagram and description	2-6

2.2.3	Main circuit terminal description	2-7
2.2.4	Main circuit terminal description	2-8
2.2.5	Main circuit terminal wiring	2-9
2.2.6	Control circuit terminal description	2-11
2.2.7	Control circuit terminal wiring	2-13
2.2.8	Accessory wiring	2-17
2.2.9	Torque and wire specification	2-19

3. SPECIFICATION 3-1

3.1	Specification	3-1
3.1.1	200V Class specification	3-1
3.1.2	400V Class specification	3-2
3.1.3	Performance specification	3-3
3.1.4	Braking resistor specification	3-5
3.2	Dimension	3-6
3.2.1	N750E-004SF~007SF, 004LF~015LF	3-6
3.2.2	N750E-015SF~022SF, 022LF, 004HF~022HF	3-7
3.2.3	N750E-037LF, 037HF	3-8
3.2.4	N750E-055LF/075LFP~075LF/110LFP, 055HF/075HFP~075HF/110HFP	3-9
3.2.5	N750E-110LF/150LFP, 110HF/150HFP~150HF/185HFP	3-10
3.2.6	N750E-150LF/185LFP, 185HF/220HFP~220HF/300HFP	3-11

4. OPERATION 4-1

4.1	Keypad overview	4-2
4.1.1	Keypad description	4-2
4.1.2	Keypad navigation	4-3
4.1.3	Shift key function	4-7
4.2	Frequency and run sources	4-8
4.2.1	Control terminal operation	4-8
4.2.2	Digital keypad operation	4-8
4.2.3	Combination control terminal and digital keypad	4-8
4.2.4	Communication (RS-485) operation	4-8
4.3	Test run	4-9
4.3.1	To input the operation setting and the frequency setting from the terminal	4-9
4.3.2	Operation setting and the frequency setting from the digital operator	4-11

5. PARAMETERS 5-1

5.1	Parameter Group Overview	5-1
5.1.1	Monitoring (d group)	5-1
5.1.2	Trip monitor (d group)	5-1
5.1.3	Basic function (F group)	5-2
5.1.4	Extended function A mode (A group)	5-3
5.1.5	Extended function b mode (b group)	5-9
5.1.6	Extended function C mode (C group)	5-15
5.1.7	Motor (H group)	5-19
5.2	d Group Parameters	5-20
5.3	F Group Parameters	5-22
5.4	A Group Parameters	5-23

5.5	B Group Parameters	5-40
5.6	C Group Parameters	5-61
5.7	H Group Parameters	5-81
6.	COMMUNICATION	6-1
7.	PROTECTIVE FUNCTION	7-1
8.	TROUBLESHOOTING TIPS	8-1
9.	MAINTENANCE AND INSPECTION.....	9-3
9.1	General precautions and notes	9-3
9.2	Inspection items	9-3
	Recommend spare parts for stocks.....	9-4
	Inverter electrical measurements	9-5

1. GENERAL INFORMATION

1.1 Inspection on purchase

1.1.1 Product inspection

Please inspect following before installation.

- (1) No damage made to the unit during transportation?
- (2) One Instruction manual is enclosed?
(0.4kw to 3.7kw inverter Instruction manual is not enclosed, Instruction manual can be viewed as a QR code.)
- (3) Check the label specification if the correct product is delivered per your order.

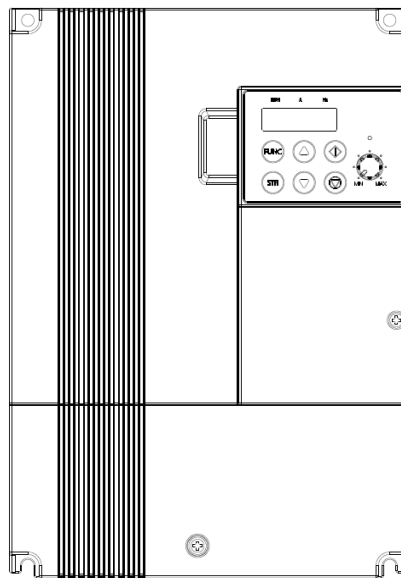

Figure 1-1 Outlook of N750E

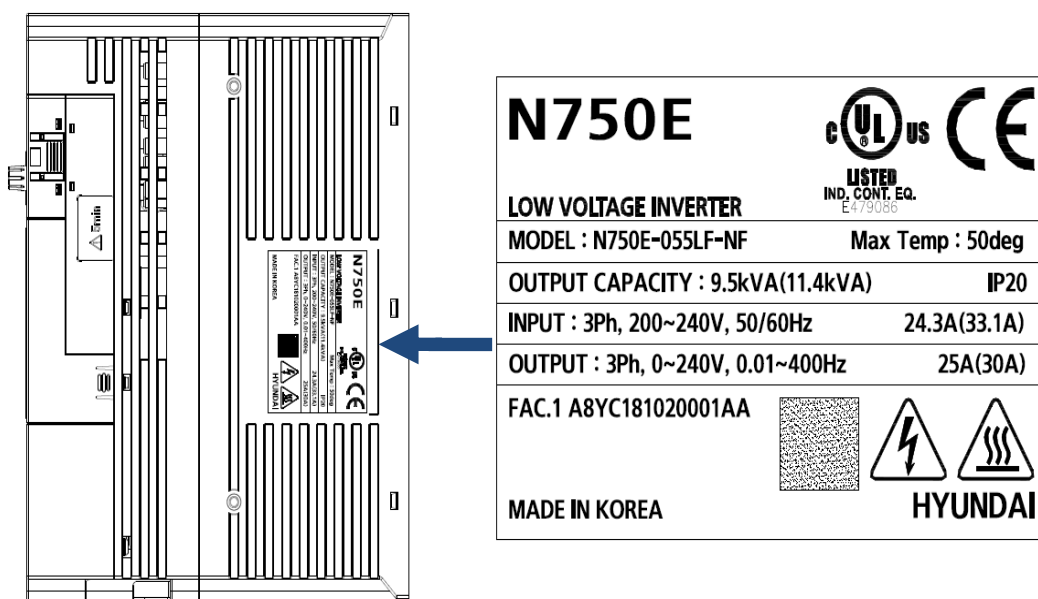

Figure 1-2 N750E Specification on label

1.1.2 Instruction manual

This instruction manual is for the N750E series.

Carefully read the manual before operating the inverter and please read this manual and keep it as a reference.

In addition, this manual is intended to be delivered to the final user.

1.2 Inquiry and warranty

1.2.1 Inquiry

- If you have any questions about damage to the inverter, unknown parts, or other information, please contact the place of purchase with the following information.

- (1) Product model name
- (2) Manufacturing number (MFG. No.)
- (3) Date of purchase
- (4) Failure details (as detailed as possible)
 - Damaged parts, condition, etc.
 - Unknown parts, condition, etc.

1.2.2 Warranty of unit

- The warranty period for the delivery product is one year after delivery.
However, the warranty will be void if the fault is due to;
 - (1) In case of unfair treatment and use by the consumer
 - (2) If the cause of failure is due to a reason other than the product supplied
 - (3) When using a product that is out of specification
 - (4) In case the supplier is not responsible for other natural disasters (earthquake, lightning)
- Since the warranty mentioned here means the inverter itself, the damage caused by the inverter failure shall not be liable.
- After warranty period, the entire test or repair will be charged.
Any failure caused by above mentioned items within the warranty period will be claimed.
Please contact your place of purchase for any problems that have occurred within the warranty period

1.2.3 N750E-004SF~007SF, 004LF~015LF

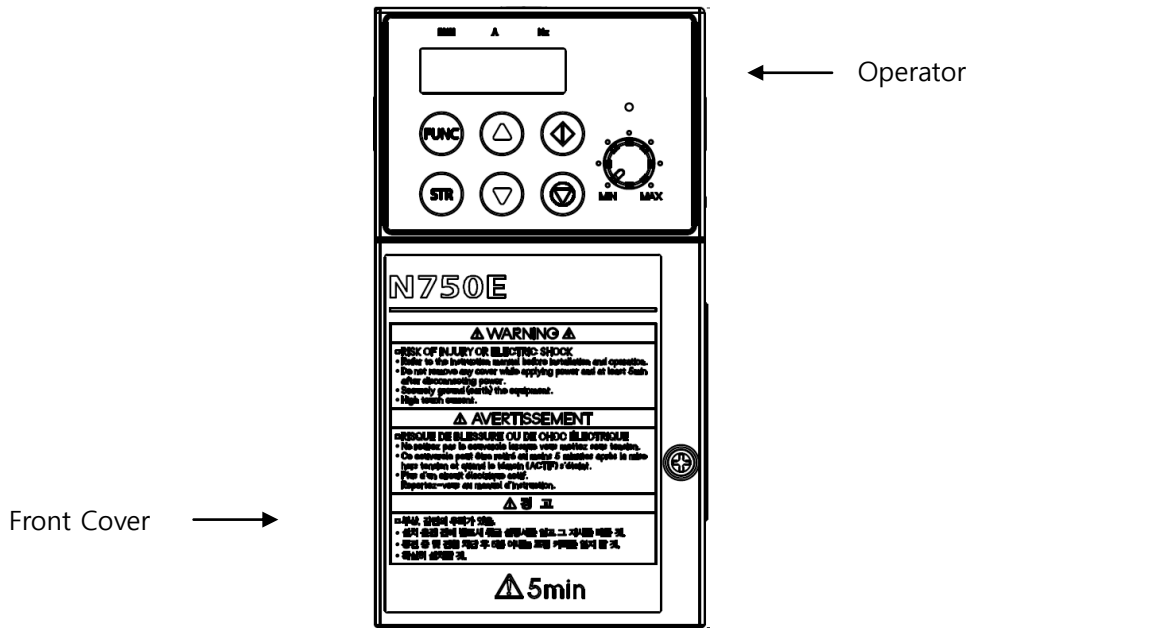

Figure 1-3 Front view with front cover

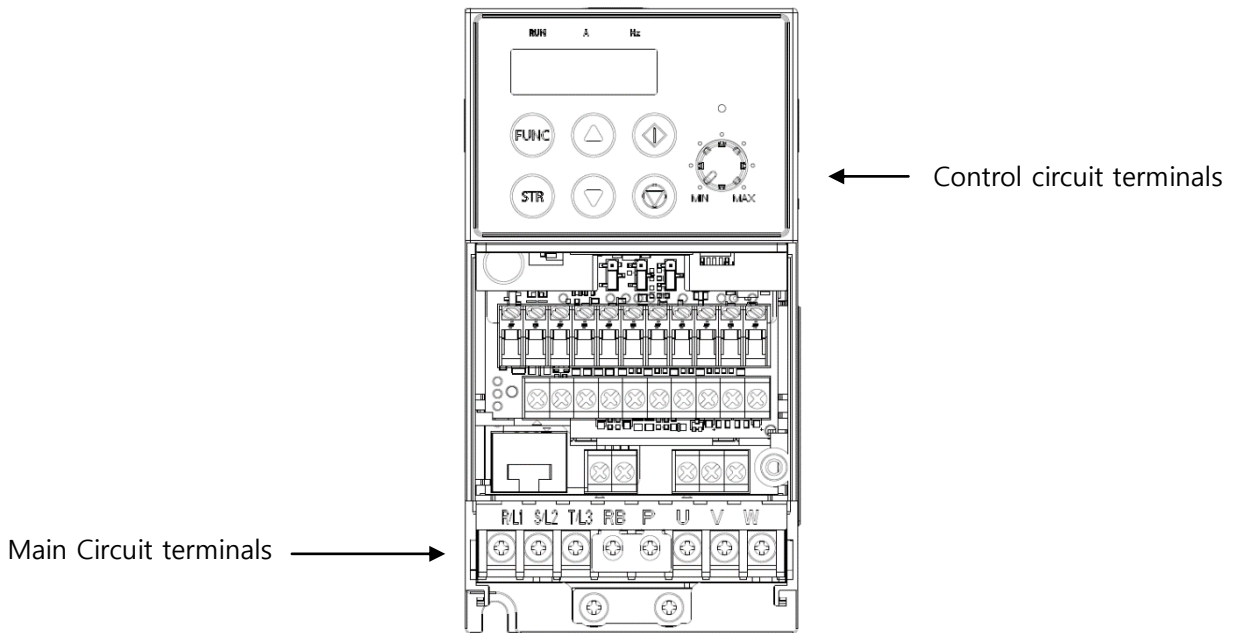

Figure 1-4 Front view without front cover

1.2.4 N750E-015SF~022SF, 022LF, 004HF~022HF

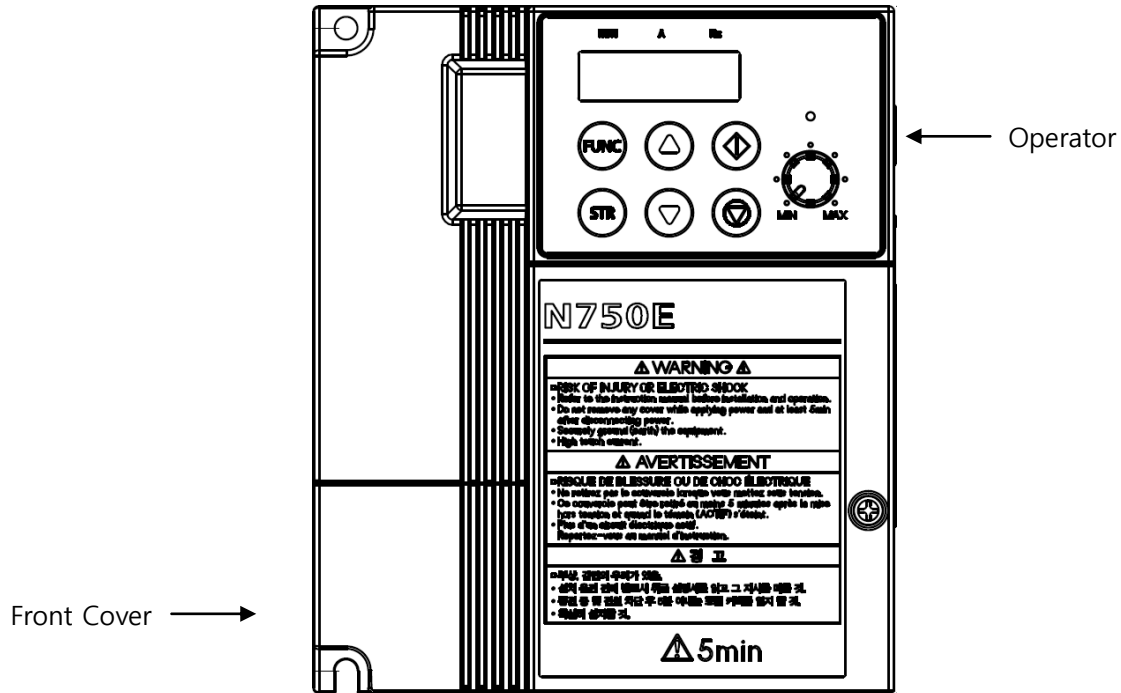

Figure 1-5 Front view with front cover

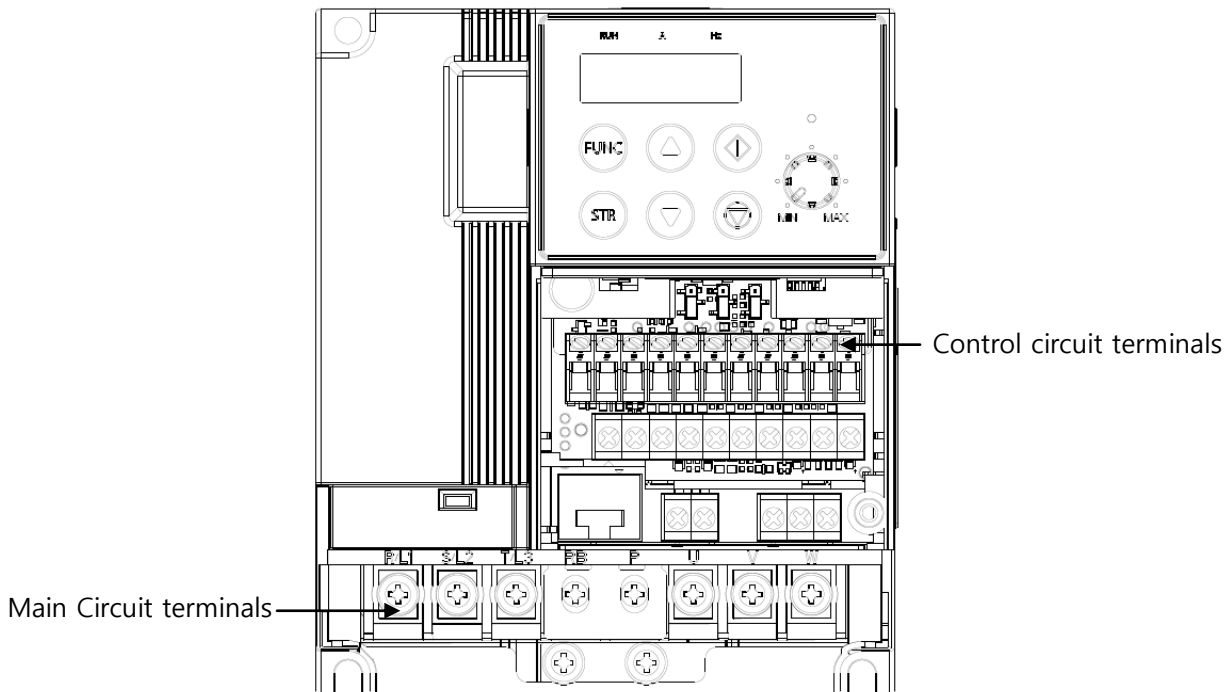

Figure 1-6 Front view with front cover

1.2.5 N750E-037LF, 037HF

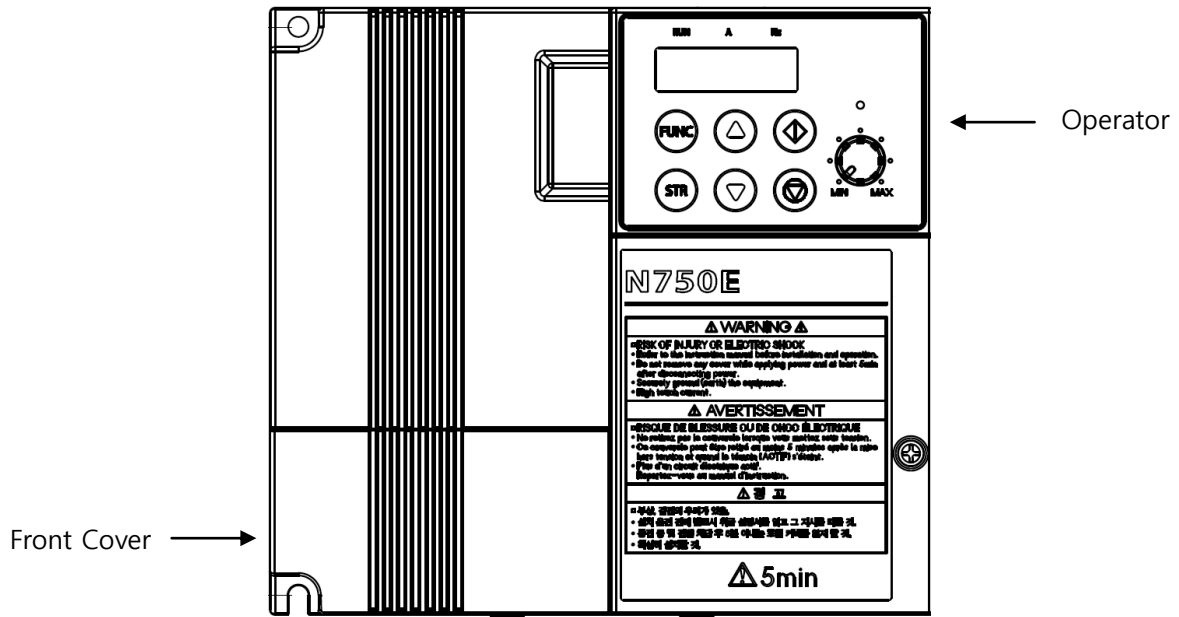

Figure 1-7 Front view with front cover

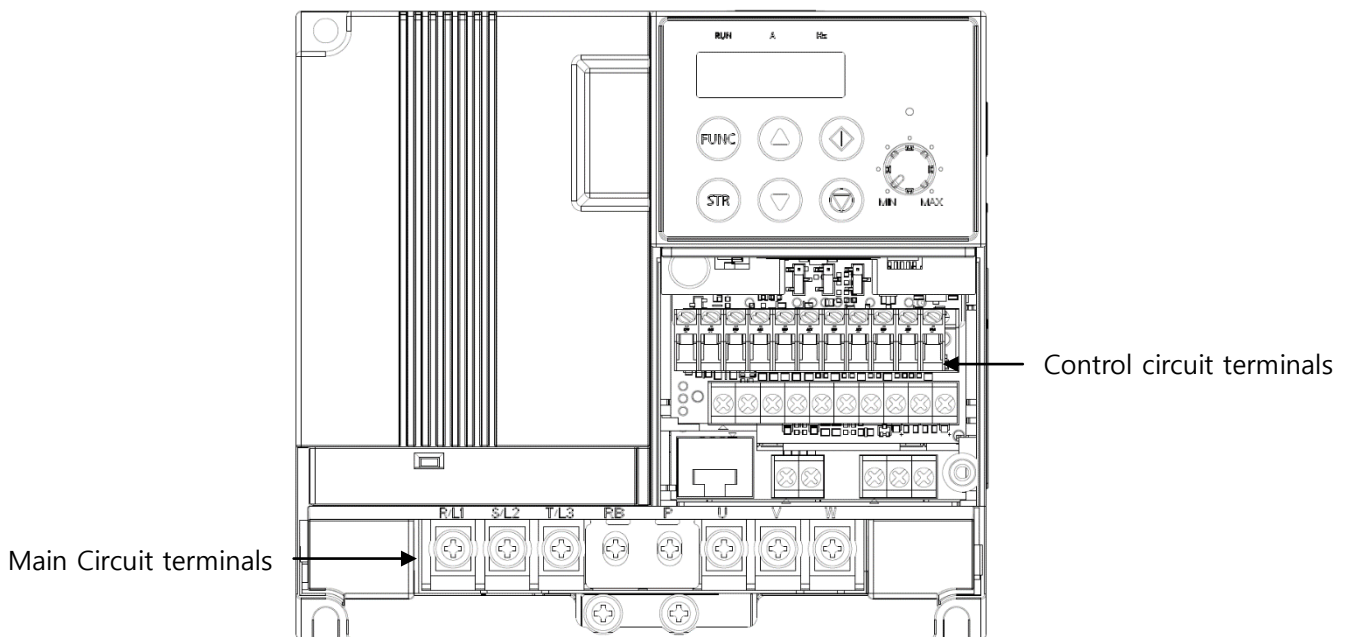

Figure 1-8 Front view without front cover

1.2.6 N750E-055LF/075LFP ~ 075LF/110LFP, 055HF/075HFP ~ 075HF/110HFP

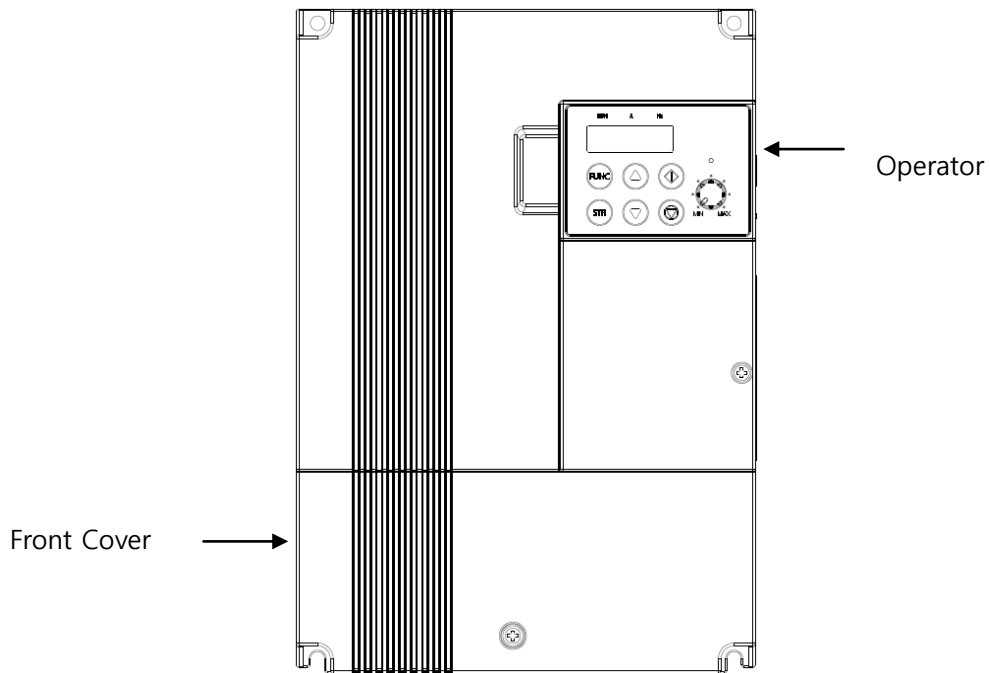

Figure 1-9 Front view with front cover

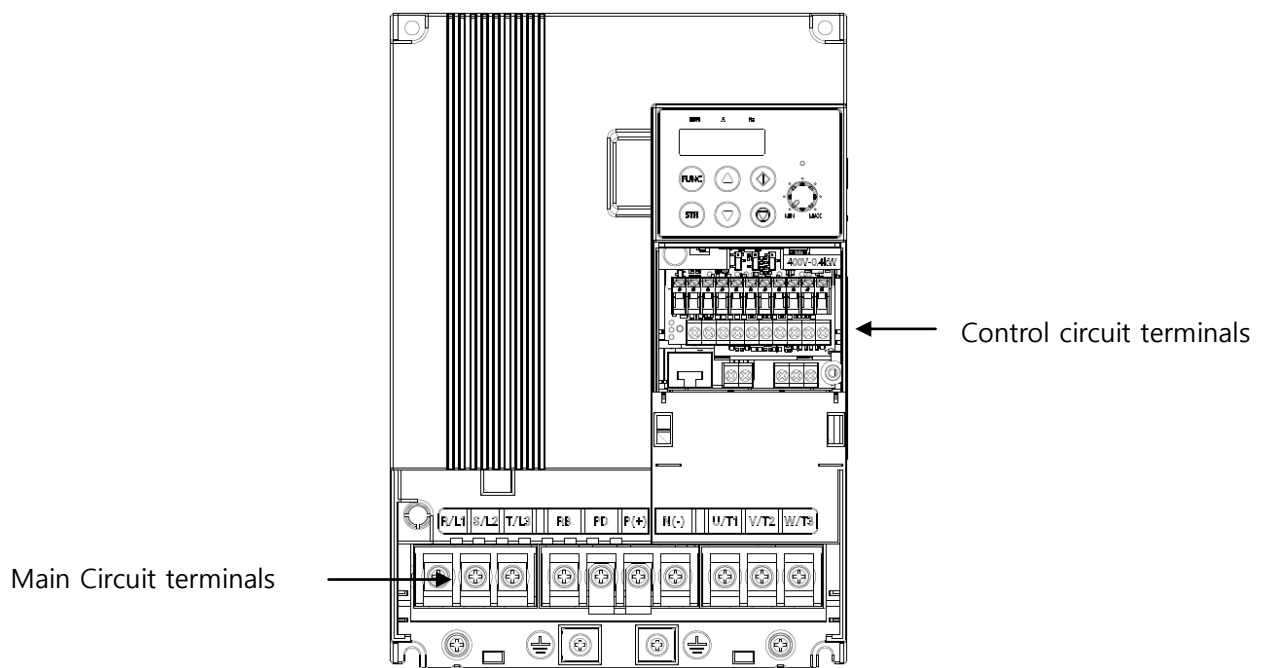

Figure 1-10 Front view without front cover

1.2.7 N750E -110LF/150LFP, 110HF/150HFP ~ 150HF/185HFP

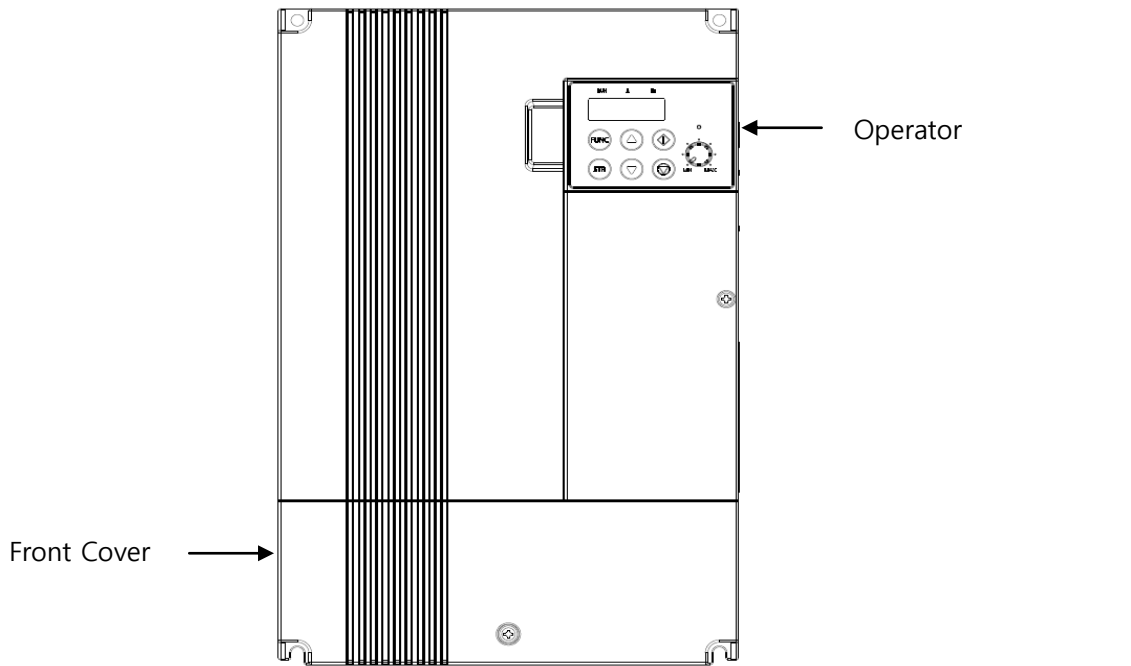

Figure 1-11 Front view with front cover

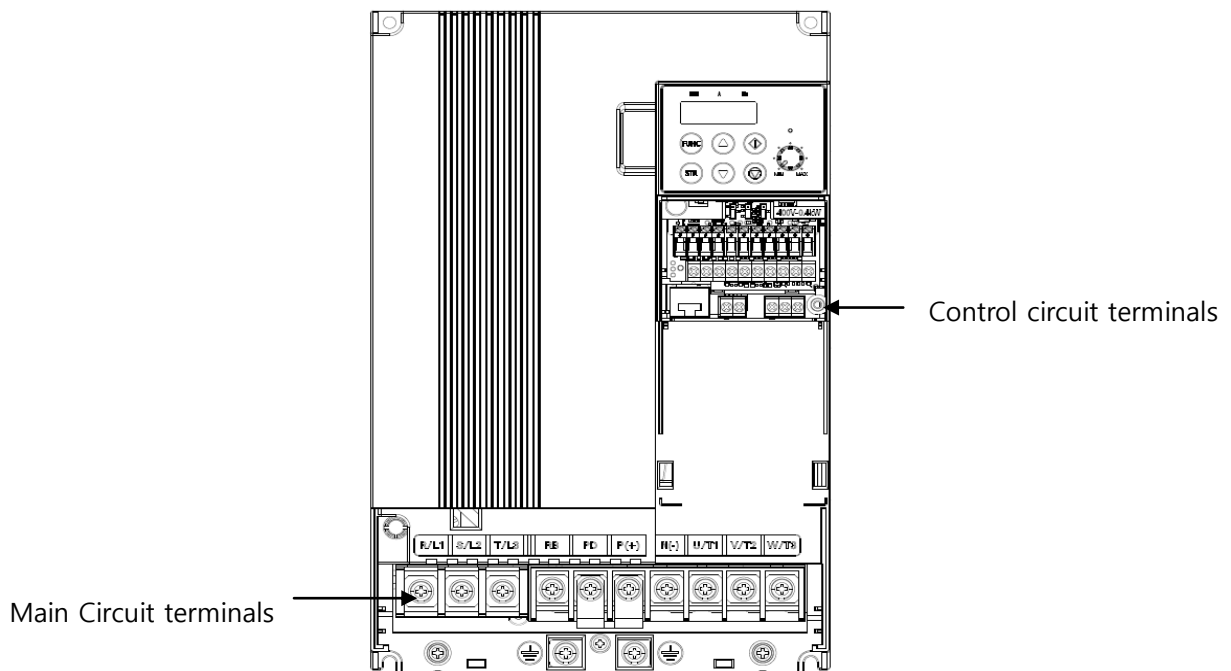

Figure 1-12 Front view without front cover

1.2.8 N750E-150LF/185LFP, 185HF/220HFP ~ 220HF/300HFP

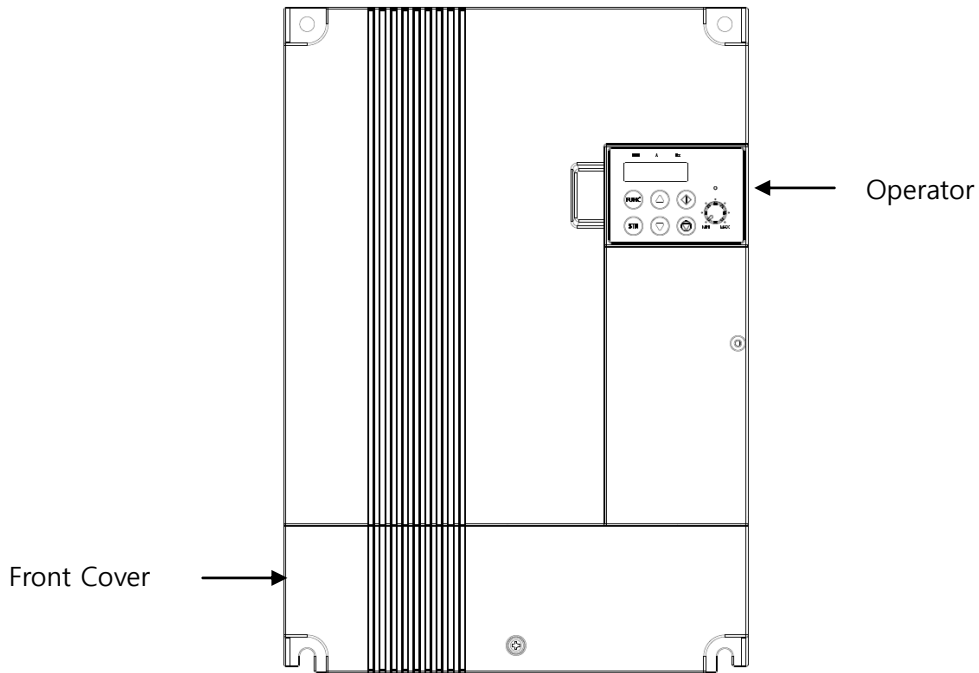

Figure 1-13 Front view with front cover

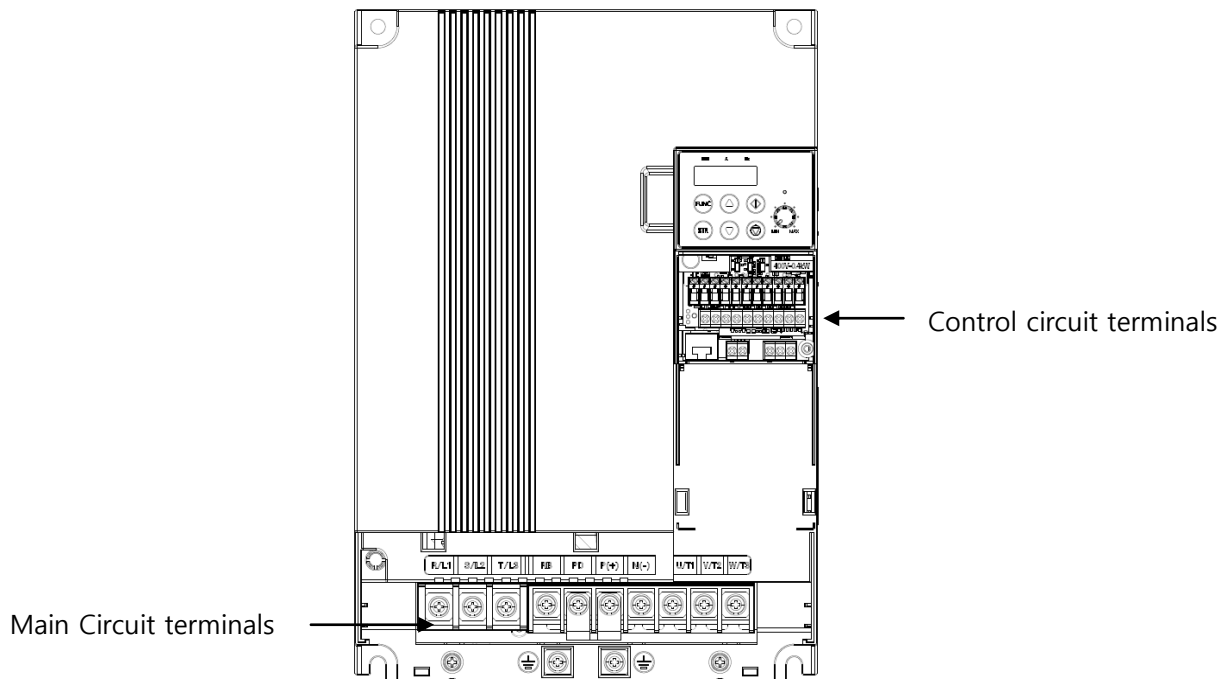

Figure 1-14 Front view without front cover

2. INSTALLATION AND WIRE

2.1 Installation

 **CAUTION**

- Be sure to install the unit on flame resistant material such as metal.
There is a fire hazard.
- Be sure not to place anything flammable such as corrosive gas, explosive gas, inflammable gas, grinding fluid mist, salt in the vicinity.
- Do not carry the unit by the top cover, but always by supporting the base of the unit
There is a possibility of an accident by falling down.
- Be sure not to let foreign matter enter such as cut wire refuse, spatter from welding, iron refuse, wire, dust, etc.
- Be sure to install the VFD in a place which can support the weight according to the specification in the manual.
- Do not install or run the damaged inverter.
There are concerns of an accident.
- Avoid high temperature, humidity, condensation dust corrosive gas, explosive gas, combustible gas and install the inverter with good ventilation without direct sunlight.
There is a fire hazard.
- To prevent injury, make sure to wear electric working gloves before working.

2.1.1 Precaution

(1) Caution in transport

- The inverter uses plastic parts. Care must be taken to avoid damage.
In particular, fasten it with designated parts to ensure that it is firmly secured to the wall or panel. Also, do not operate the inverter with damage and loss of parts.

(2) Install it on the non-flammable (metal, etc.) surface

- Inverter heat shield temperatures can be very high.
As there is a risk of fire, place it on a non-flammable vertical wall (metal, etc.).
Attention should also be made to the air gap surrounding the inverter.
Especially, when there is a heat source such as a braking resistor or reactor.
Keep sufficient space to prevent clogging of cooling ventilation by the up/down wiring.

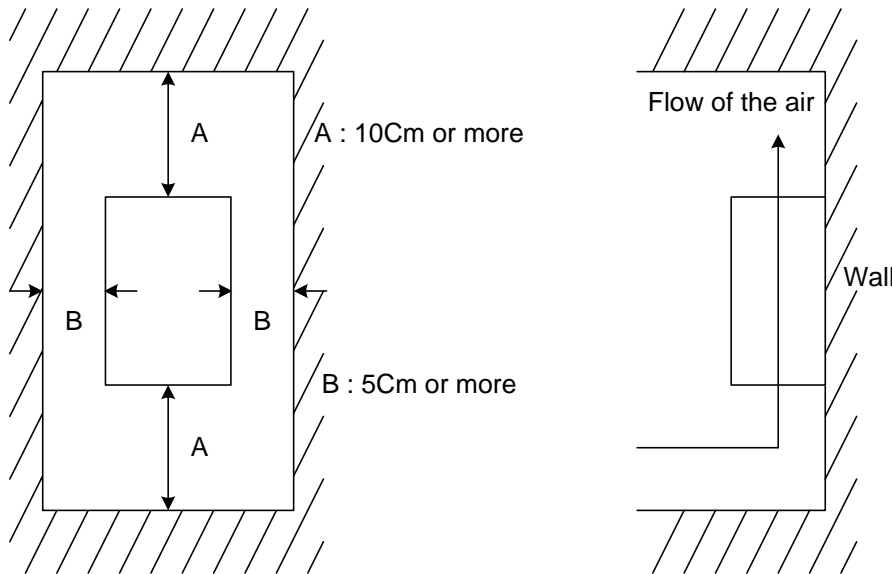

Figure 2-1 Air gap (Installation)

(3) Ambient temperature

- The ambient temperature surrounding the inverter should not exceed the allowable temperature range (HD: -10 to 50°C/ND: -10 to 40°C). Measure the ambient temperature about 5cm from the bottom center of the inverter body and make sure that it is within the allowable temperature range.
If the temperature exceeds the allowable temperature, component life will become shortened especially in the case of the bus capacitors.

(4) Humidity

- The humidity surrounding the inverter should be within the limit of the allowable percentage range (20% to 90% / RH).

Under no circumstances should the inverter be in an environment where there is the possibility of moisture entering the inverter.

Also avoid having the inverter mounted in a place that is exposed to the direct sunlight.

(5) Caution in the installation

- Please be install the inverter avoid dust, corrosive gases, explosive gases, combustible gases.

(6) Installation of inverter

- Mount the inverter in a vertical position using screws or bolts. The mounting surface should also be free from vibration and can easily hold the weight of the inverter.

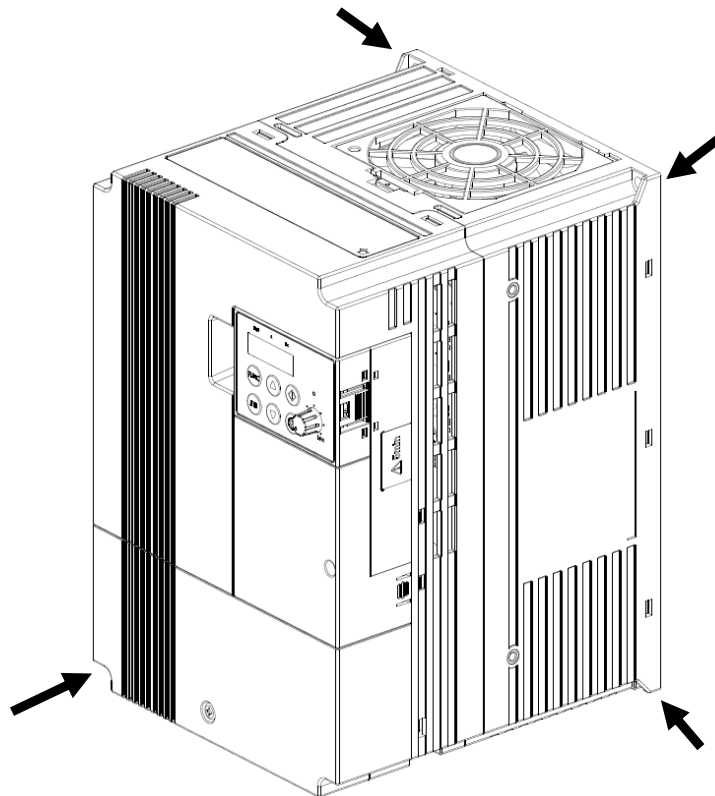

Figure 2-2 Mounting Position

(7) Ventilation in panel

- Install a ventilation fan when installing the inverter inside the panel. The position of the inverter cooling fan and air inlet is critical. If the position is incorrect, the air flow around the inverter will decrease and the temperature around the inverter will increase. Make sure that the ambient temperature is within the allowable range.

2.2 Wiring



DANGER

- Be sure to ground the unit.
There is a possibility of electric shock and fire.
- Wiring work should be carried out by qualified electricians
There is a possibility of electric shock and fire.
- Implement wiring after checking that the power supply is off.
There is a possibility of electric shock.
- After mounting the VFD, carry out wiring.
There is a possibility of electric shock.



CAUTION

- Make sure that the rated voltage and AC power voltage are same.
There are concerns of an accident and fire
- Be sure not to connect AC power supply to the output terminals (U, V, W).
There are concerns of an accident and fire
- Install the short circuit breaker on the input side.
There is a fire hazard.
- Use rated power lines, short circuit breakers and electronic contactors.
There is a fire hazard.
- Do not use the electromagnetic contactors on the primary side of the inverter as means of start/stop control.

2.2.1 0.4kW ~ 3.7kW Terminal connection diagram and description

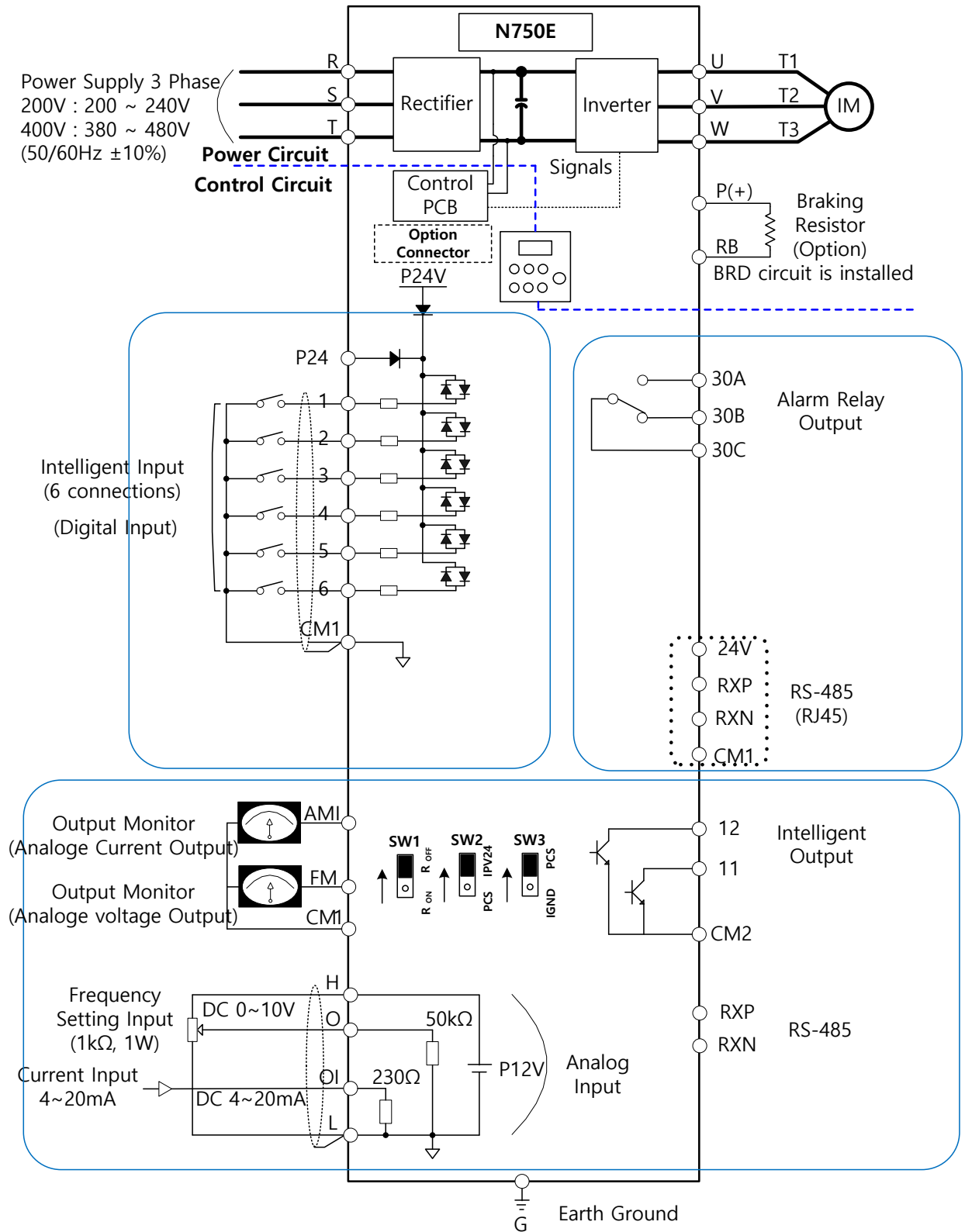

Figure 2-3 Terminal connection diagram (Sink type)

2.2.2 5.5kW ~ 22kW Terminal connection diagram and description

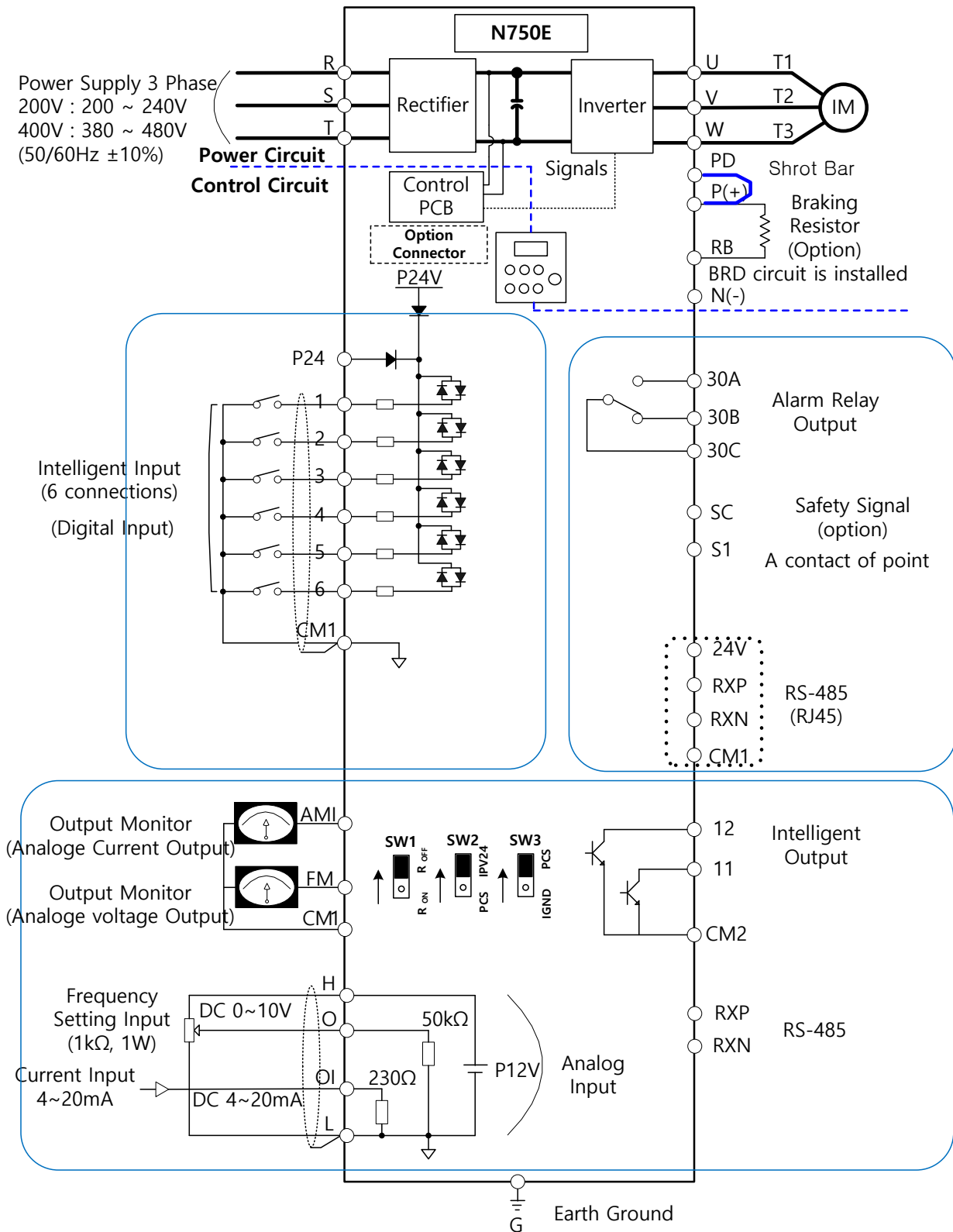

Figure 2-4 Terminal connection diagram (Sink type)

2.2.3 Main circuit terminal description

Table 2-1 Main circuit terminal description

Terminal	Terminal Name	Function
R,S,T (L1,L2,L3)	Main power input	AC input power supply
U,V,W (T1,T2,T3)	Inverter output	PWM output power for motor
P, RB (+,-)	External Braking Resistance Connection	Optional External Braking Resistor Connector.
G	Inverter ground	Ground Terminal

Table 2-2 Main circuit terminals view

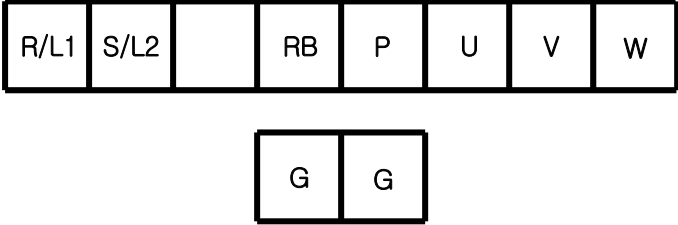
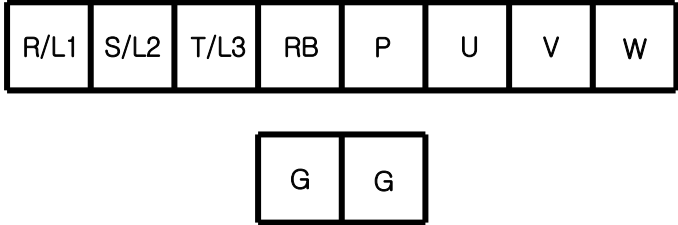
Main circuit terminals	Corresponding type	Screw size	width (mm)
	004SF 007SF	M3	6.02
	015SF 022SF	M3	8
	004LF 007LF 015LF	M3	6.02
	022LF 037LF 004HF 007HF 015HF 022HF 037HF	M4	8

Step1) Connecting 3-phase power to the input end of the inverter.

Connect 3-phase power to the inverter power input terminal R(L1), S(L2), T(L3) as table 2-2.

Step2) Connect the inverter to the three-phase motor.

Connect the inverter output stage U(T1), V(T2), W(T3) to the three-phase motor as table 2-2

Step3) The optional braking resistance is connected to the RB and P terminals as indicated.



Do not connect AC power to the output terminals (U,V,W). There is a fire hazard.

2.2.4 Main circuit terminal description

Table 2-1 Main circuit terminal description

Terminal	Terminal Name	Function
R,S,T (L1,L2,L3)	Main power input	AC input power supply
U,V,W (T1,T2,T3)	Inverter output	PWM output power for motor
PD,P (+1,+)	DC Reactor Connection	Remove the shorting bar between PD and P for connection to DC Reactor.
P, RB (+,-)	External Braking Resistance Connection	Optional External Braking Resistor Connector.
P, N	External Braking Unit Connection	Optional External Braking Unit Connector.
G	Inverter ground	Ground Terminal

Table 2-2 Main circuit terminals view

Main circuit terminals	Corresponding type	Screw size	width (mm)
	055LF/075LFP 075LF/110LFP 055HF/075HFP 075HF/110HFP	M4	10.3
	110LF/150LFP 110HF/150HFP 150HF/185HFP	M5	13
	150LF/185LFP 185HF/220HFP 220HF/300HFP	M5	13

- Step1) Connecting 3-phase power to the input end of the inverter.
Connect 3-phase power to the inverter power input terminal R(L1), S(L2), T(L3) as table 2-2.
- Step2) Connect the inverter to the three-phase motor.
Connect the inverter output stage U(T1), V(T2), W(T3) to the three-phase motor as table 2-2
- Step3) The optional direct current reactors are hardwired to the P and PD terminals as shown.
However, remove the shorting bar when connecting the DC reactor.

 Do not connect AC power to the output terminals (U,V,W). There is a fire hazard.

2.2.5 Main circuit terminal wiring

(1) Warning on wiring

When carrying out work on the inverter wiring make sure to wait for at least ten minutes before you remove the cover. Be sure to verify that the charge lamp is not illuminated.

A final check should always be made with a voltage meter.

After removing the power supply, there is a time delay before the capacitors will dissipate their charge.

1) Main power terminals: R(L1), S(L2), T(L3)

- Connect the main power terminals (R(L1), S(L2) and T(L3)) to the power supply through an electromagnetic contactor or an earth-leakage breaker. Use a high harmonic sensitivity current value as the short circuit breaker may malfunction due to harmonic effects. Install an electronic contactor to turn off the inverter power to prevent failure or accident when inverter's protection function is activated.
- LF/HF unit is for a three-phase power supply. Be sure not to power a three-phase only inverter with single phase power.
- Do not stop operation by switching off the electromagnetic contactors on the primary or secondary sides of the inverter.
- The inverter enters into the following condition at the occurrence of open phase if it is selected open phase protection is valid: R phase, S phase or T phase, open phase condition:
It becomes single-phase operation condition. Trip operation, such as a deficiency voltage or over current, may occur.
- A converter module may be damaged as a result of the following conditions. Use caution when,
 - Unbalanced power supply voltage more than 3%
 - Power supply capacity is more than 10 times of the capacity of inverter
 - A drastic change in the power supply
- Turning on/off the power supply more than three times in one minute. Could be damaged.

2) Inverter output terminals: U(T1), V(T2), W(T3)

- Make sure to use a heavier gauge wire when you have long motor leads. This will help to reduce the voltage drop.
- Do not install power factor correction capacitors or a surge absorber to the output of the inverter. Inverter will trip or sustain damage to the output transistors.
- In the case of the cable length being more than 20 meters, it is possible that a surge voltage will be generated and damage to the motor is caused by the floating capacity or the inductance in the wire. When an EMC filter is to be installed, please contact to us.
- In the case of two or more motors, install a thermal relay to each motor.
- Make the RC value of the thermal relay the value of 1.1 times of motor rated electric current

3) Direct current reactor (DCL) connection terminals (PD, P)

- Only 5.5kw to 22kw inverters are available.
- These are the terminals to connect the current reactor DCL (optional) to help improve the power factor. The short bar is connected to the terminals when shipped from the factory, if you are to connect a DCL you will need to disconnect the short bar first.
- The cable length should be less than 5 meters.

4) External braking resistor connection terminals (P, RB)

- The regenerative braking circuit (BRD) is built-in as standard.
- When braking is required, install an external braking resistor to these terminals.
- The cable length should be less than 16 feet, and twist the two connecting wires to reduce inductance.
- Do not connect any other device other than the external braking resistor to these terminals. When installing an external braking resistor make sure that the resistance is correctly rated to limit the current drawn through the BRD.

5) Earth ground (G)

- Make sure that you securely ground the inverter and motor for prevention of electric shock. The inverter and motor must be connected to an appropriate safety earth ground and follow all local electrical codes.
- In case connecting 2 or more inverters, use caution not to use a loop which can cause some malfunction of the inverter.

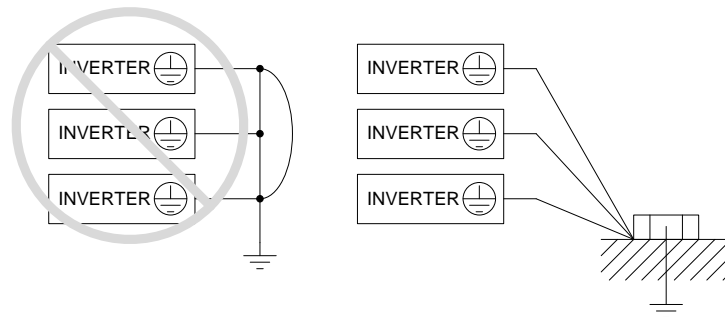

Figure 2-4 Earth Ground (G)

2.2.6 Control circuit terminal description

Table 2-3 Control Circuit Terminal Description

Signal	Terminal	Terminal Name	Function
Input signal	P24	Power terminal for input signal	24VDC \pm 15%, 100mA
	6	Intelligent input terminal (C01~C06)	Contact input: Close: ON (Operating) Open: OFF (Stop) Minimum ON TIME:12ms
	5	Forward run command (FW), Reverse run command (RV), Multi-speed commands1-4(CF1-4), 2-stage accel/decel (2CH), Reset (RS), Free run stop (FRS), External trip (EXT), Terminal software lock (SFT), Current input selection (AT), Jogging operation (JG), Unattended start protection (USP),	
	4	3 wires input (STA,STP,F/R), Up/Down (Up, Down), Local keypad operation(O/R), Local terminal input operation(T/R),	
	3	PID integral reset (PIDIR), PID disable (PIDD), Add A11 to setting frequency(F.O),Cancel add A11(R.O), External trip2(EXT2),External trip3(EXT3),	
	2	External trip4(EXT4), External trip5(EXT5)	
	1	External trip6(EXT6), Up/Down Value Clear	
	CM1	Common terminal for input or monitors signal	
Monitor signal	FM	Analog Monitor (Frequency, Current, Voltage, Power)	0~10Vdc, 1mA
	AMI	Analog Monitor (Frequency, Current, Voltage, Power)	4~20mA, 250 Ω
Frequency command signal	H	Frequency power	10.5VDC
	O	Frequency command power terminal (voltage)	0-10VDC, Input impedance: 50k Ω
	OI	Frequency command terminal (current)	4-20mA, Input impedance: 230 Ω
	L	Analog power common	-
Intelligent relay output signal	30A	Relay output terminal (C13)	AC 250V 2.5A (Resistor load) 0.2A (Inductor load) DC 30V 3.0A (Resistor load) 0.7A (Induction load)
	30B	Run status signal (RUN), Frequency arrival signal (FA1), Set frequency arrival signal (FA2), Overload advance notice signal (OL), PID error deviation signal (OD),Alarm signal (AL), MO (Modbus communication),SOL (System Overload), SUL (System Underload),	
	30C	SOL/SUL(System Overload/Underload detection), AI_LOSS(Analog Input loss detection), KEY_LOSS(keypad loss detection), BRK(Control external braking)	

Signal	Terminal	Terminal Name	Function
Intelligent output signal	11	Open collector output (C14~C15)	24VDC, 50mA max
	12	Run status signal (RUN), Frequency arrival signal (FA1), Set frequency arrival signal (FA2), Overload advance notice signal (OL), PID error deviation signal (OD), Alarm signal (AL), MO (Modbus communication), SOL (System Overload), SUL (System Underload), SOL/SUL(System Overload/Underload detection) AI_LOSS(Analog Input loss detection), KEY_LOSS(keypad loss detection), BRK(Control external braking)	
	CM2	Common terminal for output	
1 st communication (RJ-45)	RXP	RJ-45 connector no. 3	RS-485 communication terminal
	RXN	RJ-45 connector no. 6	
Safety input signal	SC	Common terminal for safety input	Intelligent input (Only 5.5kW~22kW Inverter are Available)
	S1	Safety A point input	
2 nd communication (speed set b31)	RXP	RS-485 (+)	2 nd RS-485 communication terminal
	RXN	RS-485 (-)	

2.2.7 Control circuit terminal wiring

(1) Wiring of control circuit terminal

The control circuit terminal of N750E is as below,

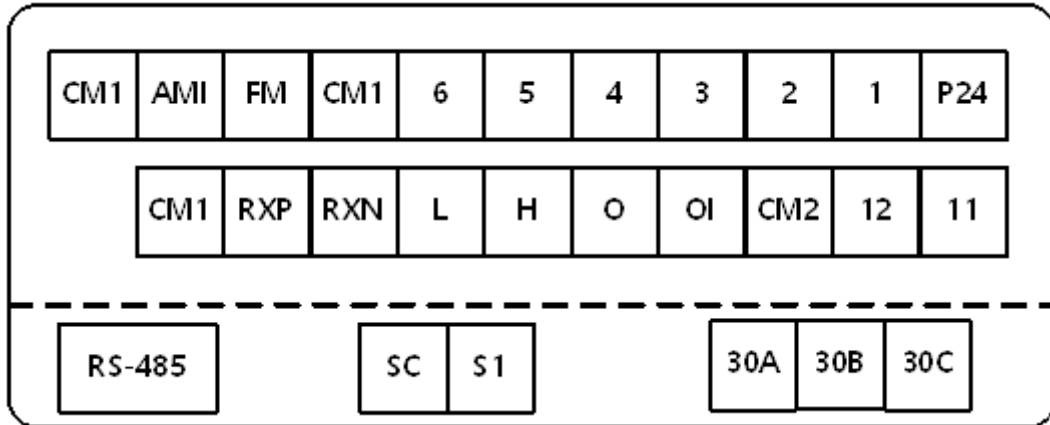

Figure 2-5 Control circuit terminal^{note1}

Note 1) The SC and C1 terminals only provide Inverter over 5.5 kW

(2) Example of control circuit wiring

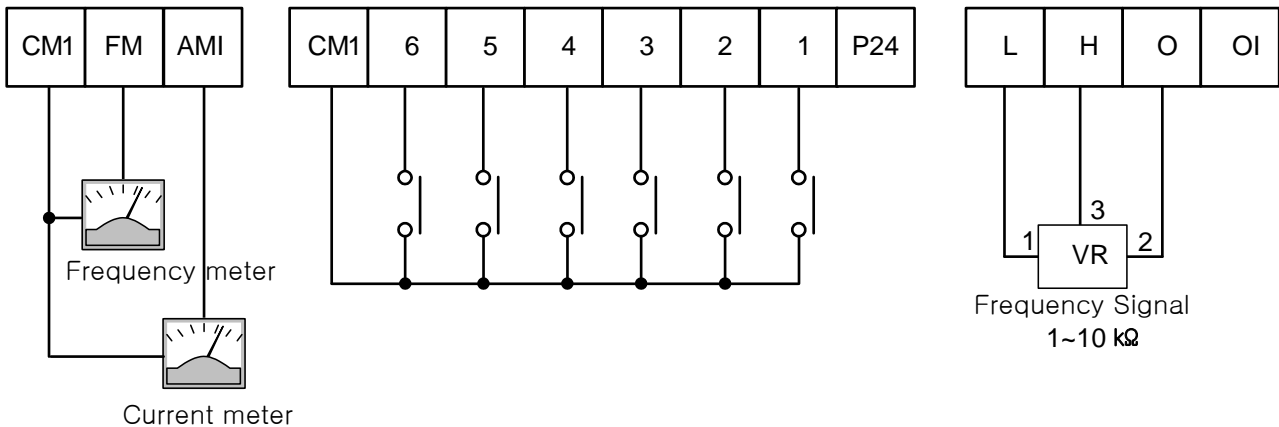

Figure 2-6 Example of control circuit wiring

(3) Precaution of wiring

- 1) Control terminals are insulated to its power lines (R, S, T, U, V, W, PD, N, RB).
Do not connect those terminals to power lines or ground.
- 2) Use twisted screened cable, for the input and output wires of the control circuit terminals. Connect the screened cable to the common terminal.
- 3) Limit the connection wires to 20 meters.
- 4) Separate the control circuit wiring from the main power and relay control wiring.
If it is inevitable to cross, make it orthogonal. There is a concern of inverter malfunction.

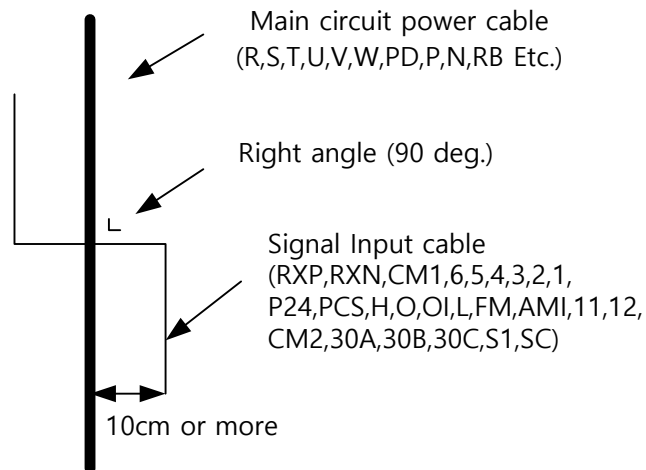

Figure 2-7 Separate of main circuit and control circuit wire

- 5) When using relays for the FW terminal or an intelligent input terminal use a control relay that is designed to work with 24Vdc.
- 6) When a relay is used as an intelligent output, connect a diode for surge protection parallel to the relay coil.
- 7) Do not short the analog voltage terminals H and L or the internal power terminals P24 and all CM1's. Otherwise there is risk of Inverter damage.

(4) Selection the switches

1) RS-485-line termination resistor

Line termination resistor is used to decrease delay of distortion and attenuation at the long distance. It inserts one on the line termination. line termination resistor of inverter is build-in and it can be selected by SW1 switch.

<Line termination resistor switch selection >

SW1: Default value is OFF

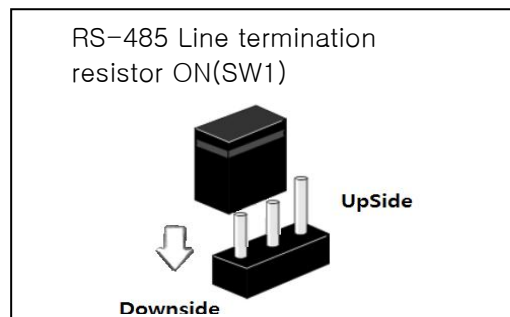
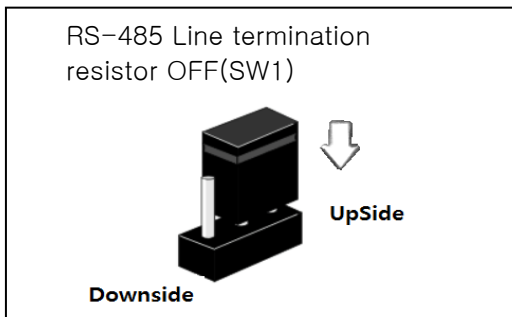
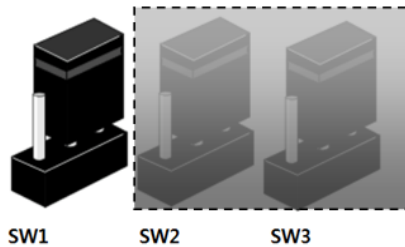

2) Connections between Relay output and PLC

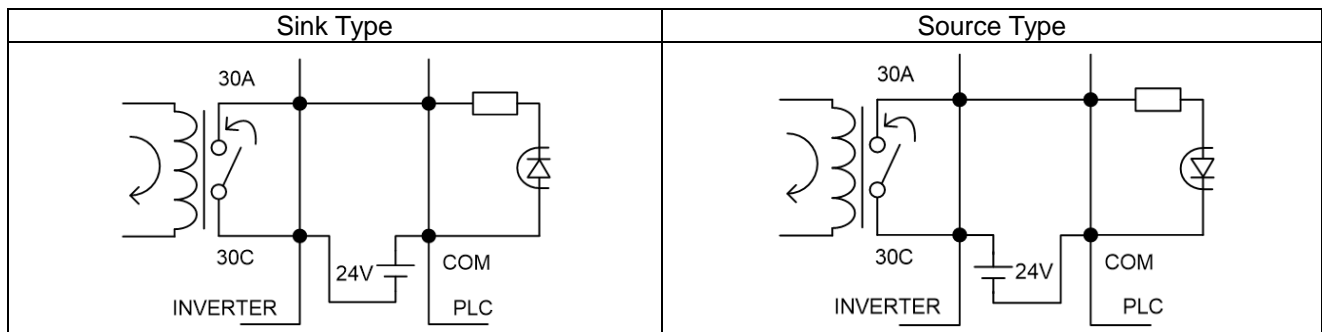
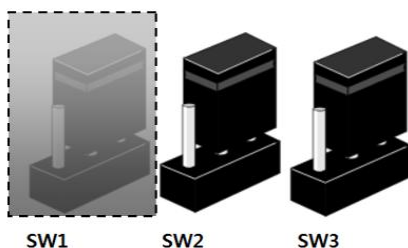

Figure 2-8 Connections between Relay and PLC

3) Connection between Input terminal and PLC: Factory setting is Sink type mode

- SW2: Power Source switch for Internal 24V (factory setting) or external PCS input
- SW3: Select switch for Sink type mode (factory setting) and Source type mode



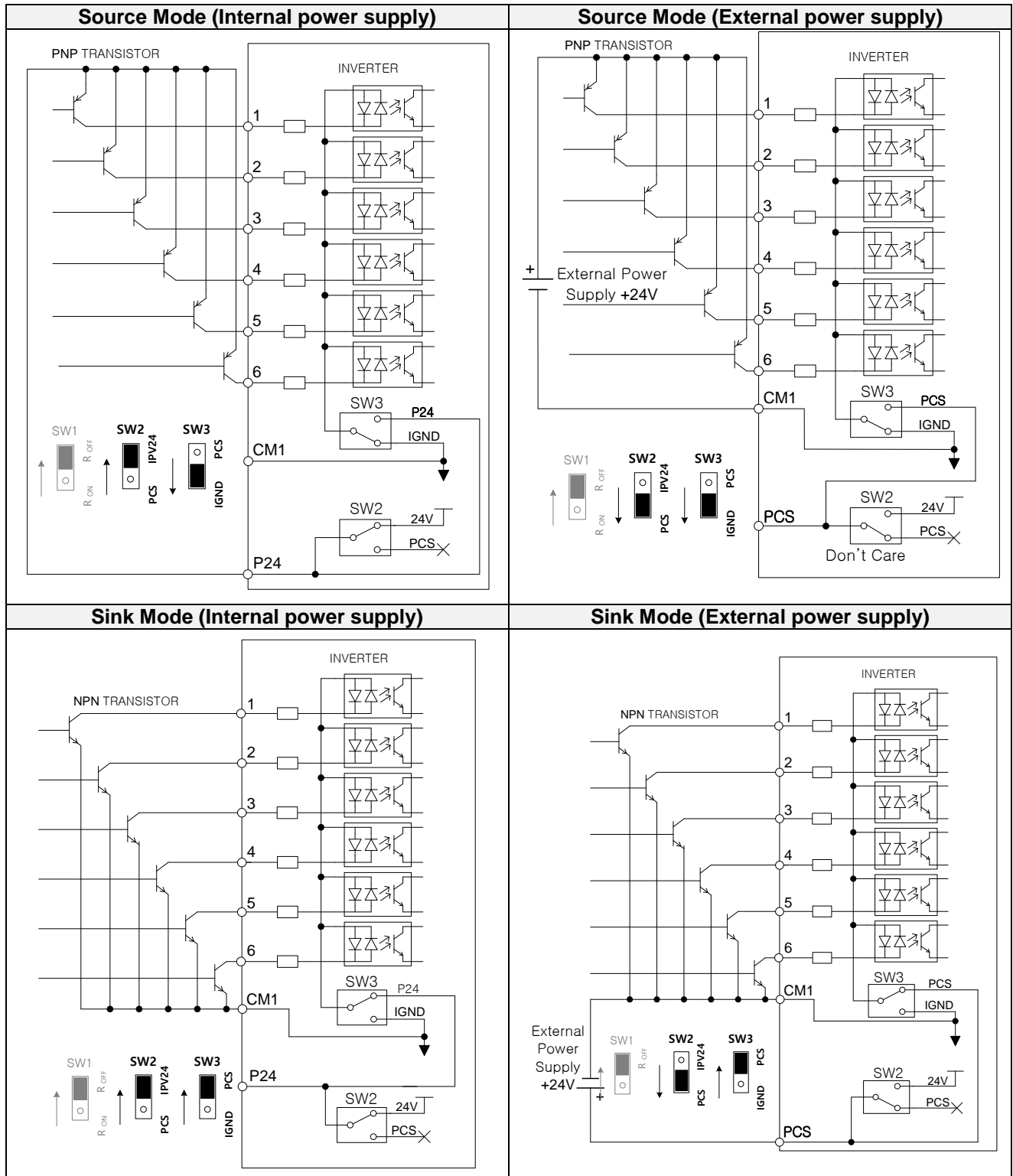
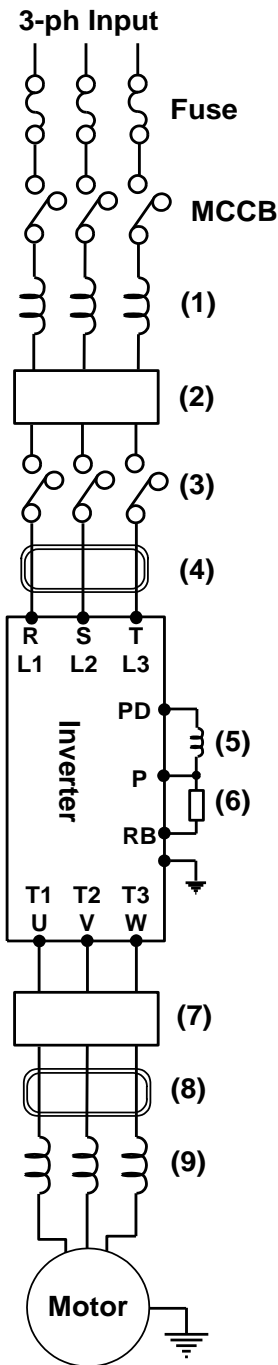

Figure 2-9 Input Terminal and PLC Connection Diagram

2.2.8 Accessory wiring



Note1: The applicable equipment is for HYUNDAI standard four pole squirrel cage motor.

Note2: Be sure to consider the capacity of the circuit breaker to be used.

Note3: Be sure to use larger wire for power lines if the distance exceeds 20m.

Note4: Be sure to use MCCB for the safety.

Note5: Do not operate the electronic contactor when the inverter is running.

Note6: Use 0.75mm² for AL relay and RN relay. Separate by the sum (wiring distance from inverter to power supply, from inverter to motor) for the sensitive current of leakage breaker (MCCB).

Note7: When using CV line and wiring by rigid metal conduit, leak flows

Wiring distance	Sensitive current(mA)
100m and less	50mA
300m and less	100mA

Note8: IV line is high dielectric constant that is why the current will be increased 8 times. Therefore, use the sensitive current 8 times as large as that of the left list. And if the distance of wire is over 100m, use CV line.

Note9: Do not stop operation by switching off the electromagnetic contactors. If you need to use electromagnetic contactors for predation because of bypass operation, be sure the protective circuit must be configured so that it cannot be switched on or off during inverter operation.

Figure 2-10
Example of accessories connection

Table 2-4 Optional accessories for improved performance

Name		Function
(1)	Input AC Reactor	Recommended to use when the unbalance voltage rate is 3% or more and power supply is 500 kVA or more, and there is a rapid change in the power supply. It also reduces harmonics and improves the power factor.
(2)	Noise filter for Inverter	Reduces common noise generated between the power supply and the ground, as well as normal noise. Put it in the primary side of inverter.
(3)	Radio Noise Filter (zero-phase reactor)	Helps to reduce noise on a peripheral radio when an inverter is running.
(4)	Input Radio Noise Filter	Reduces radiation noise emitted from wire at the input.
(5)	DC Reactor ^{note1}	Helps to improve power factor for the inverter.
(6)	Breaking Resistor/ Regenerative Breaking Unit	Used for applications that need to increase the brake torque of the inverter or to frequently start/stop and to run high inertia load.
(7)	Output Noise Filter	Reduces noise emitted from the inverter motor leads. This helps to minimize interference with sensitive equipment (i.e.: sensors or weight scale).
(8)	Radio Noise Filter (Zero-phase reactor)	Reduces noise generated at the output of the inverter. (It is possible to use for both input and output.)
(9)	Output alternation reactor Reducing vibration, thermal Relay, preventing Misapplication	Running motors with the inverter generates vibration greater than that with commercial power supply. This part installed between the inverter and motor reduces torque ripple. When the cable length between the inverter and motor is long (10m or more), a countermeasure for a malfunction of the thermal relay by harmonic due to switching on inverter is taken by inserting reactor. There is the way to use current sensor instead of thermal relay.
	LCR filter	Sine-wave filter for output

Note 1) Only inverters greater than 5.5kw are available.

2.2.9 Torque and wire specification

Table 2-5 Applicable tools for N750E (Heavy duty) ^{note2}

Class	Motor Output (kW)	Inverter model (N750E)	Power lines ^{note1} R,S,T, U,V,W,PD,P	External resistor between P and RB	Screw size of Terminal	Torque (N•m)	Applicable Tools		
							Leak breaker (MCCB)		Electro-magnetic Controller (MC)
200V Class	0.4	004SF	2.1	2.1	M3	0.5	UAB-30C	5A	UMC12
	0.4	004LF	2.1	2.1	M3	0.5	UAB-30C	5A	UMC12
	0.75	007SF	2.1	2.1	M3	0.5	UAB-30C	10A	UMC12
	0.75	007LF	2.1	2.1	M3	0.5	UAB-30C	10A	UMC12
	1.5	015SF	3.3	3.3	M4	1.2	UAB-30C	15A	UMC12
	1.5	015LF	2.1	2.1	M3	0.5	UAB-30C	15A	UMC12
	2.2	022SF	5.3	5.3	M4	1.2	UAB-30C	20A	UMC25
	2.2	022LF	3.3	3.3	M4	1.2	UAB-30C	20A	UMC25
	3.7	037LF	5.3	5.3	M4	1.2	UAB-30C	30A	UMC25
	5.5	055LF/075LFP	More than 6	6	M4	1.2	UCB100R	50A	HiMC32
	7.5	075LF/110LFP	More than 10	6	M4	1.2	UCB100R	50A	HiMC32
	11	110LF/150LFP	More than 16	6	M5	3.0	UCB100R	75A	HiMC50
	15	150LF/185LFP	More than 25	16	M5	3.0	UCB100R	100A	HiMC65
400V Class	0.4	004HF	2.1	2.1	M4	1.2	UAB-30C	5A	UMC12
	0.75	007HF	2.1	2.1	M4	1.2	UAB-30C	5A	UMC12
	1.5	015HF	2.1	2.1	M4	1.2	UAB-30C	10A	UMC12
	2.2	022HF	2.1	2.1	M4	1.2	UAB-30C	10A	UMC12
	3.7	037HF	3.3	3.3	M4	1.2	UAB-30C	15A	UMC25
	5.5	055HF/075HFP	More than 4	4	M4	1.2	UAB30C	30A	HiMC18
	7.5	075HF/110HFP	More than 4	4	M4	1.2	UAB30C	30A	HiMC18
	11	110HF/150HFP	More than 6	6	M4	1.2	UCB100R	50A	HiMC32
	15	150HF/185HFP	More than 10	10	M5	3.0	UCB100R	50A	HiMC40
	18.5	185HF/220HFP	More than 16	10	M5	3.0	UCB100R	75A	HiMC40
	22	220HF/300HFP	More than 25	10	M5	3.0	UCB100R	75A	HiMC50

Note 1) Use a 600V, 75°C copper wire for wires.

Note 2) 3.7 kW or less inverter are based on (Heavy duty).

Table 2-6 Applicable tools for N750E P-TYPE (Normal duty)

Class	Motor Output (kW)	Inverter model (N750E)	Power lines ^{note1} R,S,T, U,V,W,PD,P	External resistor between P and RB	Screw size of Terminal	Torque (N·m)	Applicable Tools		
							Leak breaker (MCCB)		Leak breaker (MCCB)
200V Class	7.5	055LF/075LFP	More than 10	6	M4	1.2	UCB100R	50A	HiMC32
	11	075LF/110LFP	More than 16	6	M5	3.0	UCB100R	75A	HiMC50
	15	110LF/150LFP	More than 25	16	M5	3.0	UCB100R	100A	HiMC65
	18.5	150LF/185LFP	More than 30	16	M6	4.5	UCB250S	150A	HiMC80
400V Class	7.5	055HF/075HFP	More than 4	4	M4	1.2	UAB30C	30A	HiMC18
	11	075HF/110HFP	More than 6	6	M4	1.2	UCB100R	50A	HiMC32
	15	110HF/150HFP	More than 10	10	M5	3.0	UCB100R	50A	HiMC40
	18.5	150HF/185HFP	More than 16	10	M5	3.0	UCB100R	75A	HiMC40
	22	185HF/220HFP	More than 25	10	M5	3.0	UCB100R	75A	HiMC50
	30	220HF/300HFP	More than 25	-	M6	4.5	UCB100R	100A	HiMC65

Note 1) Use a 600V, 75°C copper wire for wires.

3. SPECIFICATION

3.1 Specification

3.1.1 200V Class specification

Inverter model			004SF	007SF	015SF	022SF
Applicable motor (4P, kW) ^(Note1)	HD		0.4	0.75	1.5	2.2
	Rated capacity (kVA)	HD	200V	1.0	1.7	2.6
240V			1.2	2.0	3.1	4.6
Rated input voltage		Three Phase 200 ~ 240 V +/- 10 %, 50/60 Hz +/- 5%				
Rated output voltage ^(Note2)		Three Phase 200 ~ 240 V (Corresponding to Input Voltage)				
Rated output current(A) ^(Note3)	HD		2.8(3.2)	4.8(5)	7.5(8.5)	11(12.5)
Weight (Kg)			0.76	0.76	0.96	0.96
Protection Design		IP20				

Inverter model			004LF	007LF	015LF	022LF	037LF
Applicable motor (4P, kW) ^(Note1)	HD		0.4	0.75	1.5	2.2	3.7
	Rated capacity (kVA)	HD	200V	1.0	1.7	2.6	3.8
240V			1.2	2.0	3.1	4.6	7.1
Rated input voltage		Three Phase 200 ~ 240 V +/- 10 %, 50/60 Hz +/- 5%					
Rated output voltage ^(Note2)		Three Phase 200 ~ 240 V (Corresponding to Input Voltage)					
Rated output current(A) ^(Note3)	HD		2.8(3.2)	4.8(5)	7.5(8.5)	11(12.5)	17(19.5)
Weight (Kg)			0.76	0.76	0.76	0.96	1.34
Protection Design		IP20					

Inverter model			055LF/ 075LFP	075LF/ 110LFP	110LF/ 150LFP	150LF/ 185LFP
Applicable motor (4P, kW) ^(Note1)	HD		5.5	7.5	11	15
	ND		7.5	11	15	18.5
Rated capacity (kVA)	HD	200V	8.7	11.4	16.3	22.2
		240V	10.4	13.7	19.5	26.6
	ND	200V	10.4	13.7	19.5	26.6
		240V	12.5	16.6	23.3	30.3
Rated input voltage		Three Phase 200 ~ 240 V +/- 10 %, 50/60 Hz +/- 5%				
Rated output voltage ^(Note2)		Three Phase 200 ~ 240 V (Corresponding to Input Voltage)				
Rated output current(A)	HD		25	33	47	64
	ND		30	40	56	73
Weight (Kg)			3.2	3.2	6.6	7.2
Protection Design		IP20				

3.1.2 400V Class specification

Inverter model		004HF	007HF	015HF	022HF	037HF	
Applicable motor (4P, kW) ^(Note1)	HD	0.4	0.75	1.5	2.2	3.7	
Rated capacity (kVA)	HD	380V	1.0	1.8	2.8	3.6	5.9
		480V	1.2	2.2	3.5	4.6	7.5
Rated input voltage		Three Phase 380 ~ 480 V +/- 10 %, 50/60 Hz +/- 5%					
Rated output voltage ^(Note2)		Three Phase 380 ~ 480 V (Corresponding to Input Voltage)					
Rated output current(A) ^(Note3)	HD	1.5(1.8)	2.7(3.4)	4.2(4.8)	5.5(7.2)	9.0(10.5)	
Weight (Kg)		0.76	0.76	0.96	0.96	1.34	
Protection Design		IP20					

Inverter model		055HF/ 075HFP	075HF/ 110HFP	110HF/ 150HFP	150HF/ 185HFP	185HF/ 220HFP	220HF/ 300HFP	
Applicable motor (4P, kW) ^(Note1)	HD	5.5	7.5	11	15	18.5	22	
	ND	7.5	11	15	18.5	22	30	
Rated capacity (kVA)	HD	380V	9.7	11.8	15.8	21.1	25.7	29.6
		480V	12.3	15.0	20.0	26.6	32.4	37.4
	ND	380V	11.5	15.1	20.4	25	29.0	38.2
		480V	14.5	19.1	25.8	31.6	36.6	48.2
Rated input voltage		Three Phase 380 ~ 480 V +/- 10 %, 50/60 Hz +/- 5%						
Rated output voltage ^(Note2)		Three Phase 380 ~ 480 V (Corresponding to Input Voltage)						
Rated output current(A)	HD	14.8	18	24	32	39	45	
	ND	17.5	23	31	38	44	58	
Weight (Kg)		3.2	3.2	6.6	6.6	7.2	7.2	
Protection Design		IP20						

Note 1: The applicable motor refers to HYUNDAI standard 3-phase motor (4-pole).

To use other motors, care must be taken to prevent the rated motor current (50/60Hz) from exceeding the rated output current of the inverter.

Note 2: The output voltage decreases as the main supply voltage decreases (except for use of the AVR function).

In any case, the output voltage cannot exceed the input power supply voltage.

Note 3: Ambient temperature is less or than 40°C, you can be used as a rated current within ().

3.1.3 Performance specification

Features		Performance specification
Control method ^(Note4)		Space vector PWM
Output frequency range ^(Note5)		0.01 ~ 400Hz (Sensorless Vector Control: 0.5 ~ 300Hz)
Frequency accuracy ^(Note6)		Digital command $\pm 0.01\%$ of Max Frequency / Analog Frequency $\pm 0.1\%$
Frequency resolution		Digital setting: 0.01Hz (Under 100Hz), 0.1Hz (Over 100Hz) Analog setting: Max. frequency 500(DC5V), Max. setting frequency 1000 (DC 0 ~ 10V, 4~20mA)
Voltage/frequency characteristic		Base Frequency 0-400Hz setting
Overload current rate		Heavy Duty (150%, 60sec), Normal Duty (120%, 60sec)
Acceleration/deceleration		0.0~6,000 sec (Linear, S curve, U curve) Second acc/dcc can be set
DC injection braking		Operation level and time can be set when above the minimum frequency and below the braking set frequency
Input Signal	Frequency	Operator external signal Set by Keypad (Potentiometer or Arrow Keys) Variable resistance 1W, 1k Ω ~10k Ω DC 0 ~ 10V (Input impedance 10K Ω), DC 4 ~ 20mA (Input impedance 200 Ω)
	Run/Stop	Operator external signal Run/Stop key Forward run/stop Reverse operation/stop is possible for terminal assignment (select 1a, 1b)
	Intelligent input terminal	FW (Forward Run), RV (Reverse Run), CF1~4(Multi-speed Inputs 1~4), RS(Reset), AT (Analog input current/voltage selection signal), USP (Unattended Start Protection), EXT (External trip), FRS (Free-Run Stop), JG(Jogging), SFT (software lock), 2CH (2nd Acceleration / Deceleration), STA, STP, F/R, UP, DOWN(Up/down), UP/DOWN initial value clear O/R (Local Keypad Operation), T/R (Local Terminal Input Operation), PIDIR (PID Integral Reset), PIDD (PID Disabled), F.O (Add A11 to setting frequency), R.O (Cancel add A11), EXT2 (External trip2), EXT3 (External trip3), EXT4 (External trip4), EXT5 (External trip5) EXT6 (External trip6), Up/Down Value Clear
Output Signal	Intelligent output terminal (11-CM2, 12-CM2)	RUN (Run Status Signal), FA1 (Frequency Arrival Signal 1), FA2 (Frequency Arrival Signal 2), OL (Overload Alarm), OD (PID Error Deviation Signal), AL (Alarm signal), MO (Modbus communication),SOL (System Overload),SUL (System Underload), SOL/SUL(System Overload/Underload detection),AI_LOSS(Analog Input loss detection),KEY_LOSS(keypad loss detection),BRK(Control external braking)
	Alarm relay output terminal	
	FM output	Analog output meter (DC0~10V full scale. Max · 1mA) Output Frequency, Output Current, Output Voltage, Output Power, Output Torque, Operation by Communication, DC voltage
	AMI output	Analog output meter (4~20mA full scale. Max · 250 Ω) Output Frequency, Output Current, Output Voltage, Output Power, Output Torque, Operation by Communication, DC voltage

Features		Performance specification
Application specification functions		Auto tuning, AVR function, V/F characteristic selection, Curved acceleration/deceleration, Upper and lower limiters, 16-stage speed profile, Fine adjustment of start frequency, Carrier frequency change (0.5~16kHz), PID, Frequency jump, Gain and Bias setting, Jogging, Electronic thermal level adjustment, Retry function, Automatic torque boost, Trip history monitor, Software lock, S-curved acc/dcc, Frequency conversion display, UPS, IOLT protection, Flying start, BRD
Protection functions		Over current, Over voltage, Communication error, Under voltage, Output short circuit detection, UPS error, EEPROM error, External trip1~6, Ground fault, Over temperature, Input phase loss, Overload, Inverter overload, Braking resistor overload, CPU error, Safety function, HW trip 1~2, Option trip 1~2, OVS fail, Fan fault
E n v i r o m e n t	Ambient temperature	-10~50℃ (ND: 40℃)
	Storage temperature	-20~60℃
	Ambient humidity	Below 90%RH (Installed with no dew condensation)
	Vibration	5.9m/s ² (0.6G). 10~55Hz
	Location	Under 1000m above sea level, indoors (Installed away from corrosive gasses dust)
Option		Noise filter, DC reactor, AC reactor Remote operator, cable for remote operator, Braking resistor ^(Note7)

(Note4) Control method setting A31 to 2 (sensorless vector control) Selected, set carrier frequency more than 2.1kHz.

Sensorless vector performance will be reduced when using a motor less than half of the rated capacity of the inverter.

Multiple motors cannot be driven by sensorless vector control.

(Note5) To operate the motor over 50/60Hz, consult the motor manufacturer about the maximum allowable rotation speed.

(Note6) For motor stabilization control, the output frequency can exceed the maximum frequency set in [A04] up to 1.5 Hz.

(Note7) The inverter also has a regenerative braking circuit built in. However, if a large regenerative torque is required, use the optional braking resistance.

3.1.4 Braking resistor specification

- Resistor values in below table are calculated on the basis of 150% rated braking torque, 5% ED^(Note1)
- Wattage rating of resistor should be doubled for 10% ED.

Recommended DB Resistors for the Rated Inverter Capacity (5% ED^{(Note1),(Note2)})

Inverter capacity	Ohm [Ω]	Wattage [W] ^(Note2)
004SF	50	300
007SF	50	300
015SF	50	300
022SF	50	300
004LF	50	300
007LF	50	300
015LF	50	300
022LF	50	300
037LF	35	600
055LF/075LFP	17	1000
075LF/110LFP	17	1000
110LF/150LFP	17	1000
150LF/185LFP	8.7	2500
004HF	180	300
007HF	180	300
015HF	180	300
022HF	100	600
037HF	100	600
055HF/075HFP	70	1200
075HF/110HFP	50	1200
110HF/150HFP	50	2000
150HF/185HFP	40	2500
185HF/220HFP	20	3000
220HF/300HFP	20	4000

(Note1) ED is duty cycle, 100sec based (5%ED = 5sec)

(Note2) In case of self-cooled DB

3.2 Dimension

3.2.1 N750E-004SF~007SF, 004LF~015LF

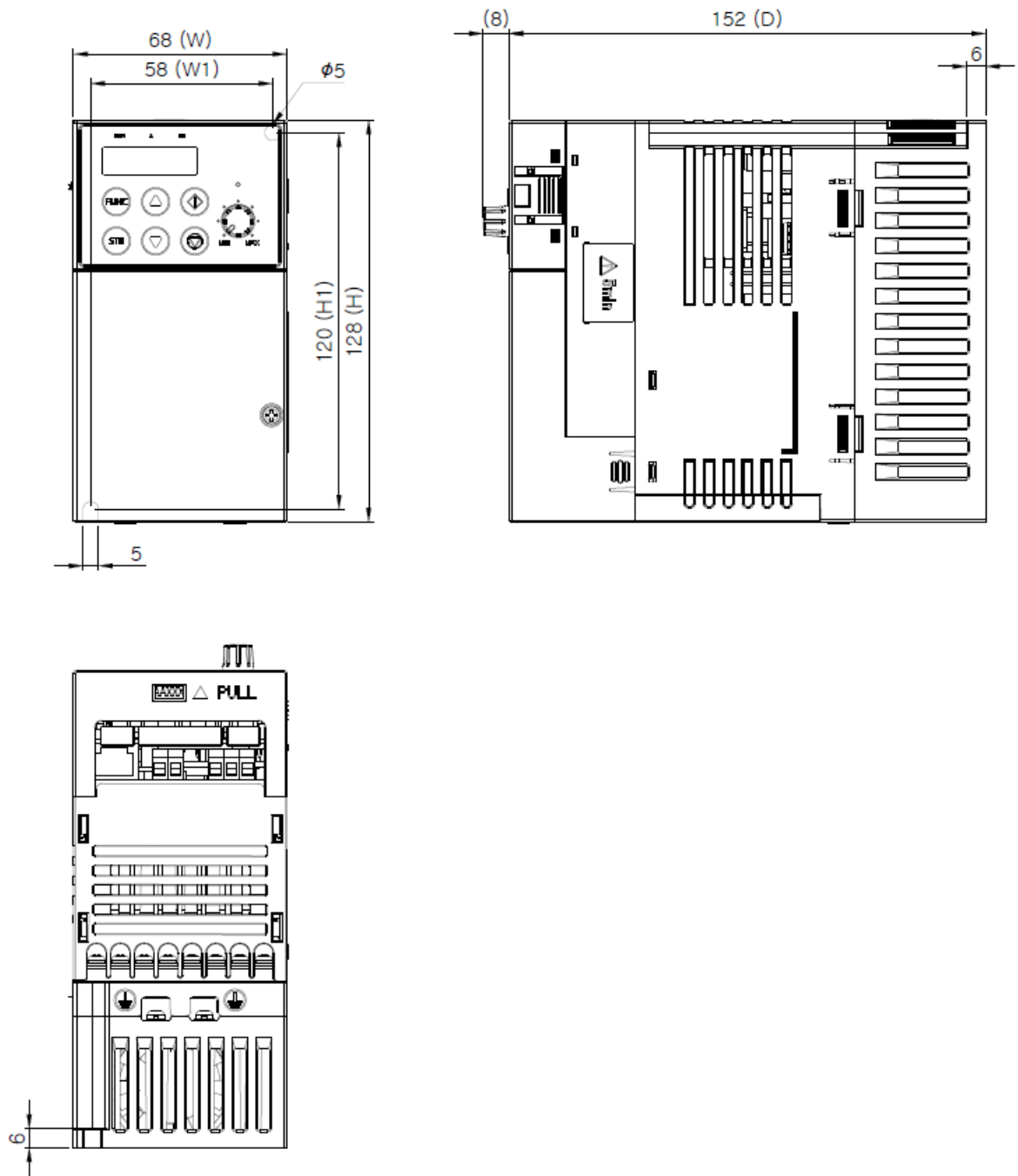

Diemnsions

Model	W [mm]	W1 [mm]	H [mm]	H1 [mm]	D [mm]	ϕ [mm]	Weight [kg]
004SF ~ 007SF	68	58	128	120	149	5	0.76
004LF ~ 015LF	68	58	128	120	149	5	0.76

3.2.2 N750E-015SF~022SF, 022LF, 004HF~022HF

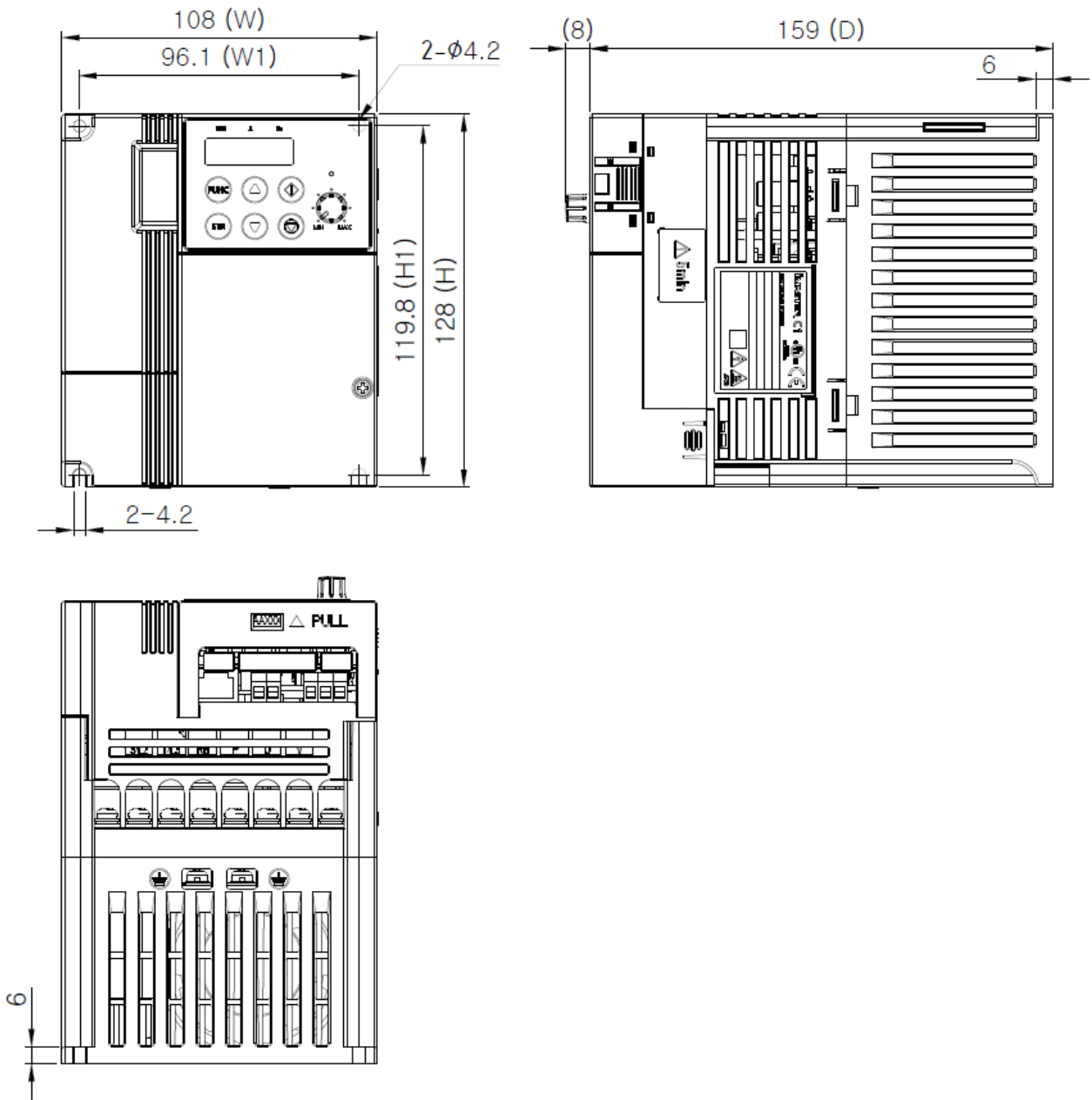

Diemnsions

Model	W [mm]	W1 [mm]	H [mm]	H1 [mm]	D [mm]	ø [mm]	Weight [kg]
015SF ~ 022SF	108	96.1	128	119.8	159	4.2	0.96
022LF	108	96.1	128	119.8	159	4.2	0.96
004HF ~ 022HF	108	96.1	128	119.8	159	4.2	0.96

3.2.3 N750E-037LF, 037HF

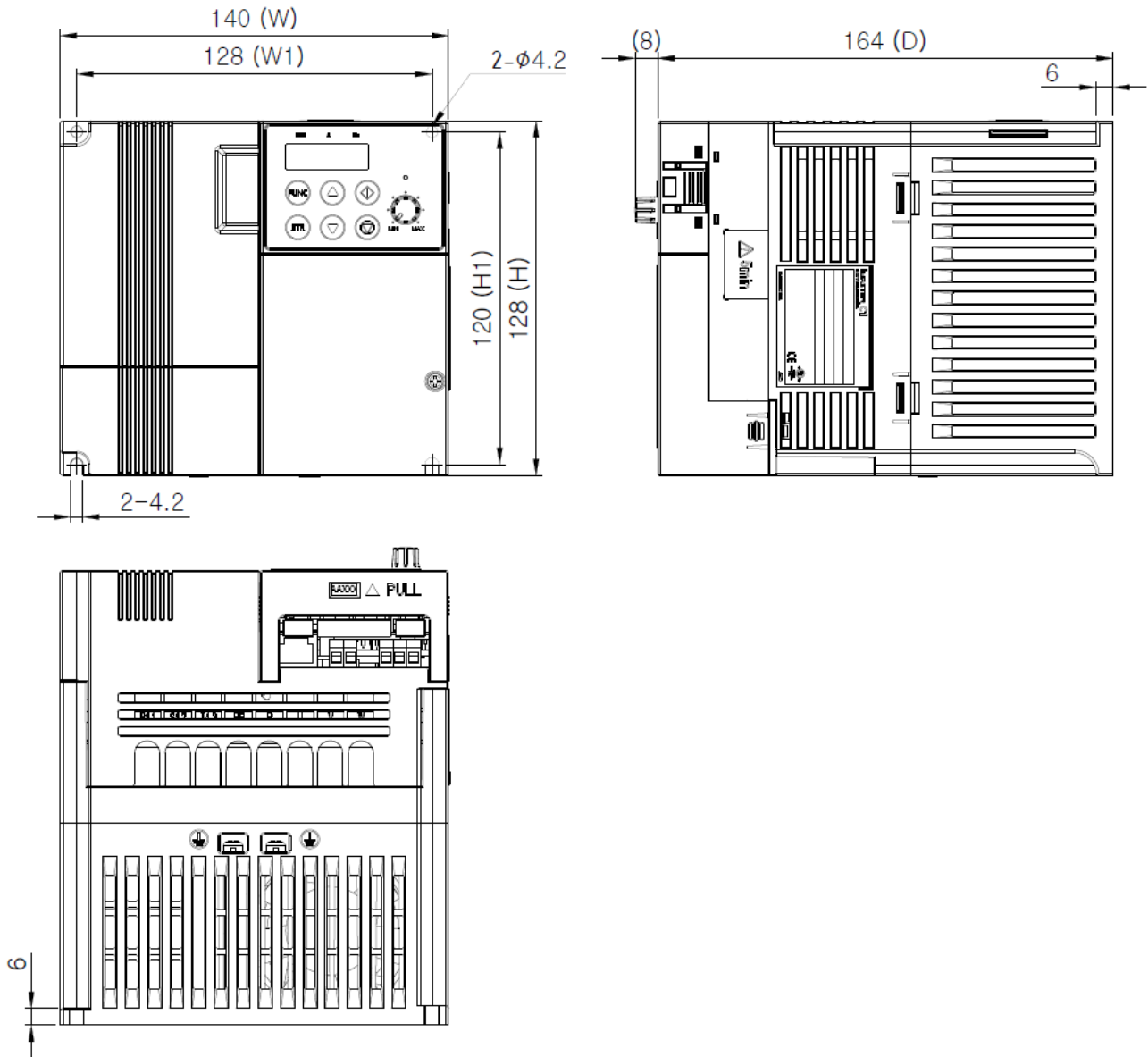

Diemnsions

Model	W [mm]	W1 [mm]	H [mm]	H1 [mm]	D [mm]	ϕ [mm]	Weight [kg]
037LF	140	128	128	120	164	4.2	1.34
037HF	140	128	128	120	164	4.2	1.34

3.2.4 N750E-055LF/075LFP~075LF/110LFP, 055HF/075HFP~075HF/110HFP

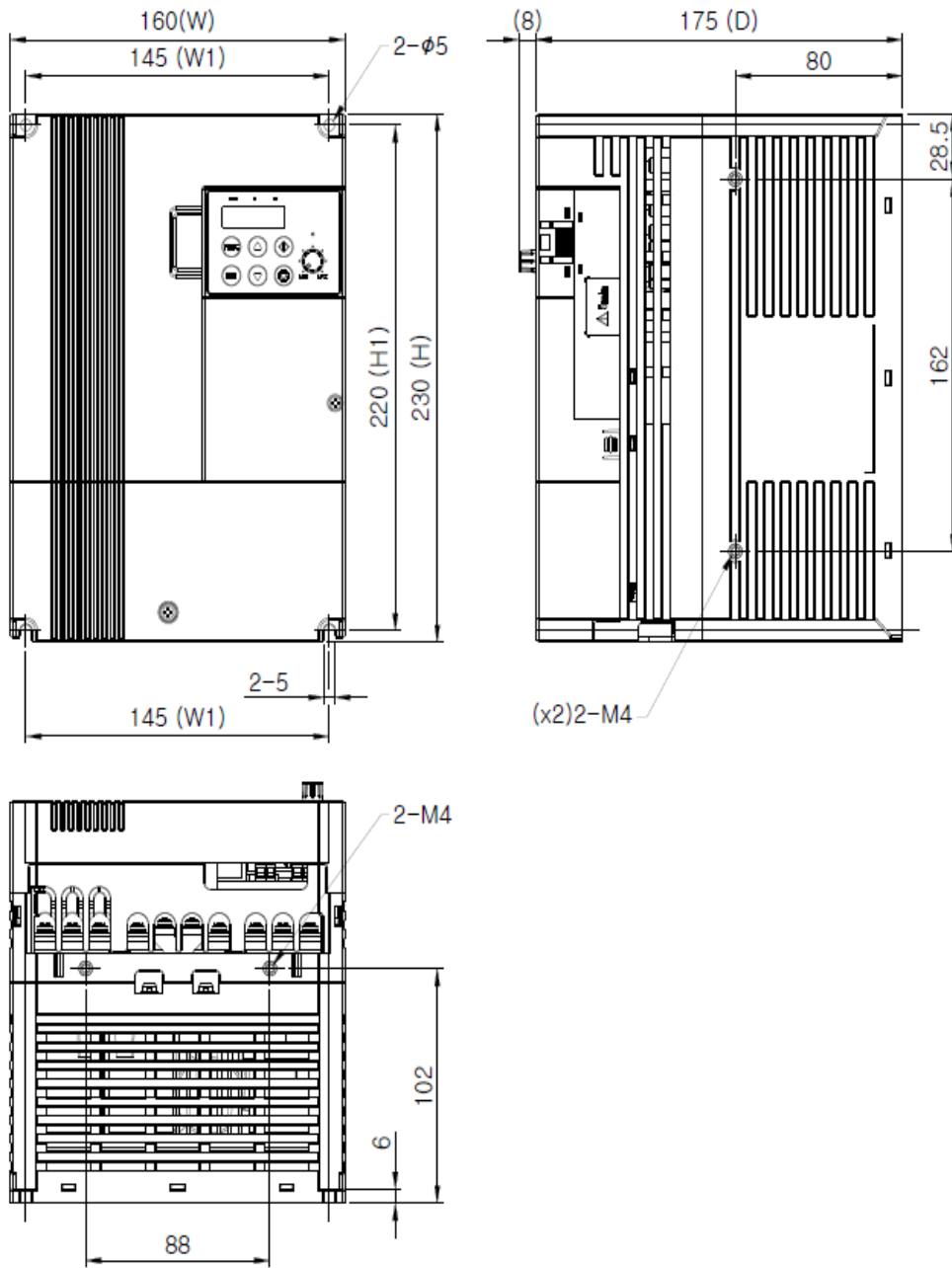

N750E-1Frame Diemnsions

Model	W [mm]	W1 [mm]	H [mm]	H1 [mm]	D [mm]	∅ [mm]	Weight [kg]
055LF/075LFP	160	145	230	220	175	5	2.6
075LF/110LFP	160	145	230	220	175	5	2.6
055HF/075HFP (FLT)	160	145	230	220	175	5	2.5(2.8)
075HF/110HFP (FLT)	160	145	230	220	175	5	2.5(2.8)

3.2.5 N750E-110LF/150LFP, 110HF/150HFP~150HF/185HFP

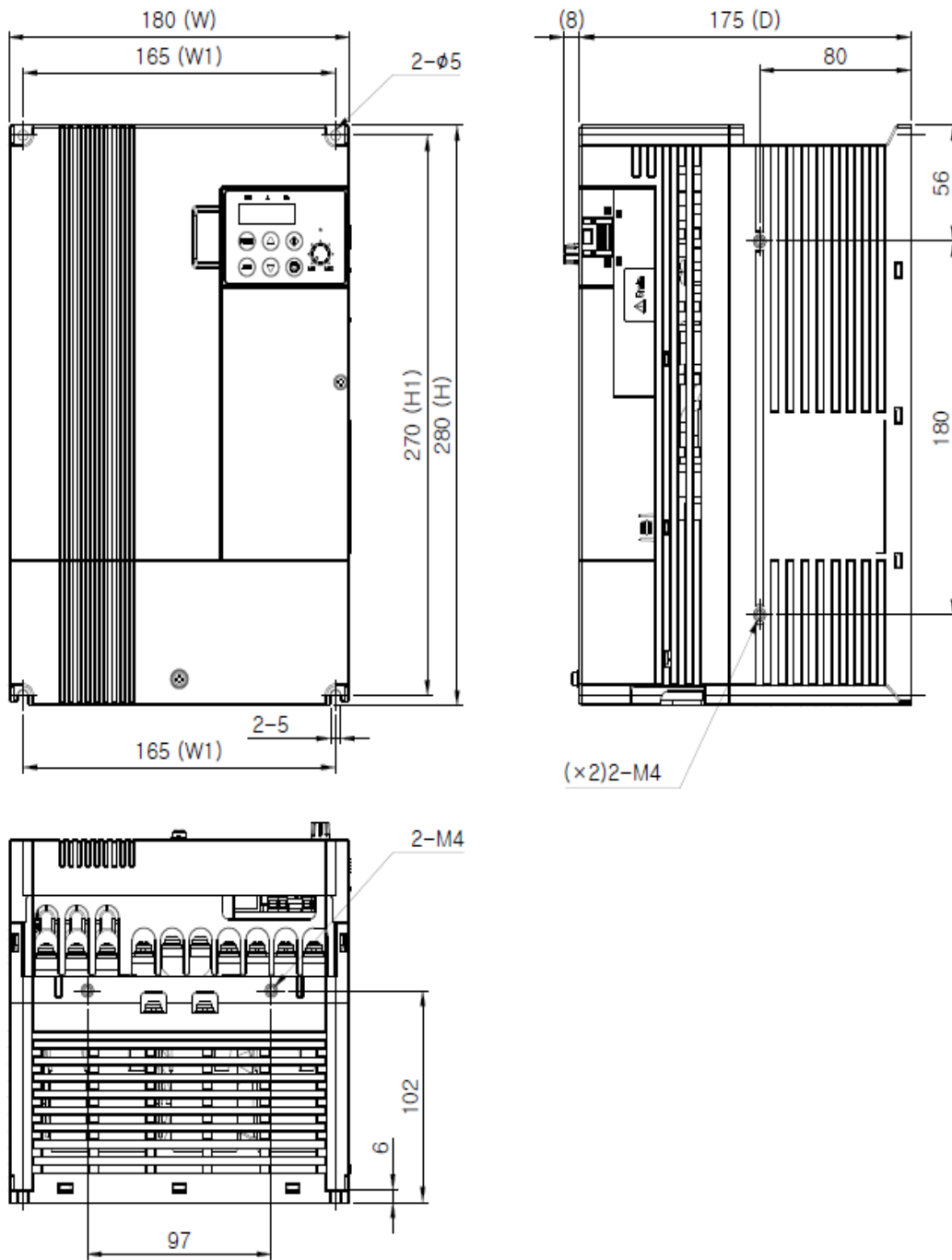

N750E-2Frame Diemsons

Model	W [mm]	W1 [mm]	H [mm]	H1 [mm]	D [mm]	ϕ [mm]	Weight [kg]
110LF/150LFP	180	165	280	270	175	5	3.8
110HF/150HFP (FLT)	180	165	280	270	175	5	3.9(4.1)
150HF/185HFP (FLT)	180	165	280	270	175	5	3.9(4.1)

3.2.6 N750E-150LF/185LFP, 185HF/220HFP~220HF/300HFP

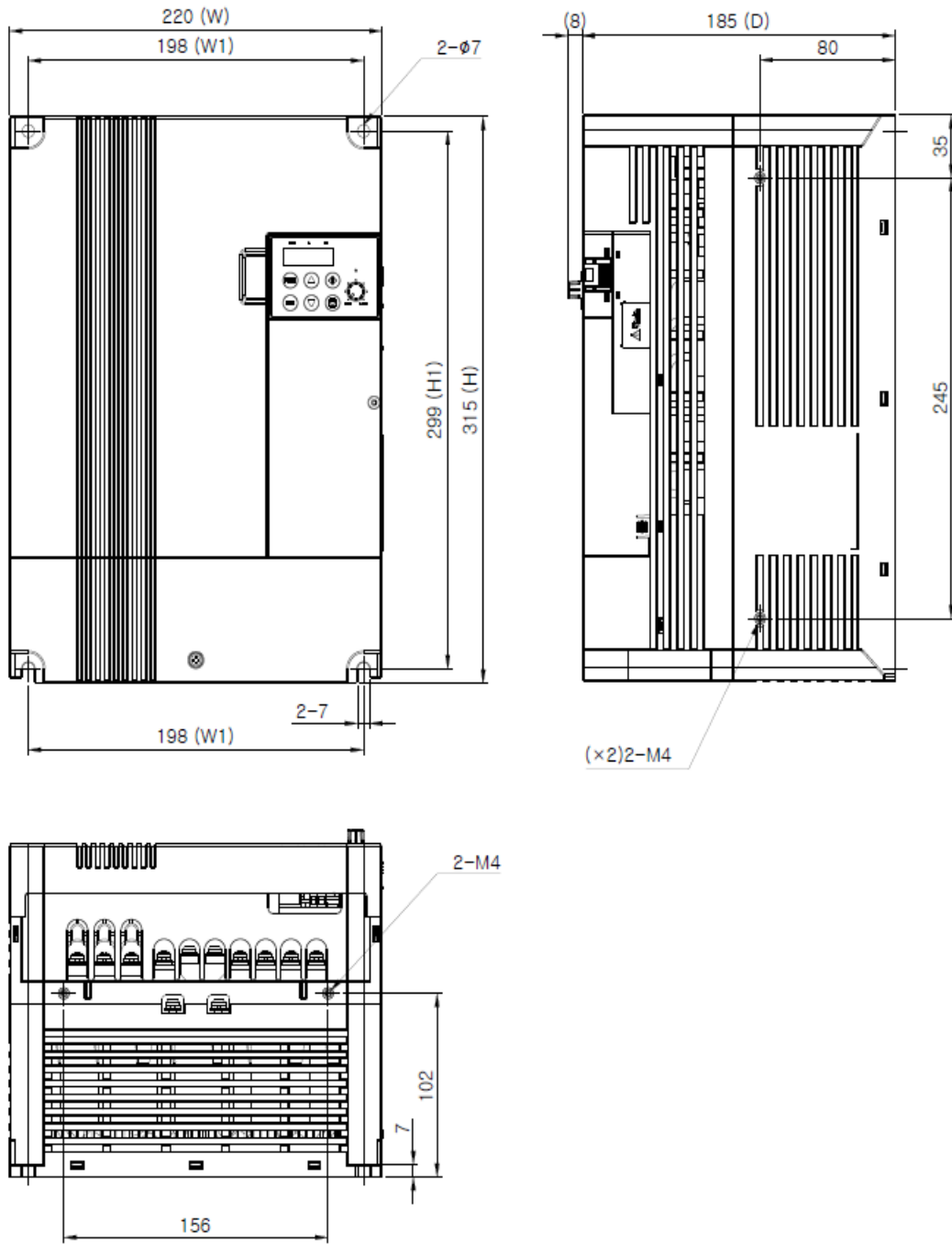

N750E-3Frame Diemnsions

Model	W [mm]	W1 [mm]	H [mm]	H1 [mm]	D [mm]	ϕ [mm]	Weight [kg]
150LF/185LFP	220	198	315	299	185	7	5.5
185HF/220HFP (FLT)	220	198	315	299	185	7	5.8(6.1)
220HF/300HFP (FLT)	220	198	315	299	185	7	5.8(6.1)

4. OPERATION



DANGER

- Be sure not to touch the main terminal or to check the signal add or remove wires and/or connectors.
- Be sure not to turn the input power supply on until after front case is closed.
While the inverter is energized, be sure not to remove the front cover.
- Be sure not to operate the switches with wet hands.
- While the inverter is energized, be sure not to touch the inverter terminals even while the unit is not running.
- If the retry mode is selected, it may suddenly restart during the trip stop.
Be sure not to approach the equipment. (Be sure) to design the equipment so that personnel safety will be secured even if equipment restarts.
- Even if the power supply is cut for a short period of time, the inverter may restart operation after the power supply is restored if the operation command is given.
If a restart may incur danger to personnel, be sure to make a circuit so that it will not restart after power recovery.
- The stop key is valid only when a function is on. Ensure that there is a hardware emergency stop that is separate from the stop key of the inverter.
- With the operation command on, if the alarm reset is ordered, the inverter can restart suddenly. Be sure to set the alarm reset after checking the operation command is off.
- Be sure not to touch the inside of the energized inverter or to put a bar into it.



CAUTION

- The cooling fins will have high temperature. Be sure not to touch them.
- Low to high speed operation of the inverter can be easily set. Be sure to operate it after checking the tolerance of the motor and machine.
- Install an external braking system if needed.
- If a motor is operated at a frequency higher than standard setting value(50Hz/60Hz), be sure to check the speeds of the motor and the machine from their manufacturers.
After getting their consent, operate them.

4.1 Keypad overview

N750E inverter's digital operator is LED type. Please use attached LED operator for running.

4.1.1 Keypad description

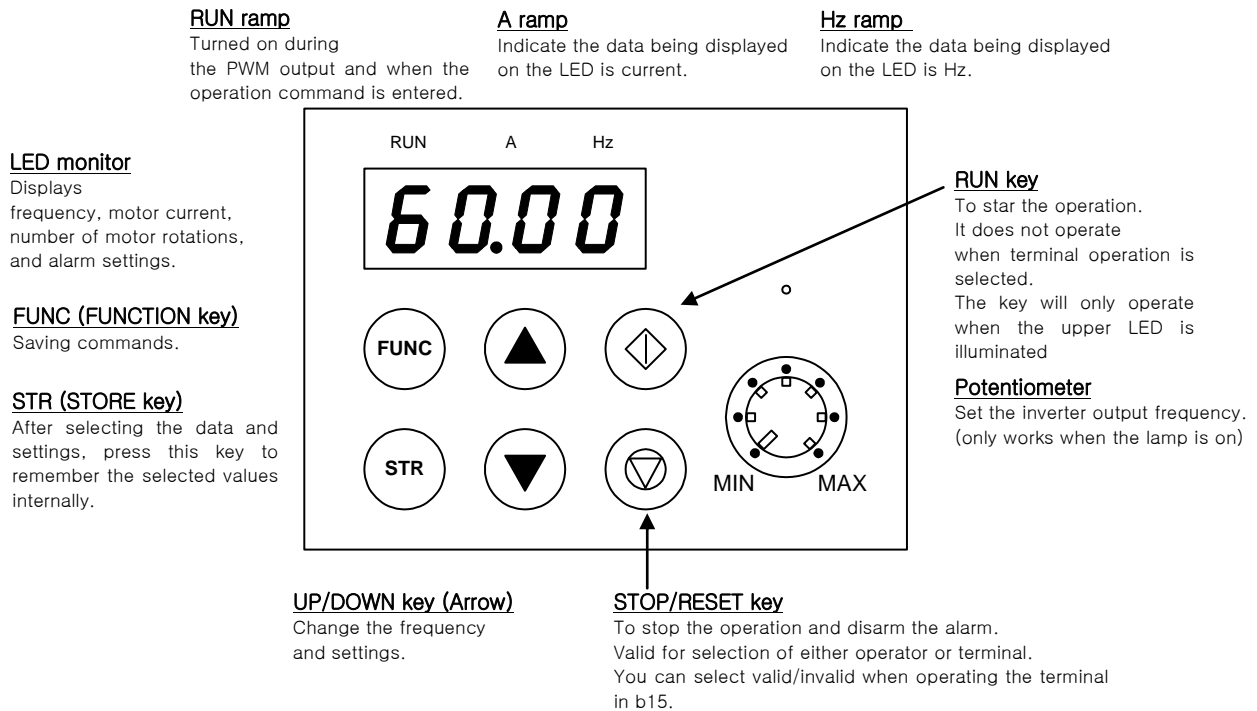

Figure 4-1 LED Keypad description



Initial keypad display description

Default mode of keypad display is d01 – output frequency of inverter. Enter b30, you can set the mode of display: d01~d13.

4.1.2 Keypad navigation

1) Keypad navigation

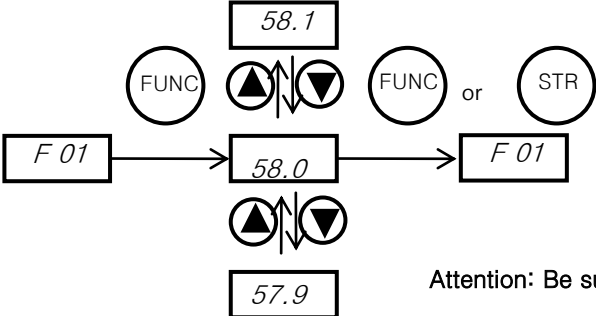
Table 4-1 Keypad navigation

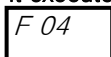
Key	Function description	
<p>FUNC</p>	<p>[FUNC(FUNCTION key)] . . . Use to switch mode to command saving, data setting, extension function and default mode. Pressing this key will change the display to the following at any time.</p>  <p>Attention: Be sure press  for saving.</p>	
<p>RUN</p>	<p>[RUN key] It executes the inverter to running.  determines a forward run or reverse run.</p>	
<p>STOP/RESET</p>	<p>[STOP/RESET key] . . . It executes the inverter to stop. For trips, it reset the inverter.</p>	
<p>▲ ▼</p>	<p>[UP key, DOWN key]) . . . Select the value of setting or command by moving key.</p>	

※ Attention for STR key

If you want to store the data using STR key, please stay at least 6sec without any change or moving up/down key.

If you change anything such as key operations, reset operations, and power down before 6 seconds, the correct data may not be stored.

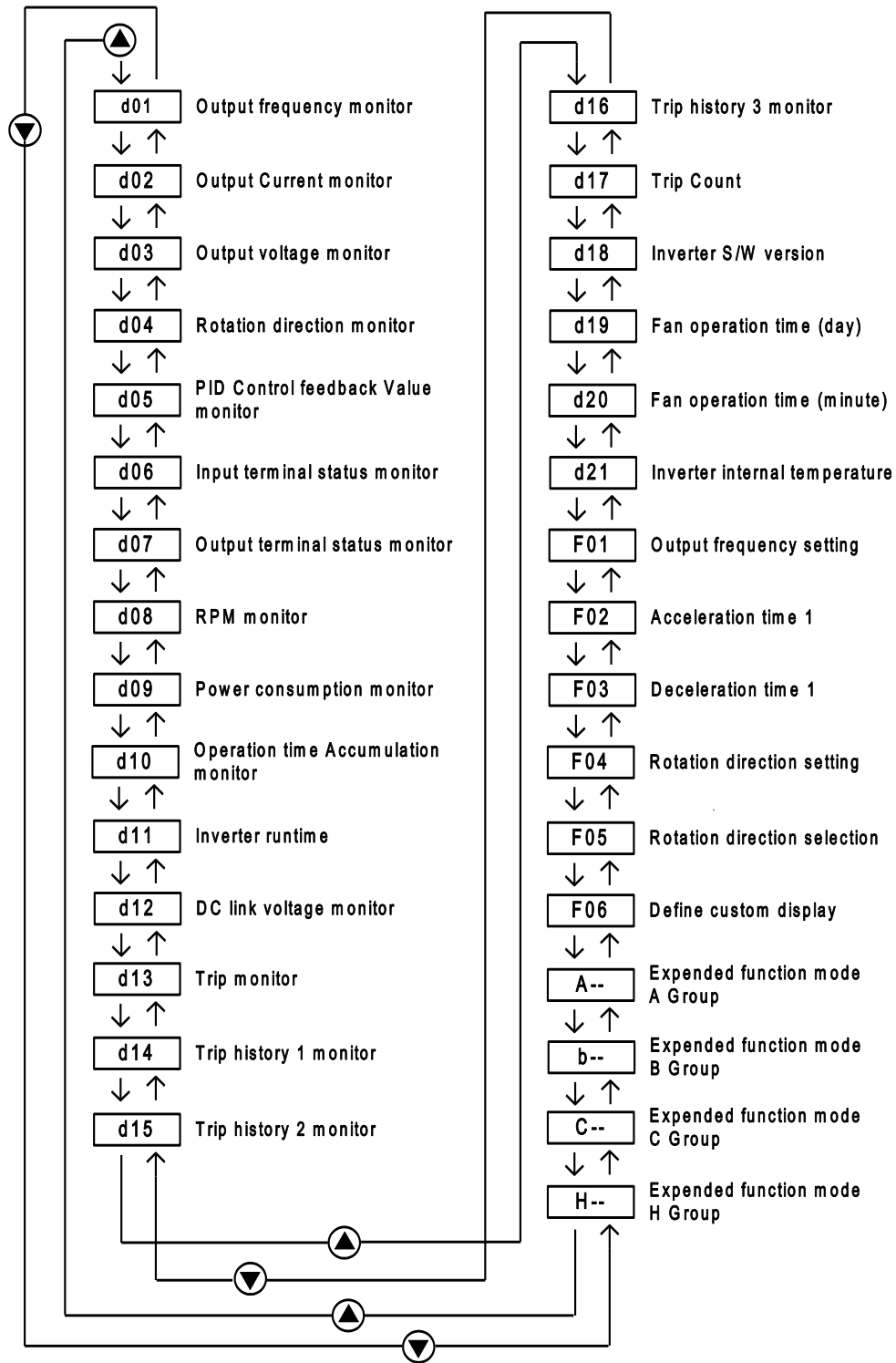

Figure 4-2 Up/Down key basic operation

2) Expanded function mode navigation

Using the ▲ / ▼ key to enter the expanded function mode, select expanded Function command NO. in **A--** **b--** **C--** and **H--** mode.

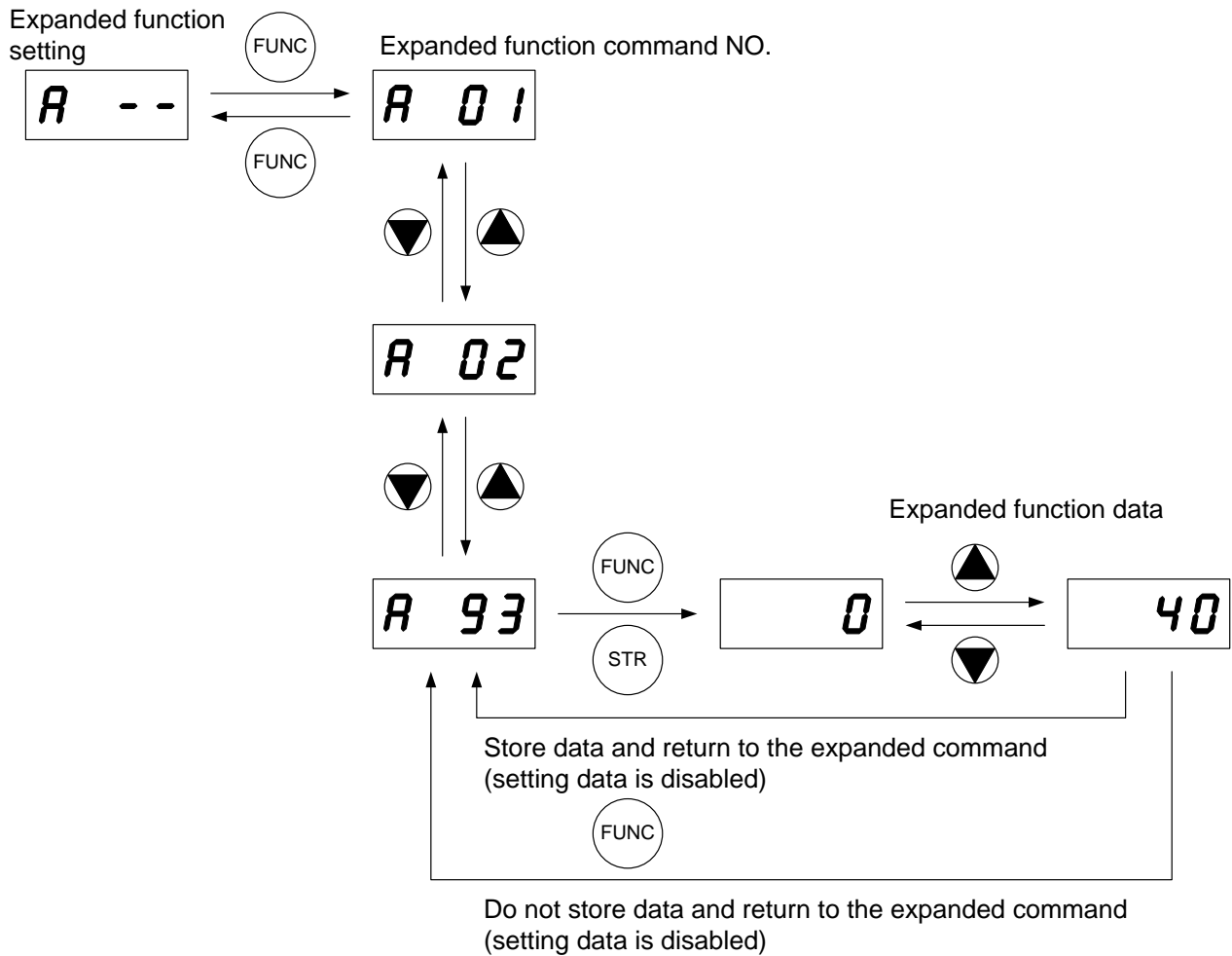

Figure 4-3 Expanded function mode navigation

3) Navigation example: Mode change with arrow keypad
 (Change the way of frequency setting from potentiometer to up/down key.
 Running the inverter by up/down key operation)

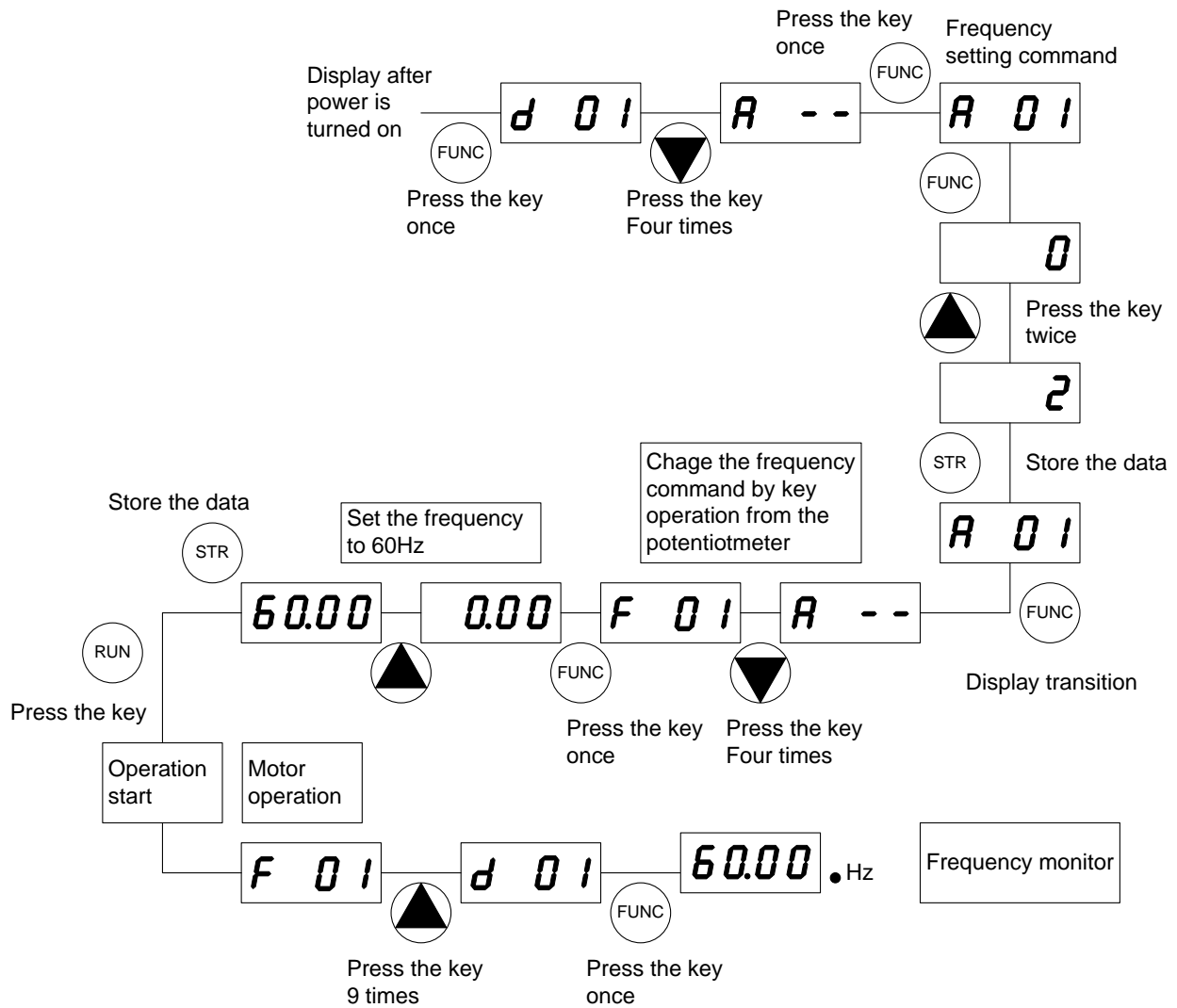

Figure 4-4 Navigation example: Mode change with arrow keypad

4.1.3 Shift key function

The "SHIFT" function is enabled to press both up and down key simultaneously. The left segment digit is blinked and if press store key, the blinked segment moves to the right digit.

When the 'store' key is pressed, it moved to the right digits again.

When the right most digit is blinked and press the 'store' key, it turned back to the function code display.

1. Display digit movement

- Press the UP key and Down key at the same time in data setting mode.
→ Change scroll mode to shift mode.

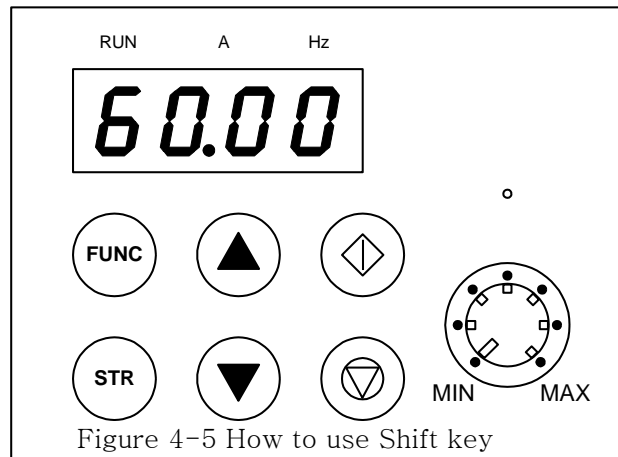

2. Data setting method

Stop in target group using UP/DOWN key → Press the function key, Change to data setting mode.

- 1) Press the UP key and DOWN key at the same time. → First number is flashing on the left
- 2) Change the data using UP/DOWN key → Press the Store-key → Third number is flashing.
- 3) Change the data using UP/DOWN key → Press the Store-key → Second number is flashing
- 4) Change the data using UP/DOWN key → Press the Store-key → First number is flashing
- 5) Change the data using UP/DOWN key → Press the Store-key → Target function code is setting

4.2 Frequency and run sources

In order to run the inverter, the run command source and frequency command source must be determined. Select one frequency command source and one run command source from list below and follow the instruction in the section referenced

4.2.1 Control terminal operation

Connect external signal to control terminal then running the inverter with this signal. Start operation by operation command (FW, RV) after inverter turning on. However, there are 2 ways for setting the terminal frequency – run or frequency command, please select for each system.

For detailed specifications, refer to the control circuit terminal description (required for operation)

- 1) Run command: The inverter is run/stop by external signal inputs such as switches and relays.
(Please refer 4-3)
- 2) Frequency command: Operating frequency is determined external signals 0 to 10V or 4 to 20mA.
(Please refer 4-3)

4.2.2 Digital keypad operation

Operation the inverter with mounted keypad – arrow key and potentiometer.

<Operation navigation>

1. Set frequency command source to potentiometer (A01=0)
2. Set run command source to standard operator (A02=0)
3. Press RUN button on the mounted operator, inverter will be run.
4. Change frequency using potentiometer.
(If set A01=2, can change frequency with up/down key ▲▼.)

4.2.3 Combination control terminal and digital keypad

Operation the inverter with combined way.

You can select the way of setting for frequency command and run command each.

4.2.4 Communication (RS-485) operation

The inverter can be driven by a communication command from an external control device, such as a PLC. You can also control the inverter through the optional Remote Operator (ROP). See '6. Communication Functions' for details.

4.3 Test run

This is an example of a common connection. If you prefer to use digital operator, please refer to detailed use of the digital operator.

4.3.1 To input the operation setting and the frequency setting from the terminal

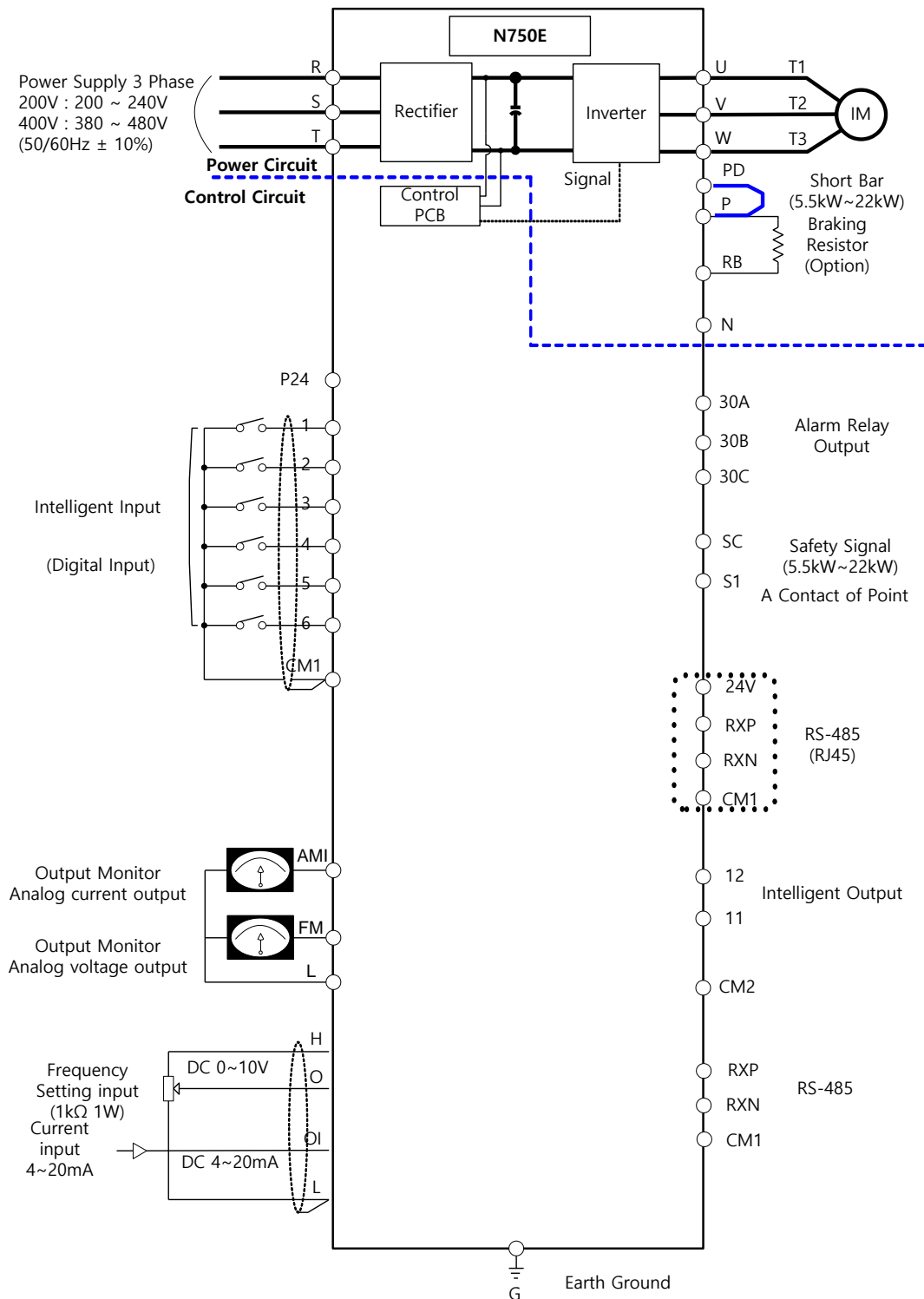

Figure 4-6 Setting diagram from the terminal

<Procedure>

(1) Please make sure that the connections are secured correctly.

- Connect the power supply to R(L1), S(L2), T(L3)
- Connect the motor to U(T1), V(T2), W(T3)

(2) Turn on power supply to the inverter

- Please make sure the operator should illuminate.

(3) Set the terminal with the frequency setting selection.

- Set A01 as the indication code, press the **FUNC** once. (Code values are shown)
- Set 1 with **▲**, press the **STR** once to set the operation setting for the operator.
(Indication code turns back to A01)

(4) Set terminal with the operation setting selection.

- Set A02 as indication code, press the **FUNC** once.
- Set 1 with the **▲ ▼** key, press the **STR** key once to set the operation setting for the operator.
(Indication code turns back to A02.)

(5) Set monitor mode

- When monitoring the output frequency, set indication code to d01.
Or when monitoring the operation direction, set indication code to d04.

(6) Input start operation setting

- Turn on between [FW) and [CM1] of terminal.
(Run command to the inverter)
- Apply voltage [O] and [L] of terminal to start operation.
(Frequency command to the inverter)

(7) Input stop operation setting.

- Turn OFF between [FW (1)] and [CM1] to slowly stop.

4.3.2 Operation setting and the frequency setting from the digital operator

(Remote operator is also same use.)

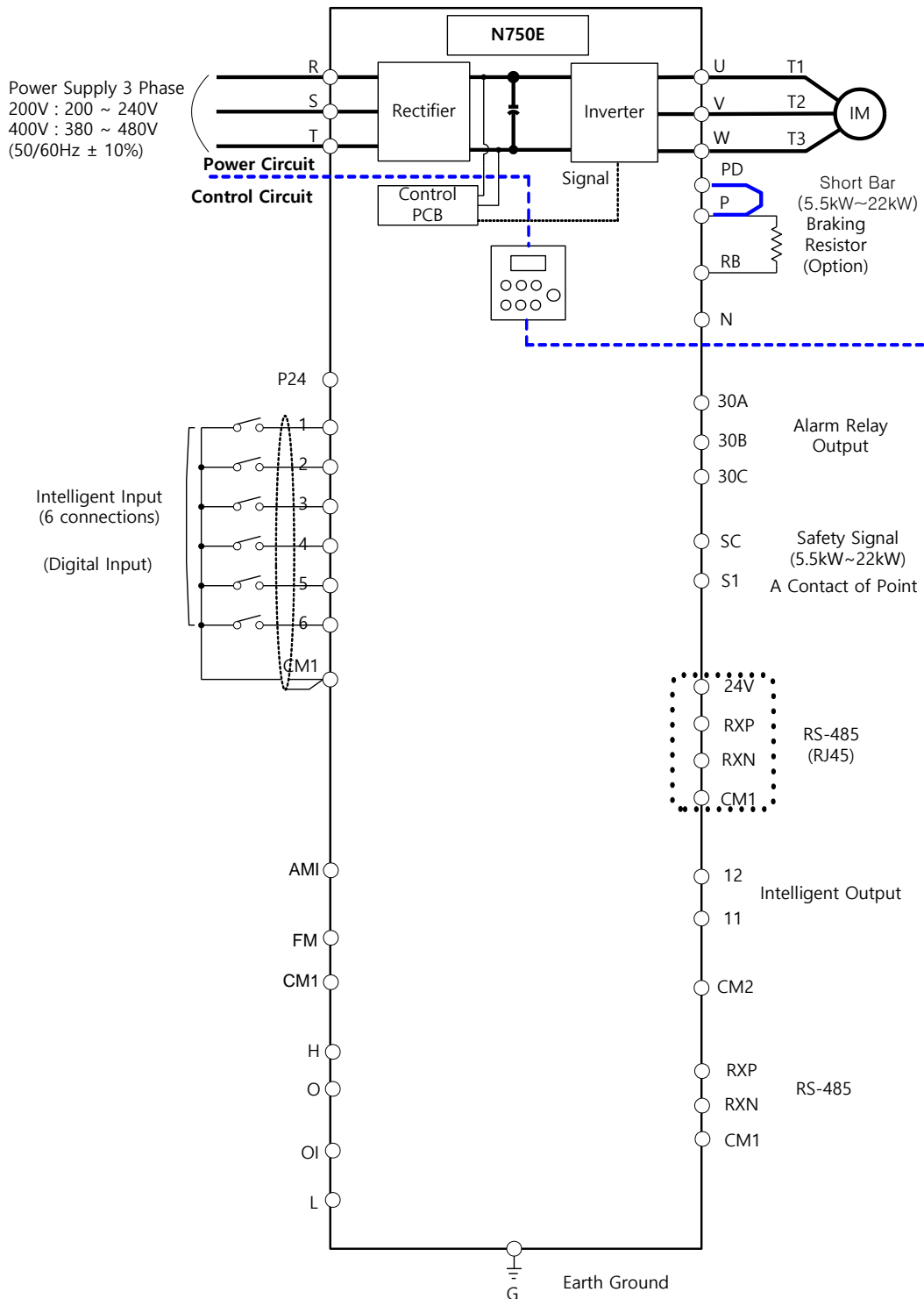

Figure 4-7 Setting diagram from the digital operator

<Procedure>

(1) Please make sure that the connections are secured correctly.

- Connect the power supply to R(L1), S(L2), T(L3)
- Connect the motor to U(T1), V(T2), W(T3)

(2) Turn on power supply to the inverter.

- Please make sure the operator should illuminate.

(3) Set the operator with the frequency setting selection.

- Set A01 as indication code, press the **FUNC** key once. (Code values are shown.)
- Set 2 with **▲** key (In case of remote is 3), press **STR** key once to set the operation setting for the operator. (Indication code turns back to A01.)

(4) Set the operator with the operation setting selection.

- Set A02 as the indication code, and set 2. Press **STR** key to set the operation setting.

(5) Set the output frequency.

- Set F01 as indication code, and pressing **FUNC** key once. (Code values are shown.)
- Set to the desired output frequency with **▲**, **▼** key, press **STR** key once to store it.

(6) Set Monitor mode.

- When monitoring the output frequency, set indication code to d01.
Or when monitoring the operation direction, set indication code to d04.

(7) Press the **RUN key to start operating.**

- "Run" lamp turns on a light.

(8) Press the **STOP key to decelerate to a stop.**

- When the frequency returns to 0, the RUN lamp light will switch off.

- Check whether there is no trip, number of turns, and frequency meter are correct during operation.
- Set the accel/decel time longer, when an over-current trip or over-voltage trip occurs.

5. PARAMETERS

iMaster C1 parameters are organized to various groups as summarized

- d group: Monitoring
- F group: Basic Frequency Setting
- A group: Extended Frequency Setting
- b group: Extended Start/Stop
- C group: Input / Output Terminal
- H group: Motor

5.1 Parameter Group Overview

5.1.1 Monitoring (d group)

Table 5-1 Monitor mode (d group)

Func-code	Name	Description	Page
d01	Output frequency monitor	Display of output frequency	5-20
d02	Output current monitor	Display of output current	5-20
d03	Output voltage monitor	Display of output voltage	5-20
d04	Rotation direction monitor	Display of direction of operation	5-20
d05	PID feedback monitor	Displays the scaled PID process variable (%)	5-20
d06	Intelligent input terminal monitor	Displays the state of the intelligent input terminals	5-20
d07	Intelligent output terminal monitor	Displays the state of the intelligent output terminals	5-20
d08	RPM monitor	Display of output RPM	5-20
d09	Power consumption monitor	Display of power consumption	5-20
d10	Operation accumulated time(day)	Display of cumulative time (day)	5-20
d11	Operation accumulated time (minute)	Display of cumulative time (minute)	5-21
d12	DC link voltage	Display of DC link voltage	5-21

5.1.2 Trip monitor (d group)

Table 5-2 Trip monitor mode (d group)

Func-code	Name	Description	Page
d13	Trip event monitor	Display the current trip event	5-21
d14	Trip history 1 monitor	Display the previous first trip event	5-21
d15	Trip history 2 monitor	Display the previous second trip event	5-21
d16	Trip history 3 monitor	Display the previous third trip event	5-21
d17	Trip count	Displays the trip accumulation count	5-21
d18	Inverter S/W version	Display software version of inverter	5-21
d19	Fan operation time (day)	Display fan accumulation time (day)	5-21
d20	Fan operation time (minute)	Display fan accumulation time (minute)	5-21
d21	Inverter internal temperature	Display Inverter internal temperature (°C)	5-22

5.1.3 Basic function (F group)

Table 5-3 Basic function mode (F group)

Func-code	Name	Range	Defaults	Runtime edit	Page
F01	Output frequency setting	0.00~400.0[Hz] Sensorless 0.00~300.0 [Hz]	0.00Hz	O	5-22
F02	Acceleration time 1 setting	0.1 ~ 6000 [sec]	5.0 sec	O	5-22
F03	Deceleration time 1 setting	0.1 ~ 6000 [sec]	10.0 sec	O	5-22
F04	Rotation direction setting	0 - Forward 1 - Reverse	0	X	5-22
F05	Rotation direction selection	0 – Enable both way (FW and RV) 1 – Disable forward 2 – Disable reverse	0	X	5-22
F06	Define custom display	0 ~ 65535	1.0	O	5-22

5.1.4 Extended function A mode (A group)

Table 5-4 Extended function A mode (A group)

Func-code	Name	Range	Defaults	Runtime edit	Page
Basic parameter setting					
A01	Frequency command (Multi-speed command method)	0 – Keypad potentiometer 1 – Control terminal input 2 – Standard operator 3 – Remote operator (1 st communication -RJ45) 4 – Remote operator (2 nd communication - terminal) 5 – Option 6 – Potentiometer and remote	1	X	5-23
A02	Run command	0 – Standard operator 1 - Control terminal input 2 - Remote operator (RJ45) 3 - Remote operator (Terminal) 4 – Option	1	X	
A03	Base frequency setting	0.00 ~ Max. frequency(A04) [Hz]	60.00Hz	X	
A04	Maximum frequency setting	Base frequency (A03) ~ 400 [Hz] In case of sensorless vector (A31=2), Base frequency (A03) ~ 300 [Hz]	60.00Hz	X	
Analog Input Settings (External frequency setting)					
A05	External frequency setting start (O, OI)	0.00 ~ Max. frequency (A04) [Hz]	0.00Hz	X	5-23
A06	External frequency Setting end (O, OI)	0.00 ~ Max. frequency (A04) [Hz]	0.00Hz	X	
A07	External frequency start rate setting (O, OI)	0.0~100.0 [%]	0.0%	X	5-24
A08	External frequency end rate setting (O, OI)	0.0~100.0 [%]	100.0%	X	
A09	External frequency start pattern setting	0 – Start at start frequency (A05) 1 – Start at 0 Hz	0	X	
A10	External frequency sampling setting	0.1~500.0	1.0	X	

Func-code	Name	Range	Defaults	Runtime edit	Page
Multi-speed Frequency Setting					
A11 ~ A25	Multi-speed frequency setting	0.00 ~ Max. frequency (A04) [Hz]	speed1:5Hz speed2:10Hz speed3:15Hz speed4:20Hz speed5:30Hz speed6:40Hz speed7:50Hz speed8:60Hz etc. 0Hz	O	5-24
A26	Jogging frequency setting	0.50~10.00 [Hz]	0.50Hz	O	5-25
A27	Jogging stop operation selection	0 – Free-run stop 1 – Deceleration stop (depending on deceleration time) 2 – DC injection braking stop (necessary to set DC injection braking)	0	X	
V/F Characteristics					
A28	Torque boost mode selection	0 – Manual torque boost 1 – Automatic torque boost * For use automatic torque boost, Need to set for motor (H group)	0	X	5-25
A29	Manual torque boost setting (forward)	0.0~50.0 [%]	(Note 1)	O	5-26
A30	Manual torque boost Frequency setting (forward)	0.0~100.0 [%]	100.0%	O	5-26
A31	V/F characteristic curve selection	0 – Constant torque 1 – Reduced torque (reduction of the 1.7thpower) 2 – Sensorless vector control 3 – VF_USER	0	X	5-26
A32	V/F gain setting	20.0~110.0 [%]	100.0%	O	5-26

(Note 1) Depends on inverter power range

200V Class

3.7kW or less:2.0[%], 5.5kW:2.3[%], 7.5kW:2.1[%], 11kW:1.9[%], 15kW:1.7[%]

400V Class

3.7kW or less:2.0[%], 5.5kW:2.3[%], 7.5kW:2.1[%], 11kW:1.9[%], 15kW:1.7[%], 18.5kW:1.6[%],22kW:1.5[%]

Func-code	Name	Range	Defaults	Runtime edit	Page
DC Injection Braking Settings					
A33	DC injection braking function selection	0 – Disable 1 – Enable	0	X	5-27
A34	DC injection braking Frequency setting	0.50~10.00 [Hz]	0.50Hz	X	
A35	DC injection braking output delay time setting	0.0~5.0 [sec]	0.0 sec	X	
A36	DC injection braking force setting	0.0~100.0 [%]	(Note2)	X	
A37	DC injection braking time setting	0.0~10.0 [sec]	0.0 sec	X	
Frequency-related Functions					
A38	Frequency upper limit setting	Frequency lower limit (A39) ~ Max. frequency (A04) [Hz]	0.00Hz	X	5-28
A39	Frequency lower limit setting	0.00~Frequency upper limit (A38) [Hz]	0.00Hz	X	
A40 A42 A44	Jump(center)frequency setting	0.00~ Max. frequency (A04) [Hz]	0.00Hz	X	
A41 A43 A45	Jump(hysteresis) frequency width setting	0.00~10.00 [Hz]	0.00Hz	X	5-29
A46	Manual torque boost setting (Reverse)	0.0~50.0 [%]	(Note 3)	O	
A47	Manual torque boost Frequency setting (Reverse)	0.0~100.0 [%]	100.0%	O	
A48	Auto torque boost voltage gain	0.00~2.50 [x1]	x1.00	O	
A49	Auto torque boost filter time constant	0.1~999.9 [ms]	80.0 ms	O	

(Note 2) 50.0% ($\leq 22\text{kW}$)

(Note 3) Depends on inverter power range

200V Class

3.7kW or less:2.0[%], 5.5kW:2.3[%], 7.5kW:2.1[%], 11kW:1.9[%], 15kW:1.7[%]

400V Class

3.7kW or less:2.0[%], 5.5kW:2.3[%], 7.5kW:2.1[%], 11kW:1.9[%], 15kW:1.7[%], 18.5kW:1.6[%],22kW:1.5[%]

Func-code	Name	Range	Defaults	Runtime edit	Page
Automatic Voltage Regulation (AVR) Function					
A52	AVR function selection	0 – Constant ON 1 – Constant OFF 2 – OFF during deceleration	2	X	5-29
A53	Motor voltage setting	200V Class - 80~240V 400V Class - 160~500V	(Note 4)	X	
Second Acceleration and Deceleration Functions					
A54	Second acceleration time setting	0.0~6000 [sec]	5.0 sec	O	5-30
A55	Second deceleration time setting	0.0~6000 [sec]	10.0 sec	O	
A56	Two stageacce1/dece1 switching method selection	0 – 2CH input from terminal 1 – Transition frequency from acc/dec1 to acc/dec2	0	X	
A57	Acc1 to Acc2frequency transition point ^{note5}	0.00~Max.frequeuncy (A04) [Hz]	0.00Hz	X	
A58	Decel 1 to Decel 2 frequency transition point ^{note5}	0.00~Max.frequeuncy (A04) [Hz]	0.00Hz	X	
A59	Acceleration curve selection	0 – Linear 1 – S curve 2 – U curve	0	X	
A60	Deceleration curve setting	0 – Linear 1 – S curve 2 – U curve	0	X	5-31
Others					
A61	Input voltage offset setting	-10.0~10.0 [%]	0.0%	O	5-31
A62	Input voltage gain setting	0.0~200.0 [%]	100.0%	O	
A63	Input current offset setting	-10.0~10.0 [%]	0.0%	O	
A64	Input current gain setting	0.0~200.0 [%]	100.0%	O	
A65	FAN operation mode	0 - always ON 1 - ON when operation 2 - ON according to the inverter inside temperature	0	X	

(Note 4) SF/LF/LFP : 220V, HF/HFP : 380V

(Note 5) If the acceleration and deceleration times are set to a value less than or equal to 1 second, the saving frequency will be inaccurate.

Func-code	Name	Range	Defaults	Runtime edit	Page
S curve ratio setting					
A66	S curve start ratio setting of acceleration	0.0~100.0[%]	50.0%	O	5-32
A67	S curve stop ratio setting of acceleration	0.0~100.0[%]	50.0%	O	
A68	S curve start ratio setting of deceleration	0.0~100.0[%]	50.0%	O	
A69	S curve stop ratio setting of deceleration	0.0~100.0[%]	50.0%	O	
PID Control					
A70	PID Function selection	0 – PID control disable 1 – PID control enable 2 – F/F control enable 3 – PID control enable at Stop 4 – PID,F/F control enable at Stop	0	X	5-33
A71	PID Reference	0.00 ~ 100.0 [%]	0.00%	O	
A72	PID Reference source	0 – Keypad potentiometer 1 – Control terminal input 2 – Standard operator 3 – Remote operator (RJ45) 4 – Remote operator (Terminal) 5 – Option 6 – Potentiometer and RJ45	2	X	
A73	PID Feed-back source	0 – Current input (OI) 1 – Voltage input (O)	0	X	
A74	PID P gain	0.1 ~ 1000.0 [%]	100.0%	O	
A75	PID I gain	0.0 ~ 3600.0 [sec]	1.0sec	O	
A76	PID D gain	0.00 ~ 10.00 [sec]	0.00sec	O	
A77	PID Err limit	0.0 ~ 100.0 [%]	100.0%	O	5-34
A78	PID Output high limit	PID Output low limit (A79) ~ 100.0 [%]	100.0%	O	

Func-code	Name	Range	Defaults	Runtime edit	Page
A79	PID Output low limit	- 100.0 ~ PID Output high limit (A78) [%]	0.0%	O	5-34
A80	PID Output reverse	0 – PID output reverse disable 1 – PID output reverse enable	0	X	
A81	PID scale factor	0.1 ~ 1000.0 [%]	100.0%	X	
A82	Pre PID frequency	0.00 ~ Max. frequency(A04) [Hz]	0.00Hz	X	5-35
A83	Sleep frequency	0.00 ~ Max. frequency(A04) [Hz]	0.00Hz	X	
A84	Sleep/wake up delay time	0.0 ~ 30.0 [sec]	0.0sec	X	
A85	Wake up frequency	0.00 ~ Max. frequency(A04) [Hz]	0.00Hz	X	
Set user V/F pattern ratio					
A86	User V/F setting frequency 1	0 ~ V/F setting frequency 2 (A88)	15.00Hz	X	5-38
A87	User V/F setting voltage 1	0 ~ V/F setting voltage 2 (A89)	25.0%	X	
A88	User V/F setting frequency 2	V/F setting frequency 1 (A86) ~ V/F setting frequency 3 (A90)	30.00Hz	X	
A89	User V/F setting voltage 2	V/F setting voltage 1 (A87) ~ V/F setting voltage 3 (A91)	50.0%	X	
A90	User V/F setting frequency 3	V/F setting frequency 2 (A88) ~ V/F setting frequency 4 (A92)	45.00Hz	X	
A91	User V/F setting voltage 3	V/F setting voltage 2 (A89) ~ V/F setting voltage 4 (A93)	75.0%	X	
A92	User V/F setting frequency 4	V/F setting frequency 3 (A90) ~ Max. frequency (A04)	60.00Hz	X	
A93	User V/F setting voltage 4	V/F setting voltage 3 (A91) ~ 100.0 [%]	100.0%	X	
A94	FAN fault Detection	0 – Ignore FAN fault 1 – Display FAN fault 2 – Display Alarm(FAnt)	1	X	5-39

5.1.5 Extended function b mode (b group)

Table 5-5 Extended function b mode (b group)

Func-code	Name	Range	Defaults	Runtime edit	Page
Restart Mode					
b01	Selection of restart mode	0 – Alarm output after trip 1 – Restart at 0Hz 2 – Resume operation after frequency matching 3 – Resume previous freq. after freq. matching, then decelerate to stop. And display trip info.	0	X	5-40
b02	Allowable instantaneous power failure time setting	0.3~10.0 [sec]	1.0 sec (Note 6)	X	
b03	Reclosing standby after instantaneous power failure recovered	0.3~10 [sec]	1.0 sec	X	
Electronic Thermal Setting					
b04	Electronic thermal level setting	Motor rated current x 20.0%~ 120.0%	100.0%	X	5-40
b05	Electronic thermal characteristic, selection	0 – Cooling fan is mounted on the motor shaft (Self-cool) 1 – Cooling fan is powered by external source (Forced-cool)	1	X	
Overload Restriction					
b06	Overload Restriction mode selection	0 – Disable 1 – Enable (Current Frequency) 2 – Enable (b08) 3 – Enable (Max 20% of F02 value) * Overvoltage limit mode : function code b67	1	X.	5-41
b07	Overload restriction level setting (constant speed)	0 – disable 1 – enable (current frequency) 2 – enable (b08) 3 – enable (max 20% of F02 value) * Overvoltage limit mode: function code b67	HD:180% ND:150%	X	
b08	Overload restriction constant setting	0.1~10.0 [sec]	10.0 sec	X	

(Note 6) Allowable instantaneous power failure time is depending on machine or load conditions, So, please check and verification test before using.

Func-code	Name	Range	Defaults	Runtime edit	Page
Others					
b09	Software lock mode selection	0 – All parameters locked (Except b09, when SFT from terminal is on) 1 – All parameters locked (Except b09 and F01, when SFT from terminal is ON) 2 – All parameters locked (Except b09, when function set) 3 – All parameters locked (Except b09 and F01, when function set) 4 – All parameters locked (Except b09, F01, F02, F03, when function set)	0	X	5-42
b10	Start frequency Adjustment	0.50~ Max. frequency(A04) [Hz]	0.50Hz	X	5-42
b11	Carrier frequency setting	0.75~16.0[kHz] (0.4kW~3.7kW) 0.75~10.0[kHz] (5.5kW~22kW)	HD:5.0kHz ND:2.0kHz	O	5-42
b12	Initialization mode	0 – Trip history clear 1 – Parameter initialization	0	X	5-42
b13	Country code for initialization	0 – Korean version 1 – Europe version 2 – US version	0	X	5-42
b14	RPM conversion factor setting	0.01~99.99	1.00	O	5-42
b15	STOP key validity during terminal operation	0 – STOP enable 1 – STOP disable	0	X	5-42
b16	Resume on FRS cancellation mode	0 – Restart from 0Hz 1 – Restart from frequency detected from real speed of motor	0	X	5-42
b17	Communication number	1~32 [count]	1	X	5-43
b18	Ground fault setting (Note7)	0.0~100.0 [%] 0 – Do not detect ground fault.	0.0%	X	5-43

(Note 7) Below 22kW, disable ground fault setting. (value is always 0)
Upper 30kW, able to use as above range.

Func-code	Name	Range	Defaults	Runtime edit	Page
b19	Speed Search Delay Time	0.1~30.0[sec]	2.0 sec	O	5-43
b20	Voltage increase Time during Speed Search	0.1~10.0[sec]	1.0 sec	O	
b21	Current limit level for Speed search	50.0~180.0[%]	100.0 %	O	
b23	Frequency match operation selection	0 – 0Hz Starting operation 1 – Frequency matching & start operation	0	O	5-43
b24	Failure status output selection by relay in case of failure	0 – Inactive at low voltage failure 1 – Active at voltage failure (Inactive at restart mode) 2 – Active of all failure occurred 3 – Active at voltage failure (For low voltage failure, automatic restart)	0	O	5-44
b25	Stop method selection	0 – Decelerating stop 1 – Free run stop	0	O	5-47
b26	Inverter type change to P-type (Normal Duty)	0 – Heavy Duty (Standard Type) (Note8) 1 – Normal Duty (P-Type)	0	X	5-47
b27	Input phase loss	0~30 [sec] 0 – Disable	10 sec	O	5-47
b28	Communication time out setting	0~60 [sec] 0 – Disable	0 sec	O	5-47
b29	Communication time out operation mode	0 – Always active 1 – Active in case of inverter is running	0	O	
b30	Display code setting	1~13	1	O	5-47
b31	2 nd communication channel 485 communication speed setting	1 – 2400 [bps] 2 – 4800 [bps] 3 – 9600 [bps] 4 – 19200 [bps] 5 – 38400 [bps]	3	O	5-47

(Note 8) Below 3.7kW, value is always 0
Upper 5.5kW, able to use as above range.

Func-code	Name	Range	Defaults	Runtime edit	Page
BRD (Dynamic braking) Function					
b32	BRD selection	0 – Disable 1 – Enable only during inverter running 2 – Enable	1	X	5-48
b33	BRD using ratio	0~10 [%] (0.4kW~3.7kW) 0~50 [%] (5.5kW~22kW)	10%	X	5-48
Overvoltage Suppression (OVS) Function					
b34	Maximum OVS output frequency	0.00~300.0 [Hz]	20.00Hz	O	5-48
b35	OVS P gain	0~100.0 [%]	10.00%	O	
b36	OVS I gain	0~100.0 [%]	1.00%	O	
b37	OVS D gain	0~100.0 [%]	1.00%	O	
b38	Q axis reference	-100.0~100.0	0.0	O	
b39	Filter bandwidth	0~1000	1	O	
b40	Overvoltage suppression	0 – Disable 1 – Enable for current 2 – Enable for voltage	0	O	
b41	Limit Time	0.0~100.0 [sec]	0.5 sec	O	
DC Injection Braking					
b42	VFD start delay time after DC Injection braking	0.0~60.0 [sec]	0.0 sec	X	5-54
b43	DC Injection braking time at start	0.0~6000.0[sec]	0.0 sec	O	
b44	Current controller P gain in DC braking	0.01~100.00 [%]	5.00%	O	
b45	Current controller I Gain time in DC braking	0~100.00 [%]	5.00%	O	
b46	DC Injection braking force	0.0~100.0[%] of inverter rated current	50.0%	O	
Overload Restriction					
b49	Overload restriction level at acceleration & deceleration	HD: 20.0%~ 200.0% ND: 20.0%~ 165.0%	HD:180% ND:150%	X	5-54

Func-code	Name	Range	Defaults	Runtime edit	Page
Droop Control function					
b50	Droop control start freq.	0.00 ~ Max. frequency (A04) [Hz]	0.00Hz	O	5-55
b51	Droop control standard freq.	10.00 ~ Max. frequency (A04) [Hz]	60.00Hz	O	
b52	Droop control gain	0.00~50.00 [%]	5.00%	O	
b53	Droop star torque	0.0~100.0 [%]	0.0%	O	
b54	Droop acceleration time	1.0~100.0 [sec]	20sec	O	
b55	Droop control mode	0 – Disable 1 – Enable	0	O	
Motor Load Detection Function					
b56	Motor load detection selection	0 – Disable 1 – Overload detection 2 – Underload detection 3 – Overload/Underload detection 4 – Overload detection with fault (E23) 5 – Underload detection with fault (E24) 6 – Overload/Underload detection with fault (E23, E24)	0	X	5-57
b57	Motor overload detection level	20.0~200.0 [%] of motor rated current	100.0%	X	
b58	Motor underload detection level	20.0~200.0 [%] of motor rated current	100.0%	X	
b59	Overload/Underload detection time	0.0~60.0 [sec]	10.0sec	X	5-58
b60	Overload/Underload detection safe zone	0.00 ~ Max. frequency (A04) [Hz]	0.00Hz	X	
Dwell Function					
b61	Dwell frequency at start	0.00 ~ Max. frequency (A04) [Hz]	0.00Hz	O	5-58
b62	Dwell time at start	0.0~10.0 [sec]	0.0sec	O	
b63	Dwell frequency at stop	0.00 ~ Max. frequency (A04) [Hz]	0.00Hz	O	
b64	Dwell time at stop	0.0~10.0 [sec]	0.0sec	O	

Func-code	Name	Range	Defaults	Runtime edit	Page
KEB Function					
b65	KEB operation selection	0 - Disable 1 - Enable (b66 setting value) 2 - Enable (DC link voltage control)	0	X	5-59
b66	KEB control gain	0.1~100.0[%]	10.0%	X	
Overvoltage Limit(Deceleration Only) & Hold Function					
b67	Overvoltage Limit setting	0 – Disable 1 – Enable	1	X	5-59
b68	Hold time at running	0.0~60.0 [sec]	0.0sec	O	5-59
b69	Stop frequency setting	0.00 ~ Max. frequency (A04) [Hz]	0.00Hz	O	5-59
b70	Hold time at stop	0.0~60.0 [sec]	0.0sec	O	5-59
Display Function					
b71	User parameter setting	1 – Output frequency monitor 2 – Output current monitor 3 – Output voltage monitor 4 – Rotation direction monitor 5 – PID feedback monitor 6 – Intelligent terminal input monitor 7 – Intelligent terminal output monitor 8 – RPM monitor 9 – Power consumption monitor 10 – Display of cumulative time (day) 11 – Display of cumulative time (minute) 12 – DC link voltage	1	O	5-60
b72	User mathematical sign	0 – '+' calculation 1 – '-' calculation 2 – 'X' calculation 3 – '/' calculation	0	O	
b73	Define user setting	1.00~600.00	1.00	O	

5.1.6 Extended function C mode (C group)

Table 5-6 Extended function C mode (C group)

Func-code	Name	Range	Defaults	Runtime edit	Page
Input Terminal and Related Function					
C01	Intelligent input terminal 1 setting	0 – FW (Forward run command) 1 – RV (Reverse run command) 2 – CF1 (1 st multi speed command) 3 – CF2 (2 nd multi speed command) 4 – CF3 (3 rd multi speed command) 5 – CF4 (4th multi speed command)	0	X	5-61
C02	Intelligent input terminal 2 setting	6 – JG (Jogging operation command) 8 – 2CH (2 stage accel/decel command) 9 – FRS (Free run stop command) 10 – EXT (External trip) 11 – USP (Unattended Start Protection)	1	X	
C03	Intelligent input terminal 3 setting	12 – SFT (Software lock) 13 – AT (Analog input current/voltage selection signal) 14 – RS (Reset) 15 – STA (Start)	2	X	
C04	Intelligent input terminal 4 setting	16 – STP (Keep) 17 – F/R (Forward/Reverse) 18 – UP (Remote control UP) 19 – DOWN (Remote control DOWN) 20 – O/R (Local keypad operation) 21 – T/R (Local terminal input operation)	3	X	
C05	Intelligent input terminal 5 setting	22 – PIDIR (PID Integral reset) 23 – PIDD (PID Disable) 24 – Add A11 to setting frequency(F.O) 25 – Cancel add A11(R.O) 26 – EXT2 (External trip2)	13	X	
C06	Intelligent input terminal 6 setting	27 – EXT3 (External trip3) 28 – EXT4 (External trip4) 29 – EXT5 (External trip5) 30 – EXT6 (External trip6) 31 – Up/Down Value Clear	14	X	

Func-code	Name	Range	Defaults	Runtime edit	Page
Input Terminal Status					
C07	Input terminal 1 a/b contact setting (NO/NC)	0 – a contact (Normal open) [NO] 1 – b contact (Normal close) [NC]	0	X	5-61
C08	Input terminal 2 a/b contact setting (NO/NC)		0	X	
C09	Input terminal 3 a/b contact setting (NO/NC)		0	X	
C10	Input terminal 4 a/b contact setting (NO/NC)		0	X	
C11	Input terminal 5 a/b contact setting (NO/NC)		0	X	
C12	Input terminal 6 a/b contact setting (NO/NC)		0	X	
Output Terminal and Related Function					
C13	Replay output(30A/30B/30C) terminal setting	0 – RUN (Run signal) 1 – FA1 (Frequency command arrival) 2 – FA2 (Setting frequency or more) 3 – OL (Overload advance notice)	5	X	5-71
C14	Open collector output (11-CM2) terminal setting	4 – OD (Output deviation for PID) 5 – AL (Alarm signal) 6 – MO (Modbus communication)	1	X	5-72
C15	Open collector output (12-CM2) terminal setting	7 – SOL (System Overload) 8 – SUL (System Underload) 9 – SOL/SUL (System Overload/Underload detection) 10 – AI_LOSS(Analog Input loss detection) 11 – KEY_LOSS(keypad loss detection) 12 – BRK(Control external braking)	0	X	
C16	Output terminal 11 - CM2 a/b contact setting	0 – a contact (Normal open) [NO] 1 – b contact (Normal close) [NC]	0	X	
C17	Output terminal 12 - CM2 a/b contact setting		0	X	
C18	FM output selection	0 – Output frequency monitor 1 – Output current monitor 2 – Output voltage monitor 3 – Output electric power monitor 4 – Output torque monitor 5 – Control by Modbus communication 6 – DC voltage	0	X	5-78
C19	FM gain adjustment	0~250.0 [%]	100.0%	○	5-79
C20	FM offset adjustment	-3.0~10.0 [%]	0.0%	○	

Func-code	Name	Range	Defaults	Runtime edit	Page
C21	Overload advance notice signal level setting	10.0~200.0 [%] of rated current	100.0%	X	5-79
C22	Acceleration arrival signal frequency setting	0.00~Max. frequency (A04) [Hz]	0.00Hz	X	5-79
C23	Deceleration arrival signal frequency setting	0.00~Max. frequency (A04) [Hz]	0.00Hz	X	
C24	PID deviation level setting	0.0~100.0 [%]	10.0%	X	5-79
C25	AMI output selection	0 – Output frequency monitor 1 – Output current monitor 2 – Output voltage monitor 3 – Output electric power monitor 4 – Output torque monitor 5 – Control by Modbus communication 6 – DC voltage	1	X	5-79
C26	AMI gain adjustment	0 ~ 250.0%	100.0%	O	5-80
C27	AMI offset adjustment	-99.9 ~ 100.0%	0.0%	O	
Up/Down Function					
C28	UP/Down value saving selection	0 – Disable 1 – Enable	0	X	5-68
C29	Up/Down initial value setting	0 ~ Max. frequency [A04]	0.00Hz	O	
C30	Up/Down Acc/decel time setting	0.1~3000.0[sec]	10.0sec	O	
C31	Up/Down function selection	0 – Disable 1 – Enable	0	X	
C32	Up/Down value setting	0.00~ Max. frequency [A04]	0	O	
Keypad/Communication fault					
C33	Decel time at fault occur	0.0~6000.0[sec]	10.0sec	O	5-77
C34	Selection of running state when keypad connection failed	0 – Run 1 – Stop	0	X	
C35	Selection of keypad detection	0 – Disable 1 – Abnormal move detection 2 – Detect keypad fault and occur E61 3 – Detect abnormal move and occur E61	0	O	

Func-code	Name	Range	Defaults	Runtime edit	Page
C36	Selection of communication or analog speed command failure detection	0 – Disable 1 – Loss frequency (50%) (Less than 50% of A07) 2 – Loss frequency (100%) (Under than A07) 3 – Loss frequency when speed command by RS485	0	O	5-76
C37	Selection of run command when speed losing	0 – Disable 1 – Free run stop (Output block) 2 – Stop 3 – Run by C38 frequency	0	O	
C38	Waiting time in case of frequency command loss	0.0~120.0[sec]	1.0sec	O	
C39	Frequency setting in case of analog command loss	0.00 ~ Max. frequency [A04]	30.00Hz	O	
Overload Caution Time					
C40	Overload caution time	Detection time of overload advance notice signal level (C21) 0.0~30.0[sec]	10.0sec	O	5-74
External Brake Function					
C41	Current of external brake	0.0~200.0 [%] of rated current	100.0%	O	5-77
C42	Frequency of external brake	0.00 ~ 25.00[Hz]	10.00Hz	X	
C43	Timer of external brake	0.0 ~ 5.0[sec]	1.0sec	O	
C44	Stop frequency of external brake	0.00 ~ 25.00[Hz]	10.00Hz	X	
C45	Stop timer of external brake	0.0 ~ 5.0[sec]	1.0sec	O	
Changed Parameter Check Function					
C46	Changed Parameter Check	0 - No display 1 - Display changed function code lists	0	O	

5.1.7 Motor (H group)

Table 5-7 Motor setting (H group)

Func-code	Name	Runtime edit	Range	Default
H01	Auto-tuning mode selection	X	0 – Auto-tuning OFF 1 – Auto-tuning ON	0
H02	Motor data selection	X	0 – Standard motor data 1 – Use auto-tuning data	0
H03	Motor capacity	X	0 – MOT_004LF 1 – MOT_007LF 2 – MOT_015LF 3 – MOT_022LF 4 – MOT_037LF 5 – MOT_055LF 6 – MOT_075LF 7 – MOT_110LF 8 – MOT_150LF 9 – MOT_185LF 12 – MOT_004HF 13 – MOT_007HF 14 – MOT_015HF 15 – MOT_022HF 16 – MOT_037HF 17 – MOT_055HF 18 – MOT_075HF 19 – MOT_110HF 20 – MOT_150HF 21 – MOT_185HF 22 – MOT_220HF 23 – MOT_300HF	-
H04	Motor poles setting	X	2~48[P]	4
H05	Motor rated current	X	Range is 0.1 – 800.0 [A]	-
H06	Motor no-load current (I ₀)	X	Range is 0.1 – 400.0 [A]	-
H07	Motor rated slip	X	Range is 0.01 – 20.0 [Hz]	-
H08	Motor Resistance R1	X	Range is 0.1 - 3000 [mΩ]	-
H09	Transient Inductance	X	Range is 0.001 – 30.00 [mH]	-
H10	Motor ResistanceR1	X	Range is 0.1 - 3000 [mΩ]	-
H11	Transient Inductance auto tuning data	X	Range is 0.001 – 30.00 [mH]	-
H12	State of Auto-tuning	O	0:AT_READY 1:AT_RSTUNE 2:AT_LSIGMATUNE 3:AT_TRTUNE 4:AT_LSTUNE 5:AT_ENDING 6:AT_ENDAT	0

5.2 d Group Parameters

- **d01 Output Frequency Monitor**
 - Range: 0.00 ~ 400.00 Hz

Real time display of output frequency of the VFD
- **d02 Output Current Monitor**
 - Range: 0.0 ~ 9999 Amps

Real time display of output current of the VFD
- **d03 Output Voltage Monitor**
 - Range: 0 ~ VFD rated voltage

Real time display of output voltage of the VFD
- **d04 Rotation Direction**
 - F: Forward Run
 - □: Stop
 - r: Reverse Run

Real time display of rotation of the VFD
- **d05 PID Feedback**
 - Range: 0.00 ~ 100.0 %

Scaled PID process variable – feedback value
- **d06 Intelligent Input Terminal Status**
 - Show the Intelligent Input Terminal Status

Meaning: T1 is On, T2 is Off
T3 is On, T4 is Off
T5 is On, T6 is Off
- **d07 Intelligent Output Terminal Status**
 - Show the Intelligent Output Terminal Status

Meaning: RN0 – 1 is On
RN2 – 3 is On
AL0 – AL1 is On
- **d08 RPM Output**
 - Range: 0 ~ 65,540 RPM

Scaled RPM Output determined by equation: $(120 * d01 * b14) / H04$
- **d09 Power Consumption**
 - Range: 0 ~ 999.9 kW
- **d10 VFD Runtime (Hours)**
 - Range: 0 ~ 9999 Hr

Accumulated VFD runtime in hours

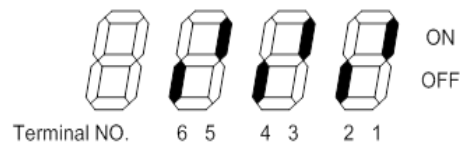

- **d11 VFD Runtime (Minutes)**

- Range: 0 ~ 59 Min

Accumulated VFD runtime in minutes

*** Total run time is a combination of d10 and d11.

- **d12 DC Bus Voltage**

- Range: 0 ~ 999 V

Real time voltage on DC bus.

- **d13 Current Fault**

When fault occurs, the VFD automatically displays this parameter.

Additional information of the fault can be accessed by using up arrow key.

Fault Code

- Press the UP key
 - Output frequency at time of fault
- Press the UP key
 - Output current at time of fault
- Press the UP key
 - DC bus voltage at time of fault
- Press the FUNC key
 - Back to d13 display

- **d14 Previous Fault 1**

Displays last fault that occurred. Additional information can be accessed as shown above in d13.

- **d15 Previous Fault 2**

Displays Fault 2 that occurred. Additional information can be accessed as shown above in d13.

- **d16 Previous Fault 3**

Displays Fault 3 that occurred. Additional information can be accessed as shown above in d13.

- **d17 Fault Count**

Displays accumulated fault count.

- **d18 Inverter S/W version**

Displays software version of inverter.

- **d19 Fan operation time(day)**

Displays fan accumulation time (day).

- **d20 Fan operation time(minute)**

Displays fan accumulation time (minute).

- **d21 Inverter internal temperature(°C)**
Display Inverter internal temperature (°C)

5.3 F Group Parameters

F group holds very basic frequency related parameter values to operate the iMaster C1 VFD.

- **F01 Output frequency setting**
 - Range: 0.00 ~ 400.00 Hz in 0.01 Hz
 - Range: 0.00 ~ 300.00 Hz in 0.01 Hz for Sensor-less Vector Control (A31=2)

This parameter displays the frequency setpoint for the VFD.
VFD Frequency can be controlled by various sources set in A01.

- If A01=0: Use the Volume Key on the panel
- If A01=1: Use the Terminal (O-L, OI-L)
- If A01=2: Use Up/Down Keys
- If A01=3: Use Control Terminal Input (RJ45)
(Except 300LF~750LF)
- If A01=4: Use Control Terminal Input,(RXP-RXN)
- if A01=5: Fieldbus (option)
- if A01=6: Potentiometer and remote

❖ Related Parameters: A01

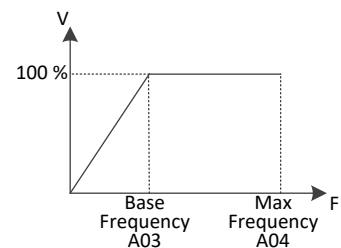

- **F02 Acceleration time 1 setting**
 - Range: 0.1 ~ 999.9 Sec in 0.1 Sec
 - 1000 ~ 6000 Sec in 1 Sec

Acceleration time from 0Hz to Maximum Frequency (A04)

❖ Related Parameters: A54, A56, A57, A59

- **F03 Deceleration time 1 setting**
 - Range: 0.1 ~ 999.9 Sec in 0.1 Sec
 - 1000 ~ 6000 Sec in 1 Sec

Deceleration time from Maximum Frequency (A04) to 0Hz

❖ Related Parameters: A55, A56, A58, A60

- **F04 Rotation direction setting**
 - 0: Forward Run
 - 1: Reverse Run

Sets the direction of VFD to forward or reverse at keypad operation only

❖ Related Parameters: A02

- **F05 Rotation direction selection**
 - 0: Enable both way (FW and RV)
 - 1: Disable forward
 - 2: Disable reverse

Sets allow or prohibit forward/reverse rotation.

- **F06 Define custom display**
 - Range: 0 ~ 65535 in 1

Display various parameters.

❖ Related Parameters: B71~B73

5.4 A Group Parameters

A group holds extended frequency control Parameters and VFD operational Parameters.

- **A01 Frequency command (Multi-speed command method)**

- 0: Keypad potentiometer
- 1: Control terminal input (O-L: Voltage, OI-L: Current)
- 2: Standard operator
- 3: Remote Operator 1 (1st communication -RJ45)
- 4: Remote Operator 2 (2nd communication - terminal)
- 5: Fieldbus (option)
- 6: Potentiometer and remote

Determined the source of the frequency command.

- ❖ Related Parameters: F01, A05~A10, A61~A64, b17, b28~b29, b31

- **A02 Run command**

- 0: Run/Stop Key on keypads
- 1: Control Terminal Input ((FW, RV Connect)
- 2: Remote Operator 1 (RJ45 Port, RS485 Communication), Except 300LF~750LF
- 3: Remote Operator 2 (RXP-RXN, RS485 Communication)
- 4: Fieldbus (option)

Determined the source of the run command.

- ❖ Related Parameters: F04, d06, C1~C12, b17, b28~b29, b31

- **A03 Base frequency setting**

- Range: 0.00 ~ Maximum Frequency(A04) in 0.01 Hz

Frequency at which the maximum voltage is reached. Should be set to the motor rated frequency.

- ❖ Related Parameters: None

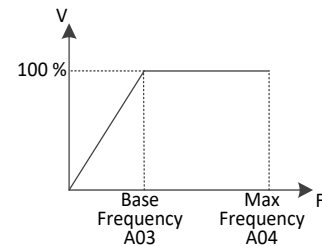

- **A04 Maximum Frequency setting**

- Range: A03 ~ 400.00 Hz in 0.01 Hz
- If Sensorless Vector Control (A31=2): Base Frequency (A03) ~ 300 Hz in 0.01 Hz

Maximum frequency the VFD will output.

- ❖ Related Parameters: F02, F03

- **A05 External frequency setting start (O, OI)**

- Range: 0.00 ~ Maximum Frequency(A04) in 0.01 Hz

When Frequency Command Source is set to the terminal input (A01=1), this parameter determines the Frequency Setpoint (F01) at minimum analog input current, 4mA (or voltage, 0 V)

- ❖ Related Parameters: A01, A07

- **A06 External frequency setting end (O, OI)**

- Range: 0.00 ~ Maximum Frequency(A04) in 0.01 Hz

When Frequency Command Source is set to the terminal input (A01=1), this parameter determines the Frequency Setpoint (F01) at maximum analog input current, 20mA (or voltage, 10 V)

- ❖ Related Parameters: A01, A08

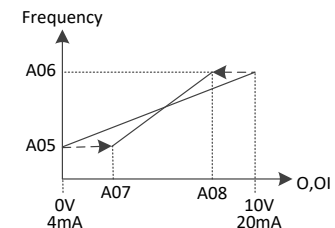

- **A07 External frequency start rate setting(O, OI)**

- Range: 0.0 ~ 100.0 % in 0.1 %

Offsets the minimum analog input reference corresponding to A05.

Example: if set to 10%, minimum analog current value becomes 5.6mA (or 1 V).

- ❖ Related Parameters: A01, A05, A09

- **A08 External frequency end rate setting(O, OI)**

- Range: 0.00 ~ 100.0 % in 0.1 %

Offsets the maximum analog input reference corresponding to A06.

Example: if set to 90%, maximum analog current value becomes 18.4mA (or 9V).
For any reference above A08, VFD holds the value in A06.

- ❖ Related Parameters: A01, A06

- **A09 External frequency start pattern setting**

- 0: Start at start frequency (A05)
- 1: Start at 0 Hz

Determines the Frequency Setpoint (F01) for any analog reference below A05.

- ❖ Related Parameters: F01, A05, A07

- **A10 External frequency sampling setting**

- Range: 0.1~500.0

Filter on analog input to help reduce noise on signal.

- ❖ Related Parameters: None

- **A11~A25 Multi-speed frequency setting**

- Range: 0.01 ~ Max Frequency (A04)

Programming 15 different frequency values to Parameters, A11~A25: and select by a combination of 4 terminal inputs, CF4~CF1, will further discuss in C group.

For HVAC system, often multiple heating temperature setting is desired.

For instance,
 @ 7 am, set to 65 °F,
 @ 12 pm, set to 68 °F
 @ 3 pm, set to 70 °F
 @ 6 pm, set to 72 °F
 @ 9 pm, set to 75 °F, etc.

- ❖ Related Parameters: F01, C01~C12

Programming Example:

- A02 = 1; run by keypad (or A02=2; by Terminal)
- F01 = Frequency Number @ CF4:CF1 = 0000
- C01 ~ C05 (Assign to FW, Multi Frequency Pointers)
- C07 ~ C12 (Assign Close/Open Polarity)
- A11 ~ A25 (Frequency Values)

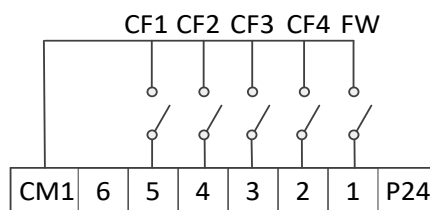

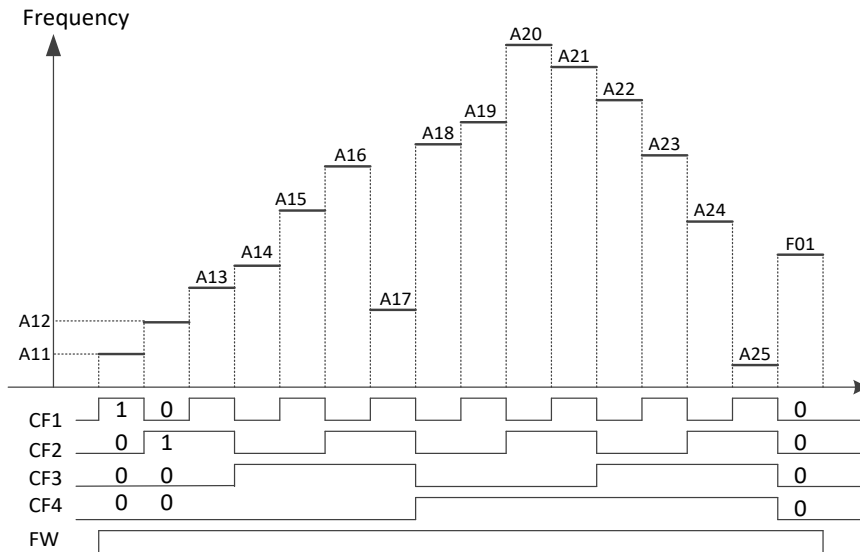

- **A26 Jog frequency setting**
 - Range: 0.50 ~ 10.00 Hz in 0.01 Hz

Jogging frequency is used to move/rotate the motor in small increment at low frequency. It is selected using input terminal.

❖ Related Parameters: C01~ C12

- **A27 Jog stop operation selection**
 - 0: Free Run to Stop (Coast to Stop)
 - 1: Deceleration to Stop
 - 2: DC Injection Braking to Stop

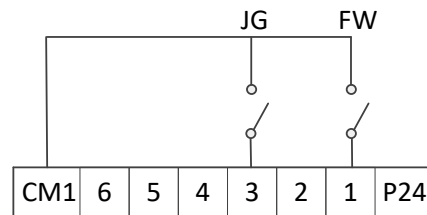

Jogging frequency is used to move/rotate the motor in small increment at low frequency. It is selected using input terminal.

❖ Related Parameters: C01~C12

Programing Example:

- A02 = 1; run by keypad (or A02=2; by Terminal)
- F01 = Frequency Number @ CF4:CF1 = 0000
- C01 ~ C05 (Assign to FW, JOG)
- C07 ~ C12 (Assign Close/Open Polarity)
- A11 ~ A25 (Frequency Values)

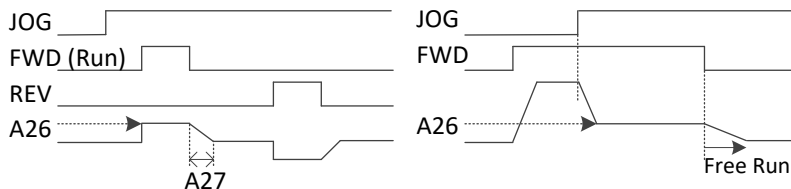

- **A28 Torque boost mode selection**
 - 0: Manual Torque Boost (A29, A30)
 - 1: Automatic Torque Boost (H02)

Select a torque boost mode. For V/F Control, compensate a beginning torque by increasing the output voltage.

If selected Automatic Torque Boost mode, recommended the following

1. Run "Auto Tuning"
 2. Use an auto tuning data(H02=1)
- ❖ Related Parameters: H1~H11

- **A29 Manual torque boost setting(forward)**

- Range: 0.0 ~ 50.0 % in 0.1 %

For Manual Torque Boost mode, program the value in % of an output voltage.

❖ Related Parameters: A30

- **A30 Manual torque boost Frequency setting (forward)**

- Range: 0.0 ~ 100.0 % in 0.1 %

Program the frequency breakpoint

❖ Related Parameters: A29

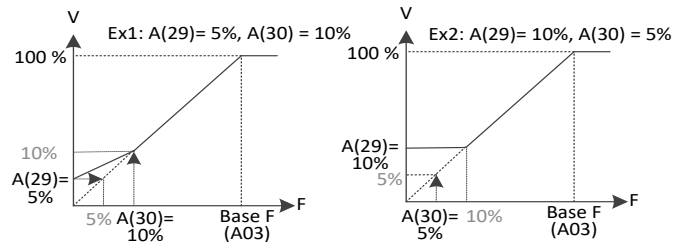

- **A31 V/F characteristic curve selection**

- 0: Constant Torque
- 1: Reduced Torque (Variable Torque)
- 2: Sensorless Vector Control
- 3: VF_USER

Reduced torque is effective for fan or pump application which do not require high torque at low frequency. By reducing the output voltage, increased efficiency, lower noise, and lower vibration.

For Sensorless Vector method, per specified output voltage, current, motor parameters, motor rpm, the corresponding torque value is calculated. At very low frequency up to 0.5 Hz, high torque operation is possible

❖ Related Parameters: A29~A30, H01~H11

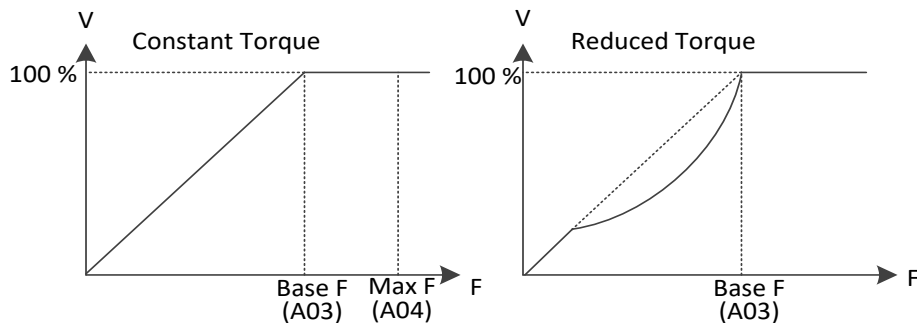

For VF_USER method, V / F ratio required for special motors can be set arbitrarily.

❖ Related Parameters: A86 ~ A93

- **A32 V/F gain setting**

- Range: 20.0 ~ 110.0 % in 0.1 %

The output voltage cannot exceed the input voltage

❖ Related Parameters: A53, A03

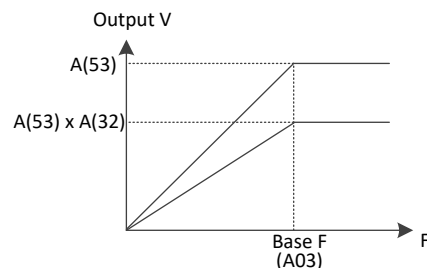

- **A33 DC injection braking function selection**

- 0: Disabled
- 1: Enabled

Enable or Disable DC Injection Braking Function
By adding the force to the rotor, slowing the motor to stop.
❖ Related Parameters: A33~A37

- **A34 DC injection braking frequency setting**

- Range: 0.50 ~ 10.00 Hz in 0.01 Hz

Program the VFD frequency out when DC injection braking function kicks in. If set A34 to 0.5Hz, when VFD frequency out reaches to 0.5 Hz, DC braking function is activated.
❖ Related Parameters: A33~A37

- **A35 DC injection braking output delay time setting**

- Range: 0.0 ~ 5.0 Sec in 0.1 Sec

Program the delay time when the DC braking function actually starts form when VFD out is the frequency value in A34.
❖ Related Parameters: A33~A37

- **A36 DC injection braking force setting**

- Range: 0.0 ~ 100.0 % in 0.1 %

- **A37 DC injection braking time setting**

- Range: 0.0 ~ 10.0 Sec in 0.1 Sec

Program the DC injection braking duration
❖ Related Parameters: A33~A37

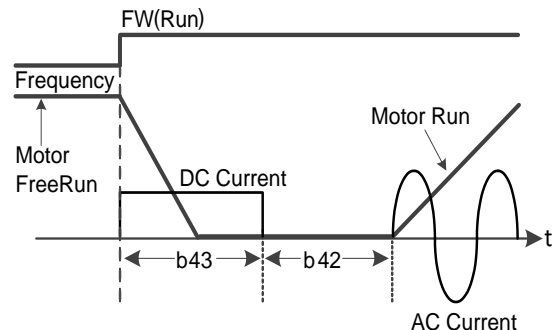
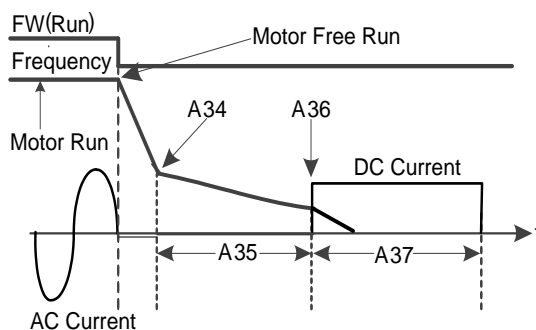

b42 ~ b46 (Extended A33 ~ A37)

***Note: For independent DC injection braking function control at VFD start and at VFD stop, additional parameters are allocated at b42 ~ b46, listed here for continuity, repeated again in the b Group descriptions.

- **b42 VFD start delay time after DC injection braking**

- Range: 0.0 ~ 60.0 Sec in 0.1 Sec

Program the VFD start delay time after braking time at start is done
❖ Related Parameters: A33, b42~b46

- **b43 DC injection braking time at start**
 - Range: 0.0 ~ 6000.0 Sec in 0.1 Sec

Program the DC Injection Braking duration before VFD start

 - ❖ Related Parameters: A33, b42~b46

 - **b44 Current controller P Gain in DC braking**
 - Range: 0.01 ~ 100.00 % in 0.01 %

Program the current controller P gain in DC braking

 - This value is applied both brake modes (start and stop)
 - If motor speed has a large overshoot at DC braking, decrease this value
 - If value is too big, motor can be vibrated or can't be stopped
 - ❖ Related Parameters: A33, b42~b46

 - **b45 Current controller I Gain in DC braking**
 - Range: 0.0 ~ 100.00 Sec in 0.01 Sec

Program the current controller I gain in DC braking

 - This value is applied both brake modes (start and stop)
 - If motor is vibrated or not stop at DC braking, decreased this value
 - If value is too big, DC braking force can be weak
 - ❖ Related Parameters: A33, b42~b46

 - **b46 DC injection braking force**
 - Range: 0.0 ~ 100.0 % in 0.1 %

Program the level of DC injection braking force of rated electric power of iMaster C1

 - ❖ Related Parameters:

 - **A38 Frequency upper limit**

If 0 disable Frequency Limit Function

 - Range: Frequency Lower Limit(A39) ~ Max Frequency(A04) in 0.01 Hz

Program upper limit of an output frequency

 - ❖ Related Parameters:

 - **A39 Frequency lower limit**
 - Range: 0.00 ~ A38 Hz in 0.01 Hz

Program lower limit

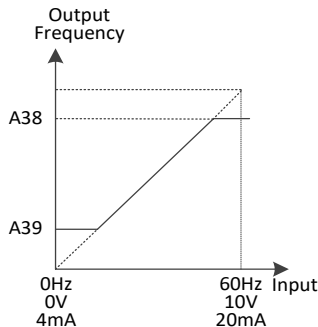
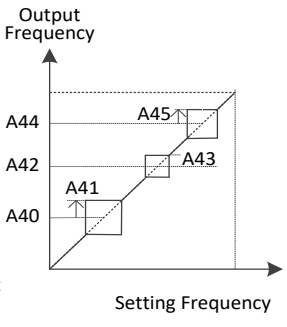
 - ❖ Related Parameters:
- 

- **A40, 42, 44 Jump(center) frequency setting**
 - Range: 0.00 ~ Max Frequency(A04) Hz in 0.01 Hz

Program 3 output frequency values to mitigate different resonance points at which vibration can cause damages to the equipment such as fans or pumps.

 - ❖ Related Parameters: A41, A43, A45

- **A41, 43, 45 Jump(hysteresis) frequency setting**

- Range: 0.00 ~ 10.00 Hz in 0.01 Hz

Program skip frequency ranges for A40, A42, and A44 respectively.

❖ Related Parameters:

- **A46 Manual torque boost(Reverse)**

- Range: 0.0 ~ 50.0 % in 0.1 %

For Manual Torque Boost mode, program the value in % of an output voltage.

❖ Related Parameters: A47

- **A47 Manual torque Frequency setting (Reverse)**

- Range: 0.0 ~ 100.0 % in 0.1 %

Program the frequency breakpoint

❖ Related Parameters: A46

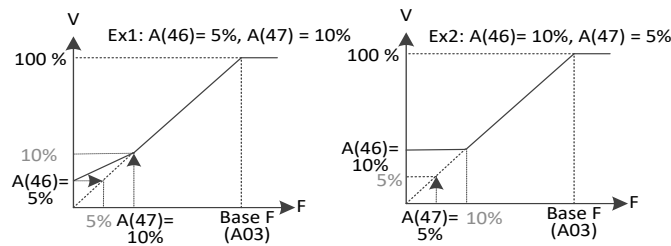

- **A48 Auto torque boost gain setting**

- Range: x0.00 ~ x2.50 in x0.01

In case the user set function code A28 to 1, it's possible to set the auto torque boost voltage gain at function code A48. Too low value may result in insufficient torque at start-up and too high value may cause overload.

- **A49 Auto torque boost filter time constant**

- Range: 0.1 ~ 999.9 mSec in 0.1 mSec

In case the user set function code A28 to 1, it's possible to set the auto torque boost filter time constant at function code A49.

- **A52 AVR function selection**

- 0: Constant ON
- 1: Constant OFF
- 2: OFF During Deceleration (On otherwise)

AVR enables the constant output regardless input power fluctuation.

❖ Related Parameters:

- **A53 Motor input voltage setting**

- 200V Class Setting: 80V ~ 240V for LF Models
- 400V Class Setting: 160V ~ 500V for HF Models
- Default :
 - SF/LF/LFP : 220V / HF/HFP : 380V
 - Korea : 220/380
 - Europe : 230/400
 - USA : 230/460

User can set the motor income voltage at function code A53. (however, inverter only output the income voltage)

- **A54 Second acceleration time setting**

- Range: 0.1 ~ 999.9 Sec in 0.1 Sec
- Range: 1000 ~ 6000 Sec in 1.0 Sec

In addition to Acceleration Time 1 in F02, Second acceleration time can be specified. Its value can also be entered by input terminal 2CH

❖ Related Parameters:

- **A55 Second deceleration time setting**

- Range: 0.1 ~ 999.9 Sec in 0.1 Sec
- Range: 1000 ~ 6000 Sec in 1.0 Sec

In addition to deceleration Time 1 in F03, Second acceleration time can be specified. Its value can also be entered by input terminal 2CH

❖ Related Parameters:

- **A56 Two stage acc1/dece1 switching method selection**

- 0: 2CH input from terminal
- 1: Parameters (A54,A55, A57,A58)

Select the transition frequency point about acceleration/deceleration by input terminal or frequency

❖ Related Parameters: C01~C12, A57~A60

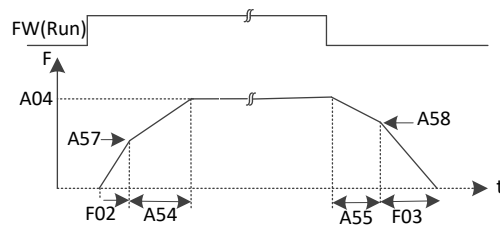

- **A57 Acc1 to Acc2 frequency transition point**

- Range: 0.00 ~ Max Frequency(A04) in 0.01Hz

In addition to Acceleration Time 1 in F02, Acceleration Time 2 can be specified. Its value can also be entered by input terminal 2CH

❖ Related Parameters:

- **A58 Decel 1 to Decel 2 frequency transition point**

- Range: 0.00 ~ Max Frequency(A04) in 0.01Hz

In addition to Deceleration Time 1 in F03, Deceleration Time 2 can be specified. Its value can also be entered by input terminal 2CH

❖ Related Parameters:

- **A59 Acceleration curve select**

- 0: Linear
- 1: S Curve
- 2: U Curve

Select Acceleration Curve Type

❖ Related Parameters:

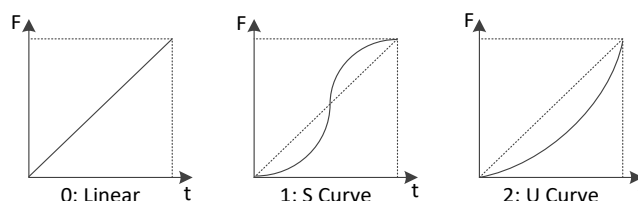

- **A60 Deceleration curve setting**

- 0: Linear
- 1: S Curve
- 2: U Curve

Select Deceleration Curve Type

❖ Related Parameters:

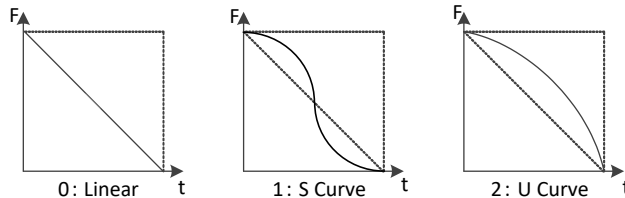

- **A61 Input voltage offset setting**

- Range: -10.0 ~ 10.0 % in 0.1%

Real time editable offset factor for analog input voltage.

❖ Related Parameters: A05~A08

- **A62 Input voltage gain setting**

- Range: 0.0 ~ 200.0 % in 0.1%

Real time editable gain factor for analog input voltage

❖ Related Parameters: A05~A08

- **A63 Input current offset setting**

- Range: -10.0 ~ 10.0 % in 0.1%

Real time editable offset factor for analog input current.

❖ Related Parameters: A05~A08

- **A64 Input current gain setting**

- Range: 0.0 ~ 200.0 % in 0.1%

Real time editable gain factor for analog input current

❖ Related Parameters: A05~A08

- **A65 FAN operation mode**

- 0: Always On
 - Fan always running when the power apply to the inverter
- 1: ON in the run time
 - When the run commend apply to the inverter, FAN is running FAN will be stopped 10minute after stop the inverter. (however, inverter inside temperature is higher than certain level, FAN keeps running)
- 2: ON according to the inverter inside temperature
 - FAN starts running, if the inverter inside temperature is higher than certain level. If the inverter inside temperature become lower than certain level, FAN will stop after 10minute

Select fan operation

❖ Related Parameters: d21

- **A66 S curve start ratio setting of acceleration**
 - Range: 0.0 ~ 100.0 % in 0.1%
 - When S-curve is selected for A59 and A60, the acceleration pattern can be made into a curve.
 - ❖ Related Parameters: A59,A60,A66~A69

- **A67 S curve stop ratio setting of acceleration**
 - Range: 0.0 ~ 100.0 % in 0.1%
 - When S-curve is selected for A59 and A60, the acceleration pattern can be made into a curve.
 - ❖ Related Parameters: A59,A60,A66~A69

- **A68 S curve start ratio setting of deceleration**
 - Range: 0.0 ~ 100.0 % in 0.1%
 - When S-curve is selected for A59 and A60, the deceleration pattern can be made into a curve.
 - ❖ Related Parameters: A59,A60,A66~A69

- **A69 S curve stop ratio setting of deceleration**
 - Range: 0.0 ~ 100.0 % in 0.1%
 - When S-curve is selected for A59 and A60, the deceleration pattern can be made into a curve.
 - ❖ Related Parameters: A59,A60,A66~A69

◆ **A70 ~ A85 Proportional, Integral, Differential (PID) Function**

The PID function enables the system running at the set point automatically by regulating the process using the system feedback, error term. It is used for Cubic Feet of Air it moves per minute (CFM) for fan application, Gallons per minute (GPM) for pump application, pressure control, heating application, etc.

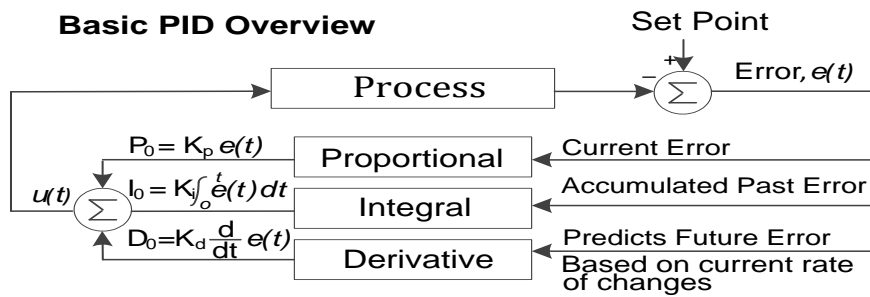

PID Functional Description

- Set Point: Desired System Output Value
- Error: Difference between System output and Set Point
- Proportional (P) Term: Current Error
- Integral (I) Term: Accumulated Past Error
- Derivative (D) Term: Predicted Future Error based on current rate of changes

- **A70 PID function select**
 - 0: PID Control Disabled
 - 1: PID Control Enabled
 - 2: Forward Feed Enabled
 - 3: PID control enable at Stop
 - 4: PID,F/F control enable at Stop

Select PID function type

 - ❖ Related Parameters: A70~A85

- **A71 PID Reference**
 - Range: 0.00 ~ 100.0 % in 0.01 %

PID target value setpoint

 - ❖ Related Parameters: A70~A85

- **A72 PID Reference source**
 - 0: Keypad Potentiometer
 - 1: Control terminal input
 - 2: Standard operator
 - 3: Remote Control (RJ45)
 - 4: Remote operator (Terminal)
 - 5: Option
 - 6: Potentiometer and RJ45

Select PID Setpoint Source

 - ❖ Related Parameters: A70~A85

- **A73 PID Feed-back source**
 - 0: "OI" Current Input (DC 4~20mA)
 - 1: "O" Voltage Input (DC 0~10V)

Select the source how to enter the PID set point in A72.

 - ❖ Related Parameters: A70~A85

- **A74 PID P Gain**
 - Range: 0.1 ~ 1000 % in 0.1 %

Select the PID P gain value

 - It sets the output rate of error between set point value and the feedback value
 - For faster response speed, enlarge the P gain value
 - If P gain is set too large, oscillation or over shooting may occur
 - ❖ Related Parameters: A70~A85

[Input method of target value signal and feedback signal]

Set the reference signal according to the PID reference setting method (A72).

Set the feedback signal according to the PID feedback source (A73)

If A73=0, input terminal being set [AT] has to be ON.

- **A75 PID I Gain Time**
 - Range: 0.0 ~ 3600 Sec in 0.1 Sec

Select the integral time to accumulate PID error value

 - For faster response speed, shorten the accumulate time
 - If I Gain time is set too short, oscillation or over shooting may occur
 - ❖ Related Parameters:

- **A76 PID D Gain Time**
 - Range: 0.0 ~ 10.00 Sec in 0.01 Sec

Program the derivative time for PID function

- For faster response speed, lengthen the D gain time
- If D gain time is set too long, system may become unstable

❖ Related Parameters:

PID Gain Adjustment Example

If the response is not stabilized in a PID control operation, adjust the gains as follows according to the symptom

- The change of controlled variable is slow even when the target value is changed.
 - ⇒ Increase P gain [A74]
- The change of controlled variable is fast, but not stable.
 - ⇒ Decrease P gain[A74]
- It is difficult to make the target value match with the controlled variable.
 - ⇒ Decrease I time [A75]
- Both the target value and the controlled variable are not stable.
 - ⇒ Increase I time[A75]
- The response is slow even when the P gain is increased.
 - ⇒ Increase D time[A76]
- The response is not stabilized due to oscillation even when the P gain is increased.
 - ⇒ Decrease D time[A76]

- **A77 PID Error limit**
 - Range: 0.0 ~ 100.0 % in 0.1 %

Program error limit level, ratio to the maximum error

❖ Related Parameters:

- **A78 PID Output high limit**
 - Range: A79 ~ 100.0 % in 0.1 %

Program the maximum PID output as a percentage of the maximum output frequency

❖ Related Parameters: A04

- **A79 PID Output low limit**
 - 0.00: Disabled the Low Limit
 - Range: -100.0 ~ A78 % in 0.1 %

Program the minimum PID output as a percentage of the maximum output frequency

❖ Related Parameters: A04

- **A80 PID Output Invert**
 - 0: PID Output Invert Disabled
 - 1: PID Output Invert Enabled

Program to enable the PID Output Invert

❖ Related Parameters:

- **A81 PID Scale Factor**
 - Range: 0.1~ 1000 % in 0.1 %

Program the minimum PID output as a percentage of the maximum output frequency(A04)

❖ Related Parameters: A04

- **A82 Pre PID frequency**
 - 0.00: Disabled Pre PID Function
 - Range: 0.00 ~ Max Frequency(A04) in 0.01 Hz

Program the frequency setpoint when PID function is activated. Once the VFD frequency out reaches this value in A82, PID control function is enabled and the VFD is operated in closed loop control.

❖ Related Parameters: A04

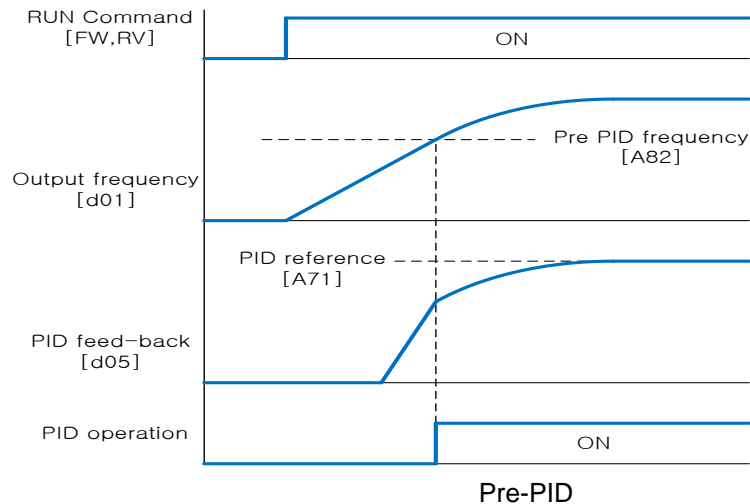

- **A83 Sleep frequency**
 - Range: 0.00 ~ Max Frequency(A04) in 0.01 Hz

Program the frequency setpoint when the VFD goes to Sleep.

❖ Related Parameters:

- **A84 Sleep/wake up delay time**
 - Range: 0.0 ~ 30.0 Sec in 0.1 Sec

Program the delay time when the VFD actually goes to Sleep/Wake from reaching the sleep frequency or wake frequency.

❖ Related Parameters: A04

- **A85 Wake up frequency**
 - Range: Sleep Frequency (A83) ~ Max Frequency (A04) in 0.01 Hz

Program the frequency setpoint when the VFD wakes up from the Sleep mode for the specified operation.

❖ Related Parameters:

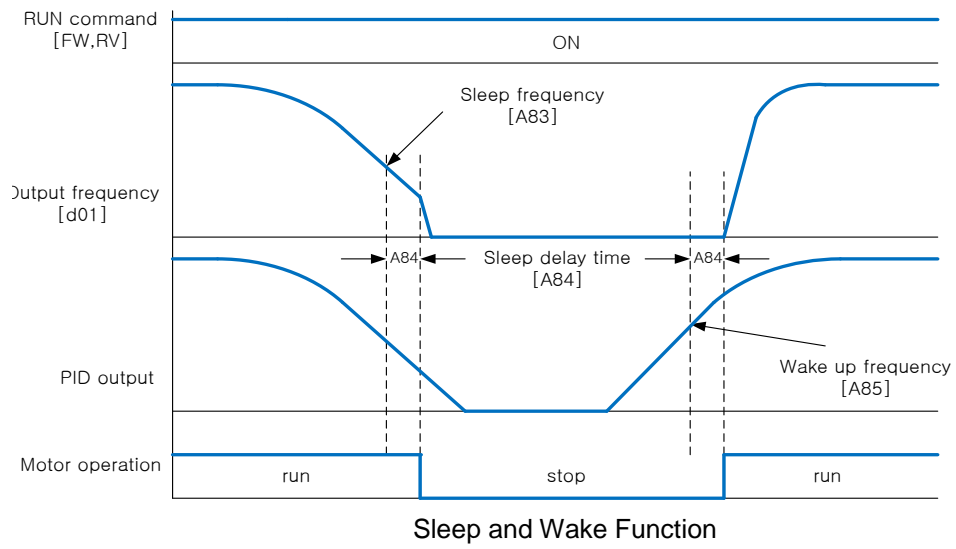

PID Control Diagram

- The overall PID control diagram with respective parameters is shown in Figure 3-1

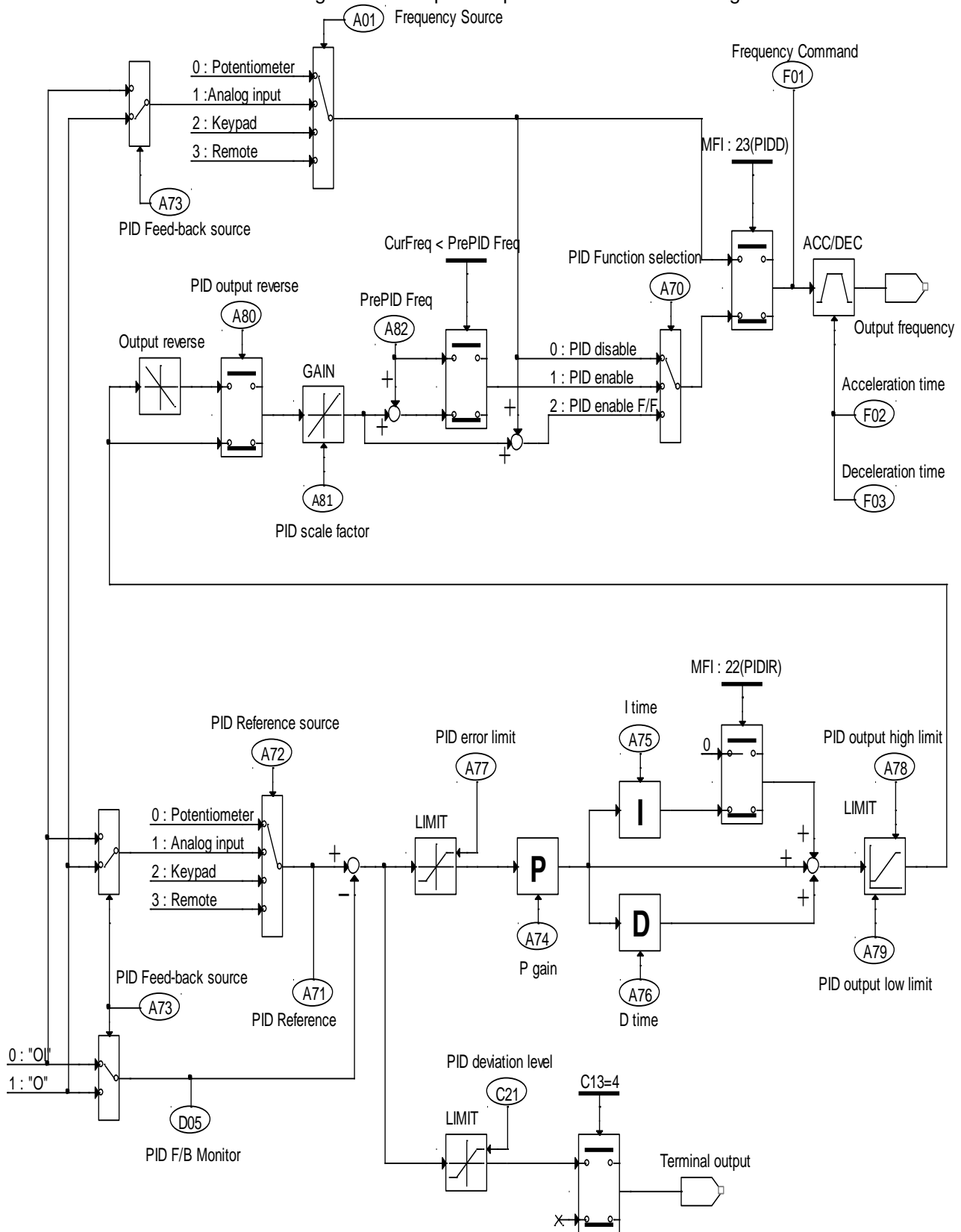

Figure 3-1: PID diagram

- **A86 User V/F setting frequency 1**
 - Range: 0.0 ~ A88 Hz in 0.01 Hz

When selecting VF_USER in A31, the user can set the V/F ratio required by special motor.

 - ❖ Related Parameters: A31, A86~A93

- **A87 User V/F setting voltage 1**
 - Range: 0.0 ~ A89 % in 0.1 %

When selecting VF_USER in A31, the user can set the V/F ratio required by special motor.

 - ❖ Related Parameters: A31, A86~A93

- **A88 User V/F setting frequency 2**
 - Range: A86 ~ A90 Hz in 0.01 Hz

When selecting VF_USER in A31, the user can set the V/F ratio required by special motor.

 - ❖ Related Parameters: A31, A86~A93

- **A89 User V/F setting voltage 2**
 - Range: A87 ~ A91 % in 0.1 %

When selecting VF_USER in A31, the user can set the V/F ratio required by special motor.

 - ❖ Related Parameters: A31, A86~A93

- **A90 User V/F setting frequency 3**
 - Range: A88 ~ A92 Hz in 0.01 Hz

When selecting VF_USER in A31, the user can set the V/F ratio required by special motor.

 - ❖ Related Parameters: A31, A86~A93

- **A91 User V/F setting voltage 3**
 - Range: A89 ~ A93 % in 0.1 %

When selecting VF_USER in A31, the user can set the V/F ratio required by special motor.

 - ❖ Related Parameters: A31, A86~A93

- **A92 User V/F setting frequency 4**
 - Range: A90 ~ A04 Hz in 0.01 Hz

When selecting VF_USER in A31, the user can set the V/F ratio required by special motor.

 - ❖ Related Parameters: A31, A86~A93

- **A93 User V/F setting voltage 4**
 - Range: A91 ~ 100.0 % in 0.1 %

When selecting VF_USER in A31, the user can set the V/F ratio required by special motor.

 - ❖ Related Parameters: A31, A86~A93

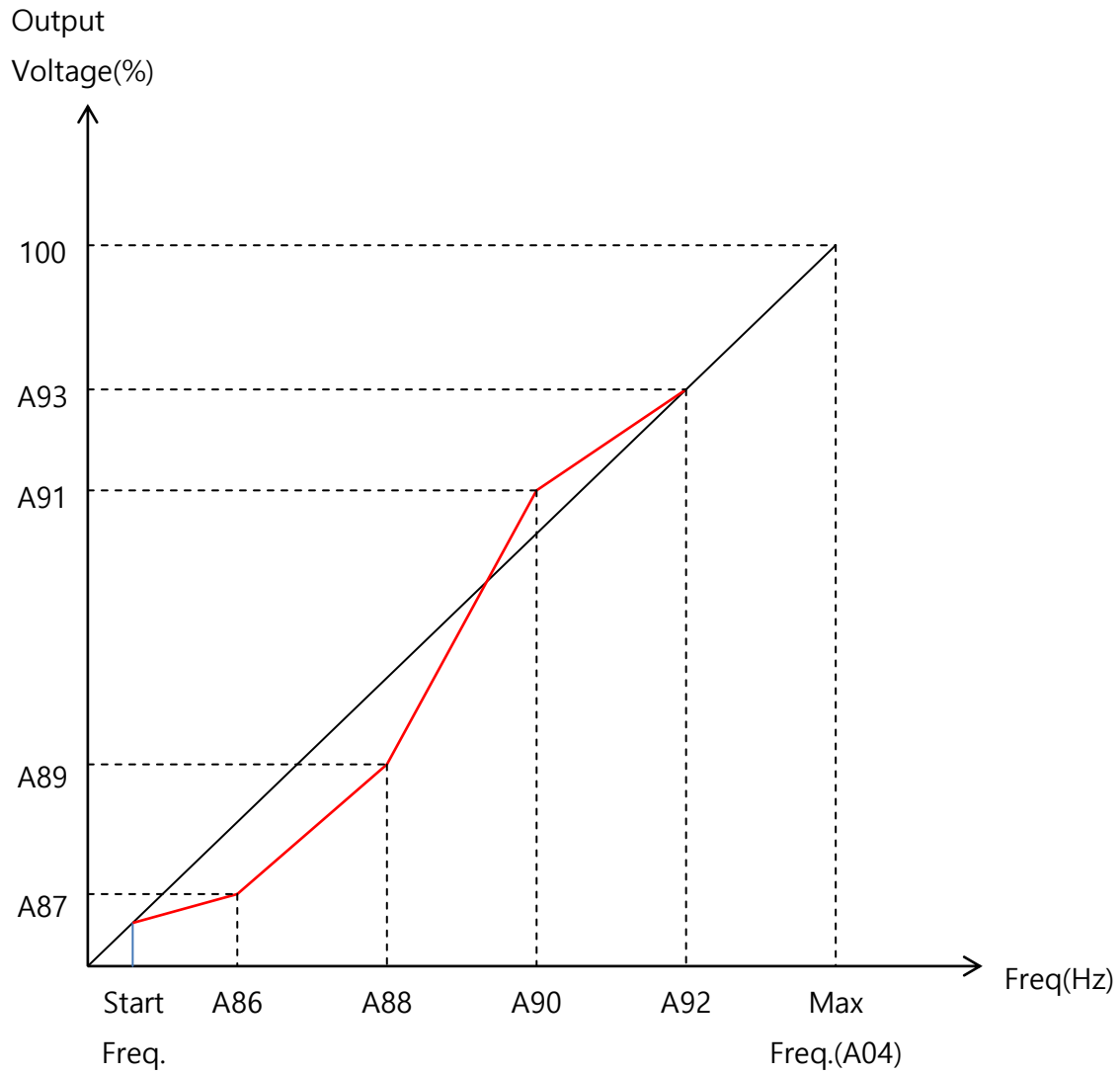

- **A94 FAN fault Detection**
 - 0: ignore FAN trip
 - When FAN failed, inverter keep operation without trip or alarm
 - 1: FAN trip Enable
 - When FAN failed, inverter cut output and display FAN trip (E33)
 - 2: FAN alarm display
 - When FAN failed, inverter keep operation with alarm display (FANt)
- ❖ Related Parameters:

5.5 B Group Parameters

- **b01 Selection of restart mode**
 - 0: No Restart
 - 1: Restart from 0Hz
 - 2: Restart from the frequency at time of fault
 - 3: Restart from the frequency at time of fault; then slow down to stop

Select what action to take when a trip occurs for Over current (OC), Overvoltage (OV), and Under voltage (UV). Restart attempts up to 3 times for OC and OV since there is liability issues to consider. However, in case of UV, it attempts 10 times. For trip count, if the consecutive trip does not occur within 60 seconds, an accumulated trip count is reset to 0. See b24 section.

❖ Related Parameters: b24

- **b02 Allowable instantaneous power failure time setting**
 - Range: 0.3 ~ 10.0 Sec in 1.0 Sec

Program the period for VFD go through under voltage condition without UV trip. This time varies depending upon the loading. Thus, a user must perform the test prior to entering the time value.

❖ Related Parameters:

- **b03 Reclosing standby after Instantaneous power failure recovered**
 - Range: 0.3 ~ 10.0 Sec in 0.1 Sec

Frequency value of VFD output Voltage.

It is the value specified on the Motor nameplate.

❖ Related Parameters:

i) Momentary Power Failure Period < b02

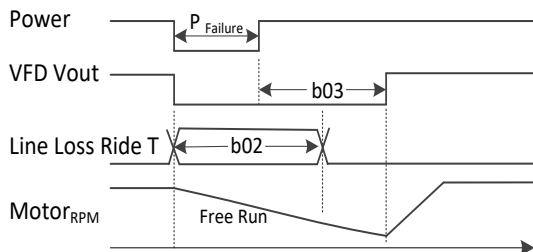

ii) Momentary Power Failure Period > b02

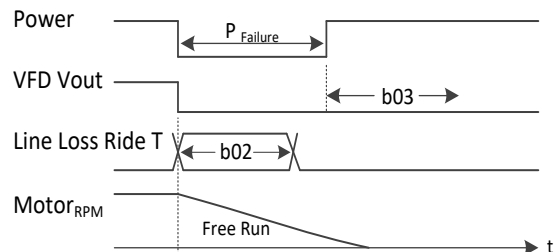

- **b04 Electronic thermal level setting**
 - Range: 20.0 ~120.0 % in 0.1 %

Program a level of the rated motor current (INV Rated Current)

❖ Related Parameters:

- **b05 Electronic thermal characteristic, selection**
 - 0: Self Cooling – Fan is mounted on the motor shaft
 - 1: Forced Cooling – Fan is powered by external power source

Select a cooling method

❖ Related Parameters:

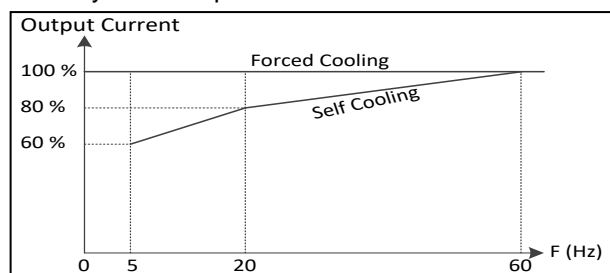

i) b05 = 1: Trip Time vs. Motor Current

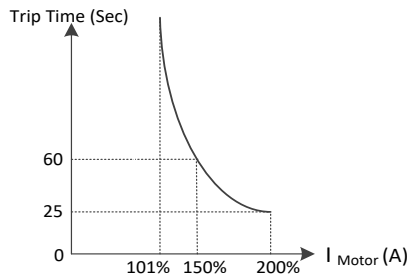

ii) b05 = 0: Trip Time vs. Motor Current

Output Frequency = 20 Hz Output Frequency = 5 Hz

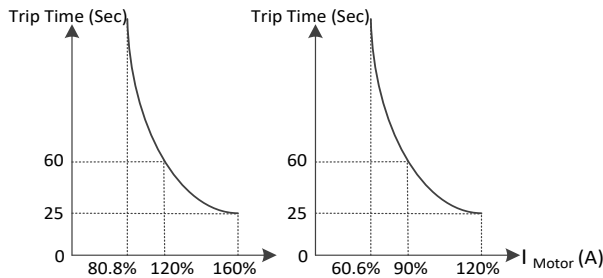

● **b06 Overload overvoltage Restriction mode selection**

- 0: Disable
 - 1: Enable (Stay Current Frequency)
 - 2: Enable(B08)
 - 3: Enable(Max 20% of F02 Value).
- * Overvoltage setting is b67

User can select to overload limit mode at function code b06. This is a function to suppress excessive increase in output current during acceleration or constant speed operation. If the current rised above the b07 and b49 set value, it is lowered the output frequency. However, in constant speed operation, regardless of b06 setting value, only the frequency control according to the setting value of b08. Overload limiting operation is not performed when the function code b06 is set to 0.

❖ Related Parameters: b08, b67

● **b07 Overload restriction level setting (constant speed)**

- Range: Set Between 20%~200% of rated current of inverter
- HD: 20.0%~ 200.0%
- ND: 20.0%~ 165.0%

*Overload limit level during acceleration and deceleration : function code b 49

Program the level for overload restriction % of the VFD rated current

❖ Related Parameters: b49

● **b08 Overload restriction constant setting**

- Range: 0.1~10.0 Sec in 0.1 Sec

Program the deceleration time for the rate when the VFD detects the overload

❖ Related Parameters:

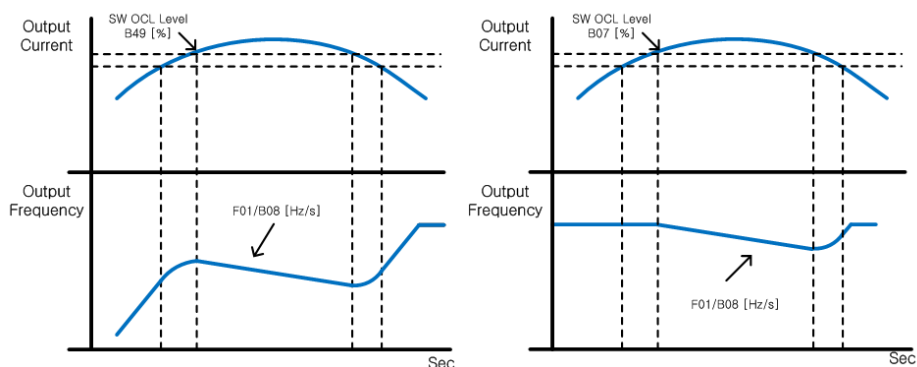

- **b09 Software lock mode selection**
 - 0: All Parameters are locked except b09 when SFT terminal input is ON
 - 1: All Parameters are locked except b09 and F01 by SFT terminal Signal
 - 2: All Parameters are locked except b09
 - 3: All Parameters are locked except b09 and F01
 - 4: All parameters are locked except b09, F01, F02, and F03

Software Lock mode to prevent any un-intentional modification of set parameter values

 - ❖ Related Parameters:
- **b10 Start Frequency Adjustment**
 - Range 0.50 ~ Max. frequency(A04) Hz in 0.01 Hz

Setting the starting frequency from the VFD output

 - ❖ Related Parameters:
- **b11 Carrier frequency setting**
 - Range 0.75 ~ 16.0 Hz in 0.1 kHz (0.4kW~3.7kW)
 - Range 0.75 ~ 10.0 Hz in 0.1 kHz (5.5kW~22kW)

Select Heavy Duty or Normal Duty factory setting per VFD model and loading type

 - ❖ Related Parameters:
- **b12 Initialization mode**
 - 0: Trip history clear
 - 1: Parameters except b13(Country Code) and A53(Motor Input Voltage)

Select an initialization mode

 - ❖ Related Parameters:
- **b13 Country code for initialization**
 - 0: Korea version
 - 1: Europe version
 - 2:US version

Select a country code of which default parameter values to use

 - ❖ Related Parameters:
- **b14 RPM conversion factor setting**
 - Range: 0.01 ~ 99.99 in 0.01

Program RPM Scale factor for d08 Display

 - ❖ Related Parameters: d08
- **b15 STOP key validity during terminal operation**
 - 0: Enabled
 - 1: Disabled

To avoid un-desired stop by pressing the STOP key on the panel by some other operator when the main operation is being performed by terminal or remotely.

 - ❖ Related Parameters:
- **b16 Resume on FRS cancellation mode**
 - 0: Start from 0Hz
 - 1: Restart from frequency corresponding motor speed

Select what frequency VFD to resume its operation when the Free Run Sop (FRS) is cancelled.

 - ❖ Related Parameters: b03

i) When b16=0

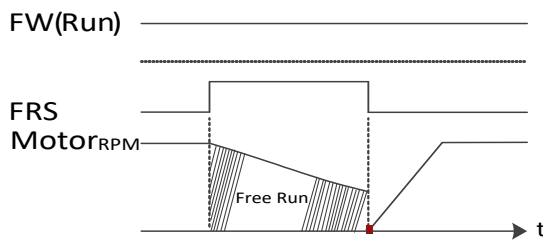

i) When b16=1

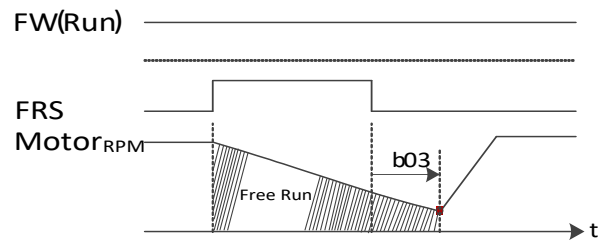

- **b17 Communication number**

- Range: 1~32
- Node ID for Modbus Communication
 - ❖ Related Parameters:

- **b18 Ground fault setting**

- Range: 0.0 ~ 100.0 % in 0.1 %
- 0: Do not detect ground fault

* Below 22kW, disable ground fault setting. (value is always 0)
 Upper 30kW, able to use as above range.

Program to enable the Ground fault detection and its fault level as a percentage of rated current. For iMaster C1 models under 3.7 kW(5 HP), this function is turned off from the Factory

- ❖ Related Parameters:

- **b19 Speed Search Delay Time**

- Range: 0.1 ~ 30.0 s in 0.1 s

Controls delay time during speed search motion on the basis of the motor rated current

- ❖ Related Parameters: b19~b23

- **b20 Voltage increase Time during Speed Search**

- Range: 0.1 ~ 10.0 s in 0.1 s

Can set the voltage increase time in case the current is lower than reference current level. Low value in B20 function code may cause an overcurrent trip.

- ❖ Related Parameters: b19~b23

- **b21 Current limit level of Speed Search**

- Range: 50.0 ~ 180.0 % in 0.1 % (Inverter rated current)

limits excessively increasing current during speed search. When current reached to the setting level, it controls the voltage increasing level to prevent the overcurrent trip
 This may cause a longer time than the setting time at function code b20

- ❖ Related Parameters: b19~b23

- **b23 Frequency match operation selection**

- 0: 0Hz Starting operation
- 1: Frequency matching & start operation

In case of inverter starting operation, the start frequency of the inverter can be selected as follows

- ❖ Related Parameters: b19~b20,b23

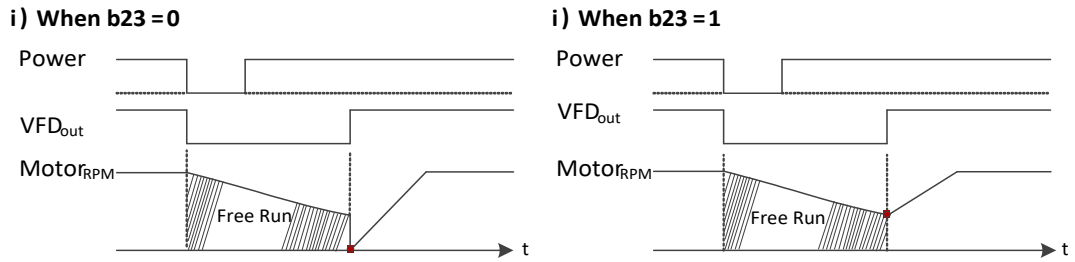

- **b24 Failure status output selection by relay in case of failure**

- 0: Inactive at low voltage failure
- 1: Active at voltage failure(Inactive at restart mode)
- 2: Active of all failure occurred
- 3: Active at voltage failure(For low voltage failure, automatic restart)

Combined with Restart, b01 select, various method can be selected as summarized for “Overvoltage and Over current” trip and “Under voltage” trip respectively.

❖ Related Parameters:

Table 3-1: Restart and Relay 1 Operation When Over Voltage or Over Current Trip

*case (b24=0) & (b24=3) are modified from the original design concept shown in Under Voltage case due to the safety concerns Thus, both cases look exactly the same as (b24=1). A first user may be confused by many different cases show the same outcome.

b24: Relay 1 Select b01: Restart Select	b24 = 0 *	b24 = 1	b24 = 2	b24 = 3 *
	No Relay 1 Activated originally, but, for OV & OC, Activated for Safety	Yes, Relay 1 is activated when long steady Trip signal	Yes, Relay 1 for every Trip signal	Relay 1 activated when long Trip signal Auto Reset to Restart is banned for safety
b01 = 0 No Restart				
b01 = 1 Yes Restart @ 0 Hz	<p>@ 1st Trip, No Relay 1 but Restart from 0 Hz But if Trips Again @ 2nd Trip, No Relay 1 & Restart from 0 Hz @ 3rd Trip, No Relay 1 & Restart from 0 Hz @ 4th Trip, Yes Relay 1 & Wait for User Act</p>	<p>@ 1st Trip, No Relay 1 but Restart from 0 Hz But if Trips Again @ 2nd Trip, No Relay 1 & Restart from 0 Hz @ 3rd Trip, No Relay 1 & Restart from 0 Hz @ 4th Trip, Relay 1 On & Wait for User Act</p>	<p>@ 1st Trip, Relay 1 On & Restart from 0 Hz But if Trips Again @ 2nd Trip, Relay 1 On & Restart from 0 Hz @ 3rd Trip, Relay 1 On & Restart from 0 Hz @ 4th Trip, Relay 1 On & Wait for User Act</p>	<p>@ 1st Trip, Relay 1 On & Restart from 0 Hz But if Trips Again @ 2nd Trip, Relay 1 On & Restart from 0 Hz @ 3rd Trip, Relay 1 On & Restart from 0 Hz @ 4th Trip, Relay 1 On & Wait for User Act</p>
b01 = 2 Yes Restart @ M' Hz	<p>@ 1st Trip, No Relay 1 but Restart @ M' Hz But if Trips Again @ 2nd Trip, No Relay 1 & Restart @ M' Hz @ 3rd Trip, No Relay 1 & Restart @ M' Hz @ 4th Trip, Relay 1 On & Wait for User Act</p>	<p>@ 1st Trip, No Relay 1 but Restart @ M' Hz But if Trips Again @ 2nd Trip, No Relay 1 & Restart @ M' Hz @ 3rd Trip, No Relay 1 & Restart @ M' Hz @ 4th Trip, Relay 1 On & Wait for User Act</p>	<p>@ 1st Trip, Relay 1 On & Restart @ M' Hz But if Trips Again @ 2nd Trip, Relay 1 On & Restart @ M' Hz @ 3rd Trip, Relay 1 On & Restart @ M' Hz @ 4th Trip, Relay 1 On & Wait for User Act</p>	<p>@ 1st Trip, Relay 1 On & Restart @ M' Hz But if Trips Again @ 2nd Trip, Relay 1 On & Restart @ M' Hz @ 3rd Trip, Relay 1 On & Restart @ M' Hz @ 4th Trip, Relay 1 On & Wait for User Act</p>
b01 = 3 Yes Restart @ M' Hz & Stop	<p>@ 1st Trip, VFD Restart from M' Hz But Slow down to stop @ Stop, Trip goes back on and Relay 1 Activated</p>	<p>@ 1st Trip, VFD Restart from M' Hz But Slow down to stop @ Stop, Trip goes back on and Relay 1 Activated</p>	<p>@ 1st Trip, VFD Restart from M' Hz But Slow down to stop @ Stop, Trip goes back on and Relay 1 Activated</p>	<p>@ 1st Trip, VFD Restart from M' Hz But Slow down to stop @ Stop, Trip goes back on and Relay 1 Activated</p>

Table 3-2: Restart and Relay 1 Operation When Under Voltage Trip

b24: Relay 1 Select b01: Restart Select	b24 = 0 No Relay 1 Activated	b24 = 1 Yes, Relay 1 is activated when long steady Trip signal	b24 = 2 Yes, Relay 1 for every Trip signal	b24 = 3 Relay 1 activated when long Trip signal then auto Reset to Restart
b01 = 0 No Restart				
b01 = 1 Yes Restart @ 0 Hz	<p> @ 1st Trip, No Relay 1 but Restart from 0 Hz But if Trips Again @ 2nd Trip, No Relay 1 & Restart from 0 Hz @ 11th Trip, No Relay 1 & Wait for User Act </p>	<p> @ 1st Trip, No Relay 1 but Restart from 0 Hz @ 2nd Trip, No Relay 1 & Restart from 0 Hz @ 11th Trip, No Relay 1 & Wait for User Act </p>	<p> @ 1st Trip, Relay 1 On & Restart from 0 Hz @ 2nd Trip, Relay 1 On & Restart from 0 Hz @ 11th Trip, Relay 1 On & Wait for User Act </p>	<p> @ 1st Trip, No Relay 1 but Restart from 0 Hz @ 2nd Trip, No Relay 1 & Restart from 0 Hz @ 11th Trip, Relay 1 On then Auto Reset and Restart from 0 Hz </p>
b01 = 2 Yes Restart @ M' Hz	<p> @ 1st Trip, No Relay 1 but Restart @ M' Hz But if Trips Again @ 2nd Trip, No Relay 1 & Restart @ M' Hz @ 11th Trip, No Relay 1 & Wait for User Act </p>	<p> @ 1st Trip, No Relay 1 but Restart @ M' Hz But if Trips Again @ 2nd Trip, No Relay 1 & Restart @ M' Hz @ 11th Trip, No Relay 1 & Wait for User Act </p>	<p> @ 1st Trip, Relay 1 On & Restart @ M' Hz @ 2nd Trip, Relay 1 On & Restart @ M' Hz @ 11th Trip, Relay 1 On & Wait for User Act </p>	<p> @ 1st Trip, No Relay 1 but Restart @ M' Hz But if Trips Again @ 2nd Trip, No Relay 1 & Restart @ M' Hz @ 11th Trip, Relay 1 On then Auto Reset and Restart from 0 Hz </p>
b01 = 3 Yes Restart @ M' Hz & Stop	<p> @ 1st Trip, VFD Restart from M' Hz But Slow down to stop @ Stop, Trip goes back on and Relay 1 NOT Activated </p>	<p> @ 1st Trip, VFD Restart from M' Hz But Slow down to stop @ Stop, Trip goes back on and Relay 1 Activated </p>	<p> @ 1st Trip, VFD Restart from M' Hz But Slow down to stop @ Stop, Trip goes back on and Relay 1 Activated </p>	<p> @ 1st Trip, VFD Restart from M' Hz But Slow down to stop @ Stop, Trip goes back on and Relay 1 Activated </p>

- **b25 Stop method selection**

- 0: Decelerating stop
- 1: Coast to Stop (Free Run to Stop)

Select a stop method when Stop command is given.

❖ Related Parameters:

- **b26 Inverter type change to P-type (Normal Duty)**

- 0: Heavy Duty (HD): Constant Torque Load Type (bellow 3.7kw, value is always 0)
- 1: Normal Duty (ND): Variable Torque Load Type

Select a torque type for appropriate “Rated Power” and “Overload Tolerance” values. For instance, for Fans, or centrifugal pump applications, select ND and Hoists, conveyors, pump process, select HD. Factory setting of Carrier Frequency value for HD and ND in the table.

❖ Related Parameters: b11

- **b27 Input phase loss**

- 0: Disabled
- Range: 0 ~ 30 Sec in 1 Sec

Enables & sets the time period to determine if an Input Phase Loss occurs. The VFD monitors the ripple on the DC bus voltage and if it occurs for the programmed magnitude and time period an Input Phase Loss fault will occur. The ripple on the DC bus will cause heating to the DC Bus capacitors which will shorten their life.

❖ Related Parameters:

- **b28 Communication time out setting**

- 0: Disabled
- Range: 0 ~ 60 Sec in 1 Sec

Select a time out detection period when communication discontinues. If no communication event occurs during this time period, a communication fault will occur.

❖ Related Parameters:

- **b29 Communication time out operation mode**

- 0: Always active
- 1: Active in case of inverter is running

Select a time out detection mode.

❖ Related Parameters:

- **b30 Display code setting**

- Range: 1 ~ 13 (for d01 ~ d13)

Select an initial display parameter at power on

❖ Related Parameters:

- **b31 2nd communication channel 485 communication speed setting**

- 1: 2,400 bps
- 2: 4,800 bps
- 3: 9,600 bps
- 4: 19,200 bps
- 5: 38,400 bps

Select a baud rate for the RXP-RXN terminal communication RS485 channel

❖ Related Parameters:

- **b32 BRD selection**
 - 0: Disabled
 - 1: Enable only during inverter running
 - 2: Enable

This BRD function is only applicable to iMaster C1 models under 22kW(30 HP) Regenerative energy from the motor is dissipated by the heat through this braking resistor module.

❖ Related Parameters:

- **b33 BRD using ratio**
 - Range: 0.0 ~ 10.0 % in 0.1 % (0.4kW~3.7kW)
 - Range: 0.0 ~ 50.0 % in 0.1 % (5.5kW~22kW)

Select a percentage value of total BRD on time before the overheating fault occurs

❖ Related Parameters:

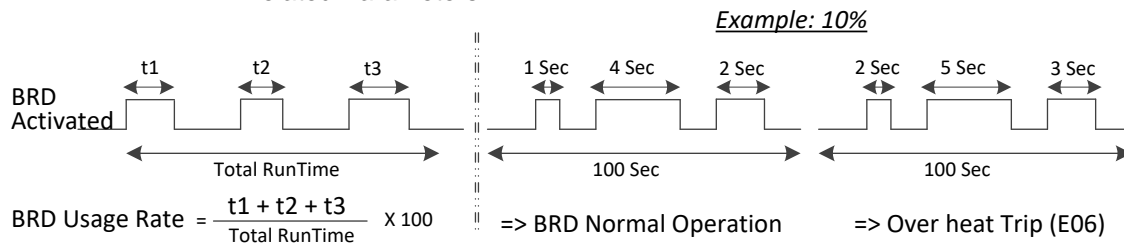

◆ b34 ~ 41 Overvoltage Suppression(OVS) Function

The Overvoltage Suppression (OVS) feature will over speed the motor up to the Maximum OVS Output Frequency (b34) to prevent motor regeneration and creating an Overvoltage Fault. If the OVS runs at maximum frequency for longer than the Limit Time (b41), the unit will fault on E02.

OVS Functional Description

- By calculating torque in real time, reduce regeneration energy by increasing speed.
- For speed control, PI controller is applied.
- If torque is bigger than 0, "PI Out" become 0 by "PI Limiter"; no increase in frequency value
- If torque is lower than 0, "PI Out" would be increased to "Max Add Req"; frequency value increased
- If output of PI controller is reached to b34(Max Add Freq) The counter is started.
- When the value of counter is reached to b41 (wRegen Time), the trip(E02) will be occur.

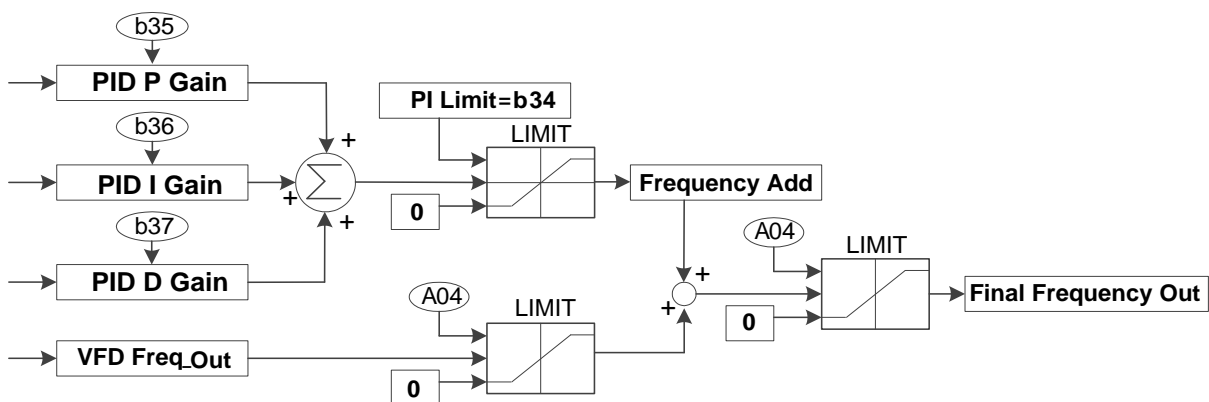

Parameters

Code	Name	Range	Default	Unit	Run-time edit
b34	Maximum OVS Output Frequency	0.00 ~ 300.0	80.00	Hz	O
b35	PID P Gain (Voltage suppression P gain)	0.0 ~ 100.0	10.00	-	O
b36	PID I Gain Time (Voltage suppression I gain)	0.0 ~ 100.0	1.00	Sec	O
b37	PID D Gain Time (Voltage suppression D gain)	0.0 ~ 100.0	1.00	Sec	O
b38	q-Current Reference(q axis reference current)	-100.0~100.0	0.0	-	O
b39	Filter Bandwidth(q axis LPF coefficient)	0.0~1000	1	mS	O
b40	Overvoltage Suppression(wDec Mode)	0: Disabled 1:Enabled	0	-	O
b41	Limit Time(wRegen Time)	0.0~1000	0.5	Sec	O

Setting Parameters

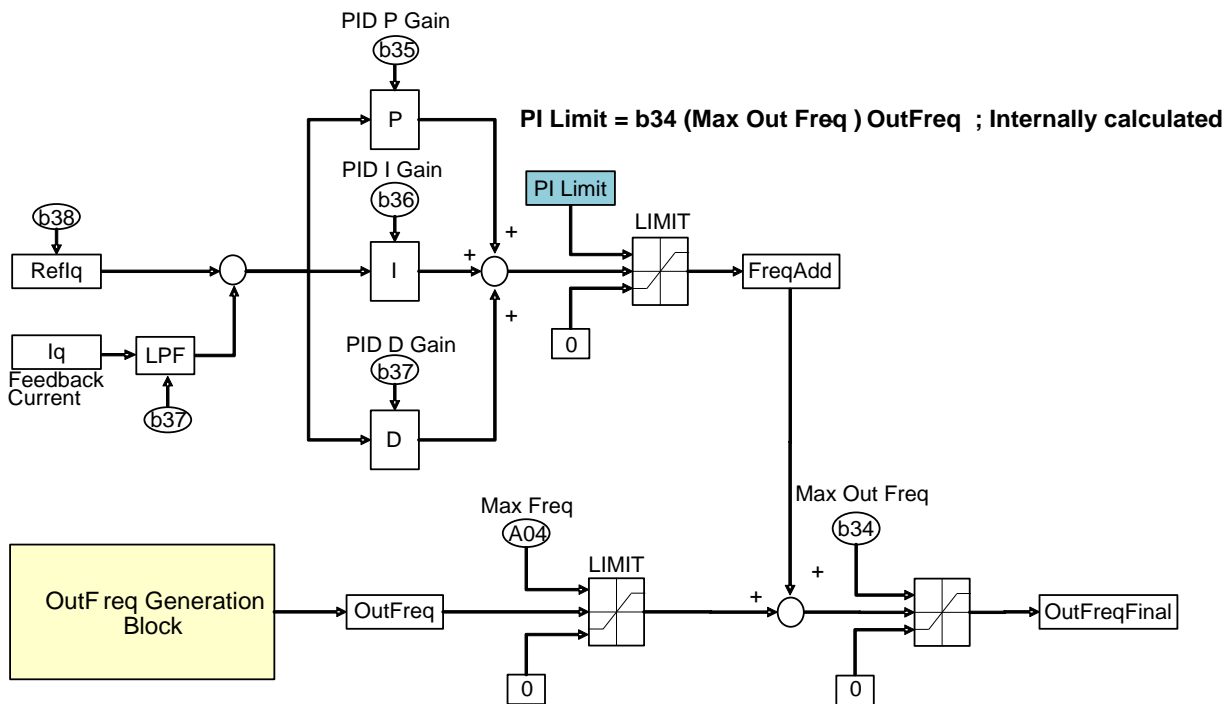

Meaning of b34 is changed from Max Add Freq to Max Out Freq

- **b34** **Maximum OVS output frequency**
 - Range: 0.0 ~ 300.0 Hz in 0.1 Hz

Real time editable a maximum frequency limit for OVS function

❖ Related Parameters:

- **b35 OVS P gain**

- Range: 0 ~ 100.00 % in 0.01%
 - Real time editable P gain for OVS PID loop
 - $PIOut = err * Kp$
 - $Hz = err(\%) * Kp * scalefactor(50 * 1e-6)$

Example

- err 10%, $Kp = 1000$
 - ⇒ $PIOut = 0.5Hz$
- ✓ Recommended Value in test bench
 - ⇒ 1000 or less than 5000

❖ Related Parameters

- **b36 OVS I gain**

- Range: 0 ~ 100.00 % in 0.01%

Real time editable I gain for OVS PID loop

- $PIOut = \int(err * Ki)$
- $Hz += err(\%) * Ki * scalefactor(50 * 1e-6), dT = 1msec$

Example (Integration Time to 10Hz on Error)

- err 10%, $Ki = 1000$
 - ⇒ Time to 10Hz on 10% Error = 20msec
- err 10%, $Ki = 100$
 - ⇒ Time to 10Hz on 10% Error = 200msec
- err 10%, $Ki = 10$
 - ⇒ Time to 10Hz on 10% Error = 2000msec
- ✓ Recommended Value in test bench
 - ⇒ 100 or less than 500

❖ Related Parameters:

- **b37 OVS D gain**

- Range: 0 ~ 100.00 % in 0.01%

Real time editable D gain for OVS PID loop. Its value depends on b39; filter bandwidth. Thus, if b39 is not changed, no need to change OVS PID D Gain value. Most application, this value should not be set over 3000

- ✓ Recommended Value as a function of b39
 - ⇒ If $b39 < 10$ → b37: 0 ~ 500
 - ⇒ If $b39 < 30$ → b37: 500 ~ 1000
 - ⇒ If $b39 < 50$ → b37: 1000 ~ 1500

❖ Related Parameters:

- **b38 Q axis reference (q axis reference current)**

- Range: -100.0 ~ 100.0 in 0.1

Real time editable q axis reference current compensates Torque Estimate Error.

- If Torque estimate offset is bigger than 0
 - ⇒ No increase in output frequency even if regeneration is occurred.
 - ⇒ This situation could be end with OV Trip.
 - ⇒ If so, set b38 to a positive value
- If Torque estimation offset smaller than 0
 - ⇒ No increase in output frequency even if regeneration is not occurred.
 - ⇒ Output Frequency could be increased to Max. Freq (Reference Frequency + b34) and end up with E02 (OVS Fail)
 - ⇒ If so, set b38 to a negative value

❖ Related Parameters

- **b39 Filter bandwidth (q axis LPF coefficient)**

- Range: 0 ~ 1000 milliseconds in 1 mSec

Real time editable Iq feedback Low Pass Filter time constant

- If output Frequency is not stable,
 - ⇒ Increase b39 value
- Recommended Value as a function of (b39); (b37) value should be set accordingly
 - ⇒ Not set over 50

❖ Related Parameters:

- **b40 Overvoltage suppression (wDec Mode)**

- 0: Disabled
- 1: Enable for current
- 2: Enable for voltage

Select to enable the Voltage Suppression Control function.

❖ Related Parameters:

- **b41 Limit Time (wRegen Time)**
 - Range: 0.0 ~ 100.0 Sec in 0.1 Sec

Real time editable OVS control fail check time. If PID output is saturated to Maximum OVS output Frequency (b34) during this time period, VFD will stop and E02 will be occurred.

❖ Related Parameters:

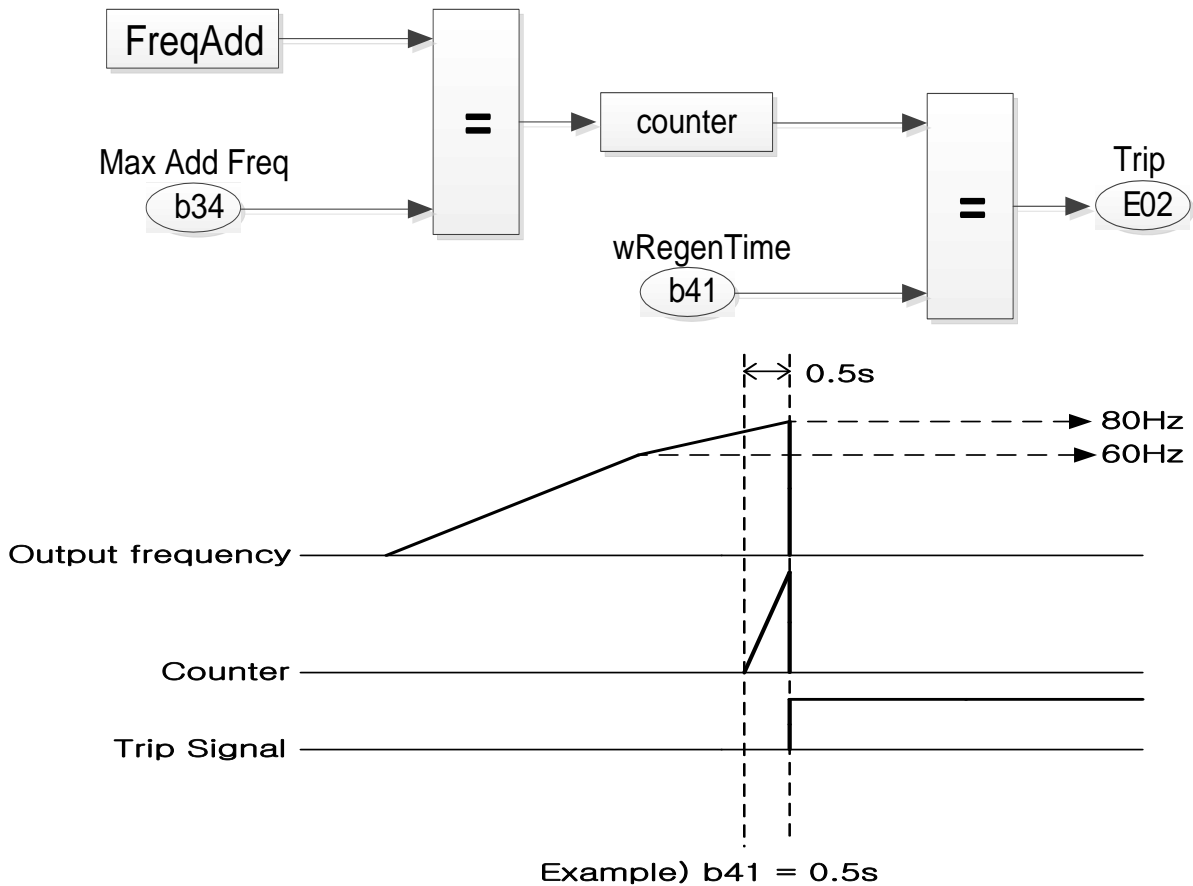

Case1) If frequency is increased at no regeneration condition,

- Cause: when a current feedback value is corrupted by noise.
- Measures:
 - ✓ Change a b39(Filter of current F/B) and b37(D gain)
Please set the b39 between 5 and 30 (ex 5, 10, 20, 30ms)
Increasing b39 results the delay in calculating torque so b37 should be set .
Please set the b37 between 500 to 1000
 - ✓ Experimental values on MG-Set test are
b39: 30, b37: 1000

Case2) If overvoltage trip is occurred at normal operation,

- Cause: Torque is over estimated due to motor parameter error or current sensing error.
- Measures :
 - ✓ Change a b38(Reference Current)
Please set the b39 between 30 to 100
If this value is set too high, Frequency output can be saturated to maximum frequency.

Calculated torque output

User can monitor calculated torque by 2 methods

■ Parameters

Code	Name	Description	default	Run-time Edit
C18	wAODef (FM Output selection)	0 ~ 6	0	X
C25	wAODef2(AM Output selection)	0 ~ 6	1	X

■ Analog output (DC voltage)

➤ C18 (FM Output selection)

Set "C18=4" display calculated torque value (-150%~+150%) by analog output.

FM output	Torque
0V	-150%
5V	0%
10V	+150%

(※ C18 = 0~3 are the same as existed function)

■ Analog output (current)

➤ C25 (AM Output selection)

Set "C25=4" display calculated torque value (-150%~+150%) by analog output.

AM output	Torque
4mA	-150%
12mA	0%
20mA	+150%

(※ C25 = 0~3 are the same as existed function)

➤ Special parameter: Calculated torque read frame by Modbus

- CMD : 03 (Read)

- Parameter : 10 (Calculated Torque)

	Communication Number	CMD	Parameter	Data Quantity	CRC
TX	01	03	000A	0001	2byte

	Communication Number	CMD	Byte Quantity	Data	CRC
RX	01	03	02	Torque value	2byte

※ This document are written by result of test bench.

Field engineer should be tuned for each field situation by consider above case study.

b42 ~ b46 (Extended A33 ~ A37) – Also Explained in A -Group

- **b42 VFD start delay time after DC injection braking**
 - Range: 0.0 ~ 60.0 Sec in 0.1 Sec
 - Program the VFD start delay time after braking time at start is done
 - ❖ Related Parameters: A33, b43~b46

- **b43 DC injection braking time at start**
 - Range: 0.0 ~ 6000.0 Sec in 0.1 Sec
 - Program the DC Injection Braking duration before VFD start
 - ❖ Related Parameters: A33, b42~b46

- **b44 Current controller P gain in DC braking**
 - Range: 1 ~ 100.00 % in 0.01%
 - Program the current controller P gain in DC braking
 - This value is applied both brake modes (start and stop)
 - If motor speed has a large overshoot at DC braking, decrease this value
 - If value is too big, motor can be vibrated or can't be stopped
 - ❖ Related Parameters: A33, b42~b46

- **b45 Current controller I gain time in DC braking**
 - Range: 0 ~ 100.00 Sec in 0.01 Sec
 - Program the current controller I gain in DC braking
 - This value is applied both brake modes (start and stop)
 - If motor is vibrated or not stop at DC braking, decreased this value
 - If value is too big, DC braking force can be weak
 - ❖ Related Parameters: A33, b42~b46

- **b46 DC injection braking force**
 - Range: 0.0 ~ 100.0 % in 0.1 %
 - Program the level of DC injection braking force of rated electric power of iMaster C1
 - ❖ Related Parameters:

- **b49 Overload restriction level at acceleration & deceleration**
 - Range: 20.0 ~ 200.0 (HD)
 - Range: 20.0 ~ 165.0 (ND)
 - Separately programmable overload restriction is that applies only during the acceleration and deceleration periods. This function works the same as b07, but can be configured to a different value to account for the difference in current draw during normal operation and flying start.
 - ❖ Related Parameters:b06, b07, b23

◆ b50 ~ 55 Load Balance Function

Load Balance is a feature that automatically shares the load level between two independent motors driving the same load. The Output Frequency of each motor is independently changed by the amount of torque it is applying. The amount of the increase/decrease is dependent on the amount of torque being applied.

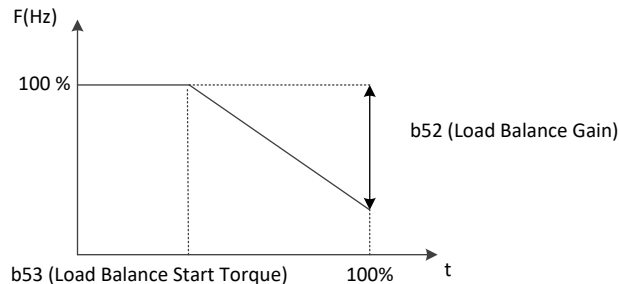

$$\text{Control Frequency} \times \frac{(\text{Output Torque} - \text{Load Balance Start Torque})}{100\% - \text{Load Balance Start Torque}} \times \text{Load Balance Gain} \times \text{Load Balance Target Frequency}$$

- **b50 Droop control start freq.**
 - Range: 0.00 ~ Max. frequency (A04) Hz in 0.01 Hz
 - Sets the frequency where the Load Balance Start Frequency feature is enabled. When running below this frequency the feature is disabled
- **b51 Droop control standard freq.**
 - Range: 10.00 ~ Max. frequency (A04) Hz in 0.01 Hz
 - Sets the frequency where the Load Balance Start Frequency feature is enabled. When running below this frequency the feature is disabled.
- **b52 Droop control gain**
 - Range: 0.00 ~ 50.00 in 0.01
 - Sets the rate of change when this feature is functioning. It is based on a percentage of the output torque being applied.
- **b53 Droop star torque**
 - Range: 0.0 ~ 100.0 % in 0.1 %
 - Sets the amount of output torque applied at start when the Load Balance function is enabled.
- **b54 Droop acceleration time**
 - Range: 0.0 ~ 100.0 Sec in 0.1 Sec
 - Sets the ramp rate applied to the output frequency when the Load Balance function is enabled.
- **b55 Droop control mode**
 - 0: Disabled
 - 1: Enabled
 - **Set 0: Disabled**
Load balance is disabled
 - **Set 1: Enabled**
Load balance works without any feedback

Example

- 1) Increased the load ratio up to 100%
Output frequency decreased by the amount of load

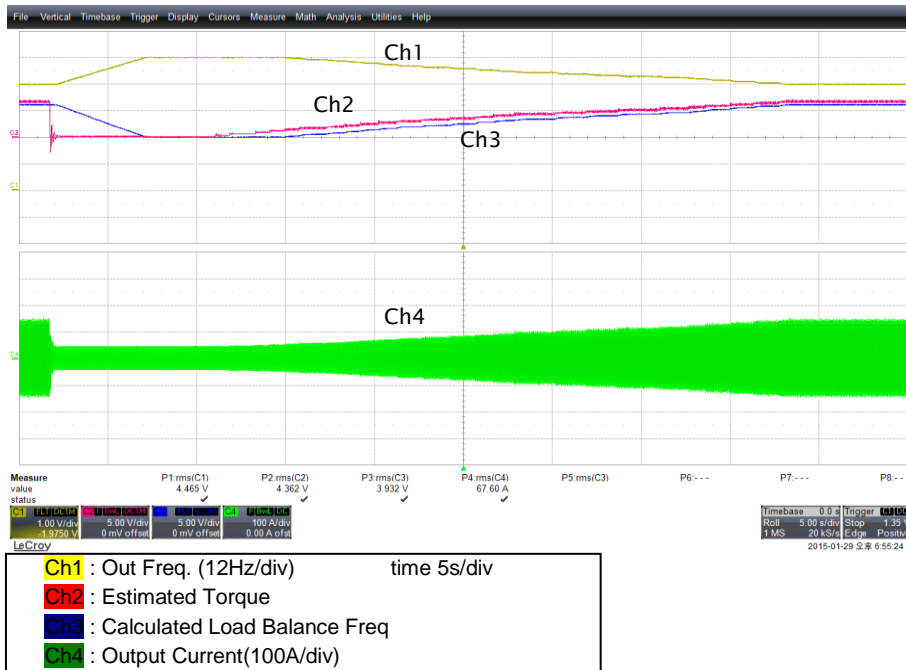

- 2) Put 100% step load and removed 100% load in a moment
Put the step load (100%) for 8 seconds and then remove the step load.
The Load Balance control decreased the output frequency for b54 value (5sec) at step load.
The Load Balance control increased the output frequency for b54 value (5sec) at no step load.

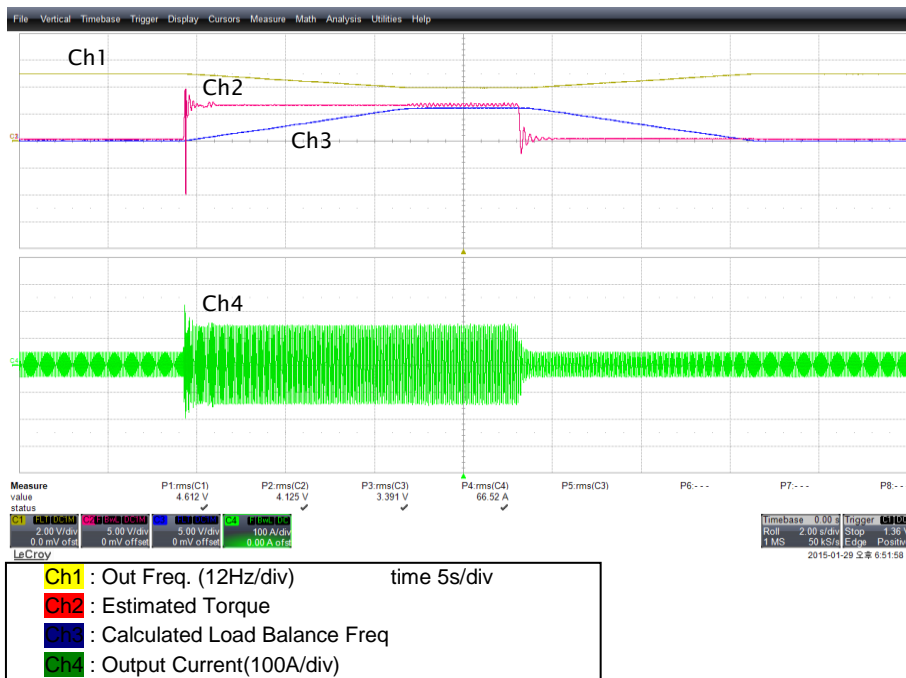

◆ **b56 ~ 60 Motor load detection**

The drive provides two independent torque detection functions that trigger an alarm or fault signal when the load is too heavy or suddenly drops

● **b56 Motor load detection selection**

- 0: Disabled
- 1: Overload Detection
- 2: Underload Detection
- 3: Overload/Underload Detection
- 4: Overload Detection with Fault (E23)
- 5: Underload Detection with Fault (E24)
- 6: Overload/Underload Detection with Fault (E23, E24)

For settings, 1~6 allows a relay contact to alert an external device, related parameters C13, C14, C15. In addition, setting 4~6 triggers trip signals display on the keypad

● **b57 Motor overload detection level**

- Range: 20.0 ~ 200.0 % in 0.1 %

Sets the System Overload level. This feature is triggered when the motor current exceeds this level. 100% level is based off of the value in H05.

System Overload Detection

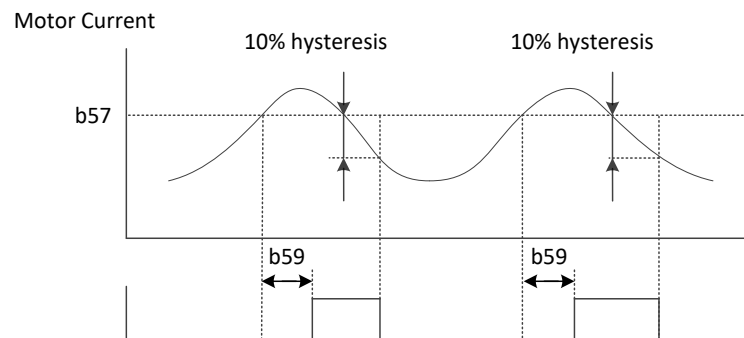

● **b58 Motor underload detection level**

- Range: 20.0 ~ 200.0 % in 0.1 %

Sets the System Underload level. This feature is triggered when the motor current exceeds this level. 100% level is based off of the value in H05.

System Underload Detection

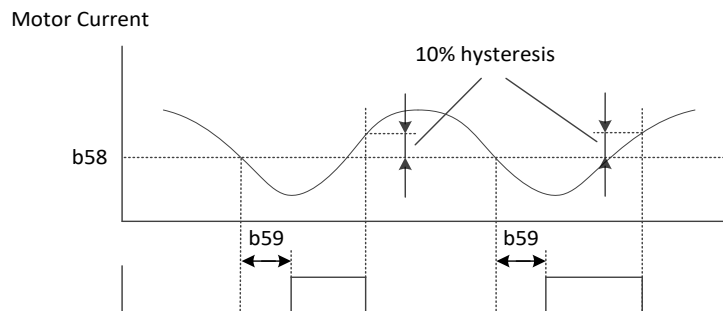

- **b59 **Overload/Underload detection time****
 - Range: 0.0 ~ 60.0 Sec in 0.1 Sec

Sets the System Overload/Underload Detection time.

- **b60 **Overload/Underload detection safe zone****
 - Range: 0.00 ~ Max frequency (A04) in 0.01 Hz

Sets the level at which this feature is disabled.
System Overload/Underload detection doesn't work below b60 value

◆ **b61 ~ 64 Dwell Function**

The Dwell Function temporarily holds the output frequency at a predetermined value for a predetermined time before accelerating or decelerating to the current frequency reference. The Dwell function helps preventing speed loss when starting and stopping a heavy load

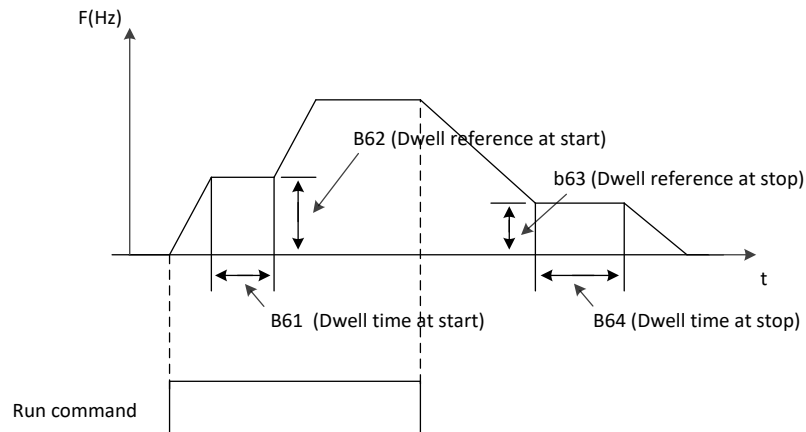

- **b61 **Dwell frequency at start****
 - Range: 0.00 ~ Max frequency (A04) in 0.01 Hz

Program Dwell frequency at start

- **b62 **Dwell time at start****
 - Range: 0.0 ~ 10.0 Sec in 0.1 Sec

Program Dwell time at start

- **b63 **Dwell frequency at stop****
 - Range: 0.00 ~ Max frequency (A04) in 0.01 Hz

Program Dwell frequency at stop

- **b64 **Dwell time at stop****
 - Range: 0.0 ~ 10.0 Sec in 0.1 Sec

Program Dwell time at stop

◆ b65 ~ 66 KEB Function

When power loss is detected, the Kinetic Energy Backup Ride-Thru function (KEB Ride-Thru) decelerates the motor and uses regenerative energy to keep the main circuit operating. Despite power loss, the drive output is not interrupted.

● b65 KEB control selection

- 0: Disabled
- 1: Enable (controlled by setting value of function code b66)
- 2: Enable (controlled by DC link voltage)

● b66 KEB control gain

- Range: 0.1 ~ 100.0 % in 0.1 %

set the degree of rapid deceleration of the motor during KEB operation.

● b67 Overvoltage limit setting

- 0: Disabled
- 1: Enable

● b68 Hold time at running

- Range: 0.0 ~ 60.0 Sec in 0.1 Sec

● b69 Stop frequency setting

- Range: 0.00 ~ Max frequency (A04) in 0.01 Hz

When inverter is stop operation, stop frequency can be set by using B69 code.

● b70 Hold time at stop

- Range: 0.0 ~ 60.0 Sec in 0.1 Sec

It can be set to maintain the set stop frequency (B69) in the inverter stop operation until the set time.

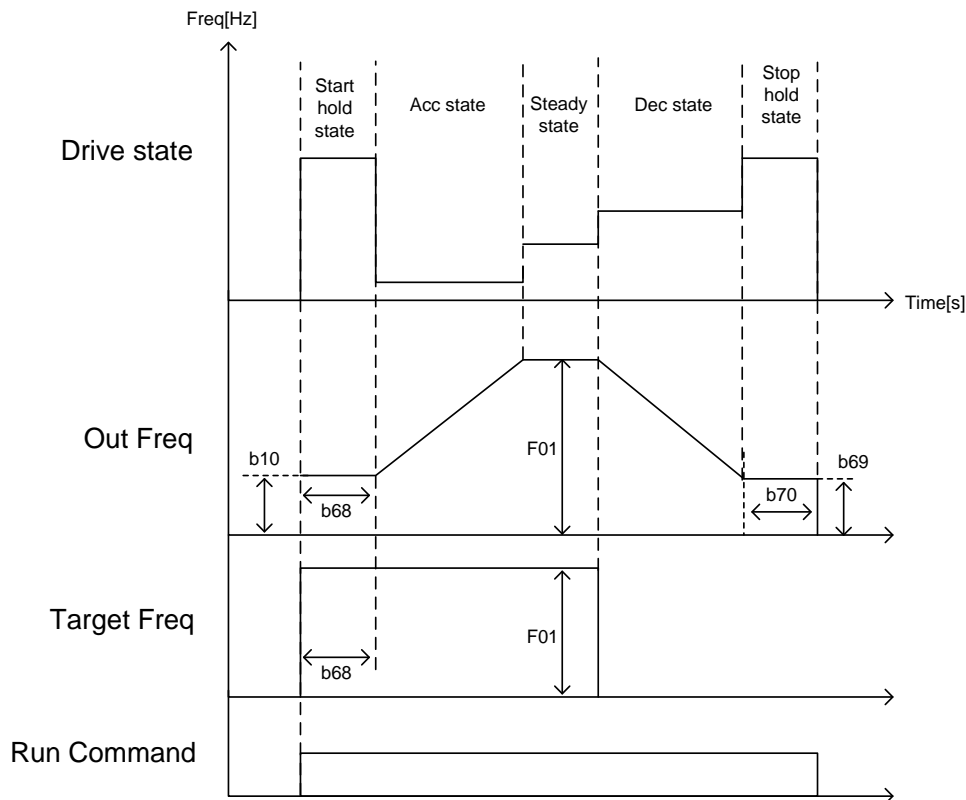

- **b71 User parameter setting**

- 1: Output frequency monitor
- 2: Output current monitor
- 3: Output voltage monitor
- 4: Rotation direction monitor
- 5: PID feedback monitor
- 6: Intelligent terminal input monitor
- 7: Intelligent terminal output monitor
- 8: RPM monitor
- 9: Power consumption monitor
- 10: Display of cumulative time (day)
- 11: Display of cumulative time (minute)
- 12: DC link voltage

Change the F06 (User Display) according to b71 selection.

❖ Related Parameters:b71~b73, F06

- **b72 User mathematical sign**

- 0 - '+' calculation
- 1 - '-' calculation
- 2 - 'X' calculation
- 3 - '/' calculation

F06 (User Display) select the Scale Factor (b73) and the operator(b72) to operate on.

❖ Related Parameters:b71~b73, F06

- **b73 Define user setting**

- Range: 1.00 ~ 600.0 in 0.1

F06 (User Display) select the Scale Factor (b73) and the operator(b72) to operate on.

❖ Related Parameters:b71~b73, F06

5.6 C Group Parameters

INPUT

- **C01~C06 Intelligent Input Terminals 1~6**

These input terminals can be programmed one of following functions.

 - 0: FW Forward Run Command
 - 1: RV Reverse Run Command
 - 2: CF1 Multiple Speed Command 1
 - 3: CF2 Multiple Speed Command 2
 - 4: CF3 Multiple Speed Command 3
 - 5: CF4 Multiple Speed Command 4
 - 6: JG Jogging Operation Command
 - 8: 2CH Acceleration 2/Deceleration 2 Command
 - 9: FRS Free Run Stop Command
 - 10: EXT External Trip 1
 - 11: USP Unattended Start Protection
 - 12: SFT Software Lock Function
 - 13: AT Analog Input Current/Voltage Selection
 - 14: RS Reset
 - 15: STA Start
 - 16: STP Keep
 - 17: F/R Forward / Reverse
 - 18: Up Remote Control Up
 - 19: Down Remote Control Down
 - 20: O/R Local Keypad Operation
 - 21: T/R Local Terminal Input Operator
 - 22: PIDIR PID Integral Reset
 - 23: PIDD PID Disabled
 - 24: FO Frequency Override
 - 25: RO Reset Override
 - 26: EXT2 External Trip 2
 - 27: EXT3 External Trip 3
 - 28: EXT4 External Trip 4
 - 29: EXT5 External Trip 5
 - 30: EXT6 External Trip 6
 - 31: UP/DOWN Initial Value Clear

- **C07~C012 Input Terminal Mode 1~6**
 - 0: Normally Open (NO)
 - 1: Normally Closed (NC)

- Set 0: Forward Run/Stop (FW)
- Set 1: Reverse Run/Stop (RV)

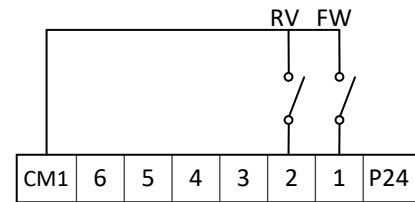

Code	Set Value	Description
A01	1	Frequency Command by Terminal Input
A02	1	Run Command by Terminal Input
C01	0	Set Terminal 1 to FW Operation
C02	1	Set Terminal 2 to RV Operation
C07	0	FW Operation: Terminal 1 to Normal Open When shorted(Closed); FW Run, When Open, FW Stop
C08	0	FW Operation: Terminal 1 to Normal Open When Shorted(Closed): FW Run; When Open, FW Stop

Caution



* If Terminal 1 and Terminal 2 are closed at the same time, VFD will stop
 ** If Run Connection and Command are set prior to the power up, as soon as power is on, motor will be running. Check if any command is set prior to the power is applied.

- Set 2: Multiple Speed Command 1 (CF1)
 - Set 3: Multiple Speed Command 2 (CF2)
 - Set 4: Multiple Speed Command 3 (CF3)
 - Set 5: Multiple Speed Command 4 (CF4)
- By combining CF4 ~ CF1, a frequency value can be selected From A11 ~ A25.

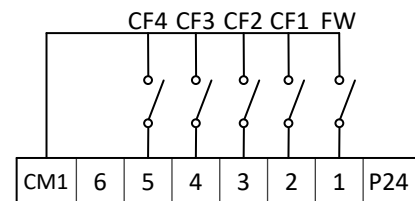

Code	Set Value	Description
A02	1	Run Command by Terminal Input
C01	0	Set Terminal 1 to FW Operation
C02	2	Set Terminal 2 to Multi Speed Command 1
C03	3	Set Terminal 3 to Multi Speed Command 2
C04	4	Set Terminal 4 to Multi Speed Command 3
C05	5	Set Terminal 5 to Multi Speed Command 4
C07~C11	0	Set Terminal 1 to 5 Normal Open When shorted(Closed); FW Run, When Open, FW Stop
F01	60	Set Output Frequency to 60Hz, but user programmable from 0 to 400 Hz
A11~A25	Hz	Program values for respective parameters. Refer to A Group.

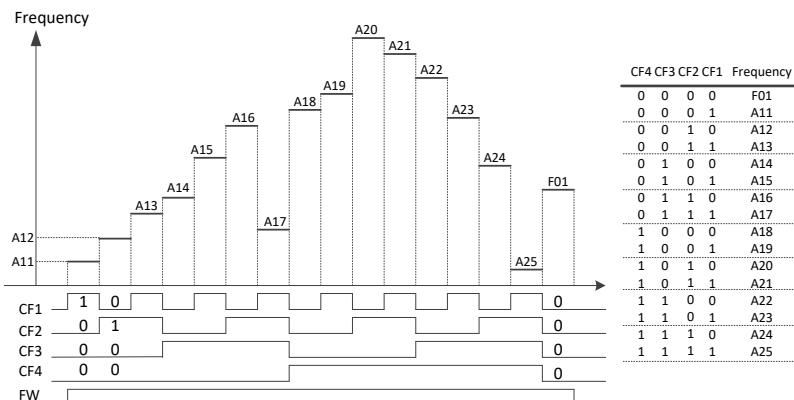

- Set 6: Jogging Operation Command (JG)**
 Jogging frequency is used to move/rotate the motor in small increment at low frequency.

Code	Set Value	Description
A02	1	Run Command by Terminal Input
C01	0	Set Terminal 1 to FW Operation
C03	6	Set Terminal 3 to JG Operation
C07	0	Set Terminal 1 to Normally Open When shorted(Closed); FW Run, When Open, FW Stop
C09	0	Set Terminal 3 to Normally Open
A26	[0.5~10Hz]	Jog Frequency Setpoint
A27	[0,1,2]	Jog Stop Mode (0:Free Run, 1: Deceleration, 2: DC Braking)

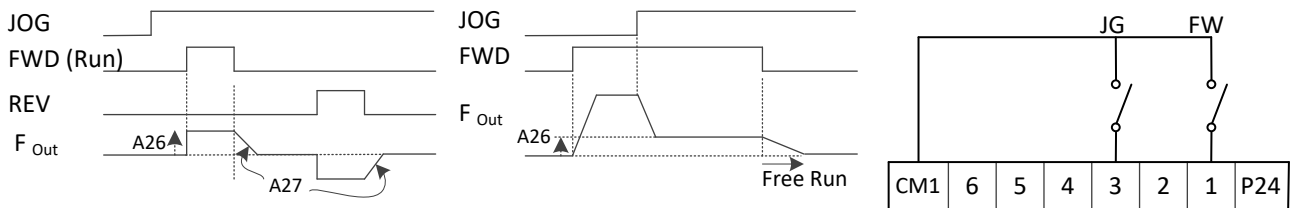

- Set 8: 2 Stage Acceleration/Deceleration (2CH)**
 By activating FRS command, second set of frequency acceleration and deceleration values can be selected.

Code	Set Value	Description
A02	1	Run Command by Terminal Input
C01	0	Set Terminal 1 to FW Operation
C05	6	Set Terminal 5 to 2CH Operation
C07	0	Set Terminal 1 to Normal Open When shorted(Closed); FW Run, When Open, FW Stop
C11	0	Set Terminal 5 to Normal Open
A54	[0.1~3000]	Acceleration Time 2
A55	[0.1~3000]	Deceleration Time 2
A56	0	Accel/Decel 2 Command Select to Terminal (if 1: use A57 & A58 F setpoint)
A57		Accel Time 2 Transition Frequency Setpoint
A58		Decel Time 2 Transition Frequency Setpoint

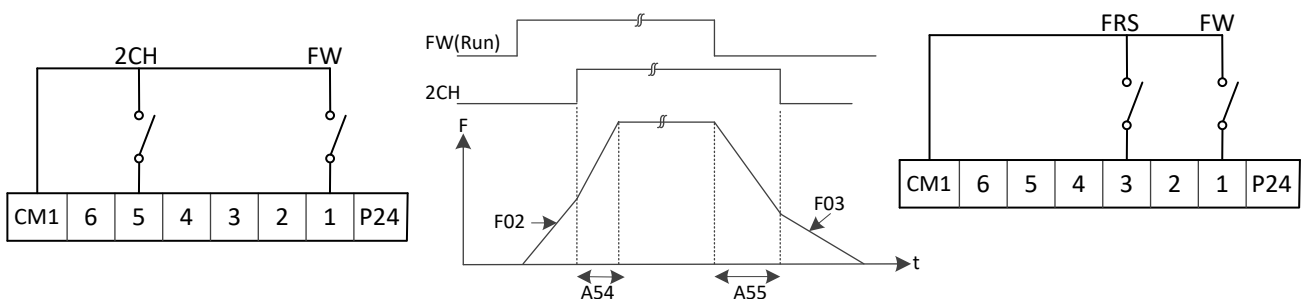

Set 9: Free Run Stop Command (FRS)

By activating FRS command, VFD stops the output and the motor coasts to stop.

Code	Set Value	Description
A02	1	Run Command by Terminal Input
C01	0	Set Terminal 1 to FW Operation
C03	9	Set Terminal 3 to FRS Operation
C07	0	Set Terminal 1 to Normal Open When shorted(Closed); FW Run, When Open, FW Stop
C09	0	Set Terminal 3 to Normal Open
b03	[0.1~10]	Delay Time to VFD Restart
b16	0	Restart Frequency Set to 0Hz on FRS Cancellation (1: Resume M-Fre)

i) When b16=0

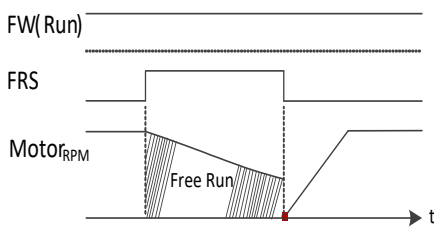

i) When b16=1

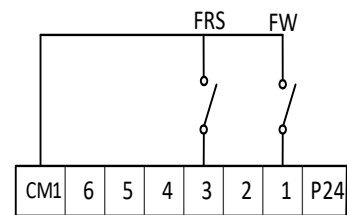
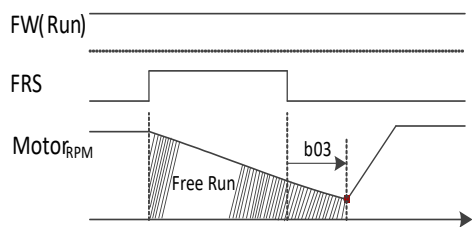

Set 10: External Trip 1 (EXT)

By asserting a trip signal, it forces the VFD to stop and generates E12. Even when EXT becomes inactive by opened the switch, the VFD remains the trip state. Thus, activating reset signal or recycle the power must be done to clear the error state.

Code	Set Value	Description
A02	1	Run Command by Terminal Input
C01	0	Set Terminal 1 to FW Operation
C03	10	Set Terminal 3 to FRS Operation
C07	0	Set Terminal 1 to Normal Open When shorted(Closed); FW Run, When Open, FW Stop
C09	0	Set Terminal 3 to Normal Open

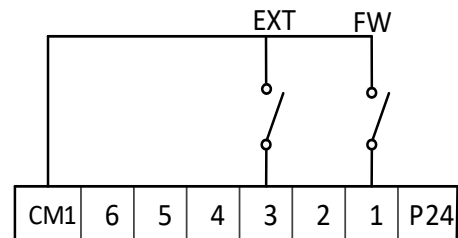
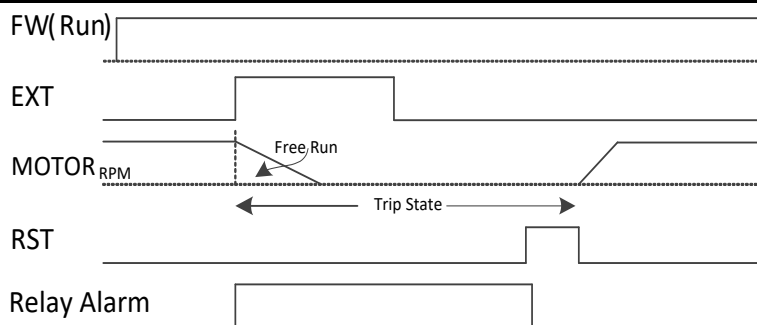

▪ **Set 11: Unintended Start Protection (USP)**

USP function is to prevent the automatic start up at power on. If the Run(FW/RV) command is activated prior to the power up, as soon as the power is applied, the VFD starts to run immediately. If USP is enabled, the VFD would not run till VFD is reset.

Code	Set Value	Description
A02	1	Run Command by Terminal Input
C01	0	Set Terminal 1 to FW Operation
C03	11	Set Terminal 3 to USP Operation
C07	0	Set Terminal 1 to Normal Open When shorted(Closed); FW Run, When Open, FW Stop
C09	0	Set Terminal 3 to Normal Open

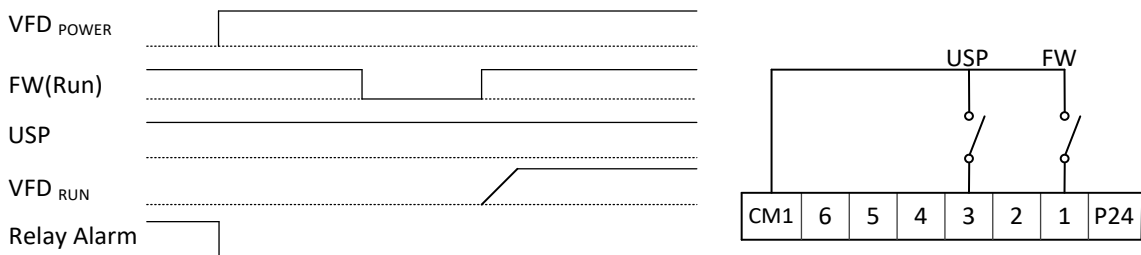

▪ **Set 12: Software Lock Function (SFT)**

Software lock function disables all the parameter value editing except b09

Code	Set Value	Description
A02	1	Run Command by Terminal Input
C01	0	Set Terminal 1 to FW Operation
C03	12	Set Terminal 3 to SFT Operation
C07	0	Set Terminal 1 to Normal Open When shorted(Closed): FW Run, When Open: FW Stop
C09	0	Set Terminal 3 to Normal Open

▪ **Set 13: Analog Input Current / Voltage Select (AT)**

If Shorted: Select Current Source
If Opened: Select Voltage Source

Code	Set Value	Description
A02	1	Run Command by Terminal Input
A01	1	Frequency Command by Terminal Input
C01	0	Set Terminal 1 to FW Operation
C05	13	Set Terminal 5 to AT Operation
C07	0	Set Terminal 1 to Normal Open
		When shorted(Closed), Select Current Source; When Open, Voltage Source
C11	0	Set Terminal 5 to Normal Open

Caution

* If A01 is programmed to 1, but AT is not assigned on the terminal, VFD uses internal algebraic sum of the voltage and the current inputs for the frequency value

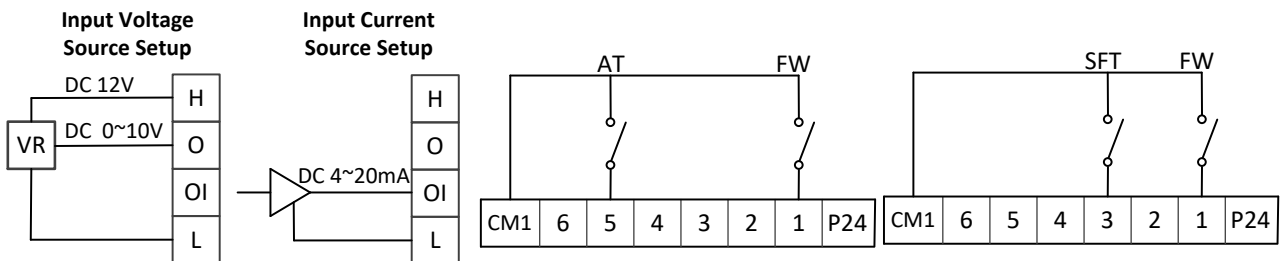

▪ **Set 14: Reset (RS)**

Code	Set Value	Description
A02	1	Run Command by Terminal Input
C01	0	Set Terminal 1 to FW Operation
C04	14	Set Terminal 4 to ST Operation
C07	0	Set Terminal 1 to Normal Open
		When shorted(Closed): FW Run, When Open: FW Stop
C10	0	Set Terminal 4 to Normal Open

Danger

*When Reset is asserted to clear the fault, if the RUN command is executed by FW/RV terminal set, the motor will immediately run to the speed. Be sure to set the RS after RUN command is disconnected in order to prevent



Caution

*If longer than 4 second is continued to be ON, E60, communication error will be displayed. Reset by disconnect RS terminal to OFF or press STOP/RESET Key and resume VFD operation to normal.



- **Set 15: Start (STA) 3 Wire Run/Stop Application**
- **Set 16: Keep (STP)**
- **Set 17: Forward / Reverse (F/R)**

Code	Set Value	Description
A02	1	Run Command by Terminal Input
C01	15	Set Terminal 1 to STA Operation
C02	16	Set Terminal 2 to STP Operation
C03	17	Set Terminal 3 to F/R Operation
C07	0	FW Operation: Terminal 1 to Normal Open When shorted(Closed): FW Run, When Open: FW Stop
C08	0	FW Operation: Terminal 2 to Normal Open
C09	0	FW Operation: Terminal 3 to Normal Open

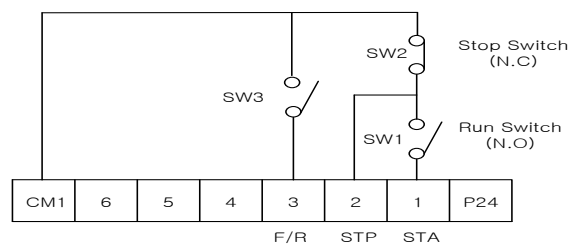

- **Set 18: Remote Control Up (UP)**
- **Set 19: Remote Control Down (DOWN)**
- **Set 31: Remote Control UP/Down Clear(UP/DN CLR)**

Code	Set Value	Description
A02	1	Run Command by Terminal Input
A01		Frequency Setting
C01	18	Set Terminal 1 to UP Operation
C02	19	Set Terminal 2 to Down Operation
C04	1	Set Terminal 3 to FWR Operation
C06	31	Set Terminal 6 to UP/DN CLR Operation
C07	0	FW Operation: Terminal 1 to Normal Open When shorted(Closed): FW Run, When Open: FW Stop
C08	0	FW Operation: Terminal 2 to Normal Open

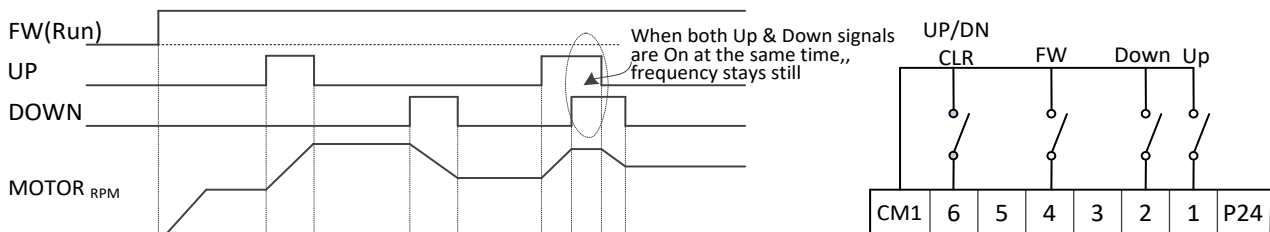

- **C28 UP/DOWN Initial Value Saving**

Selects if the Initial Value is going to be saved or not when power is removed.

- 0: Disabled
- 1: Enabled

- **C29 UP/DOWN Initial Value Setting**

- Range: 0.00 ~ Max Frequency(A04) in 0.01 Hz

Sets the UP/DOWN Initial Value. This value is then used as the starting frequency reference when the next Run Command is given. When U/D CLR signal input the terminal and UP or DOWN signal is open, UP/DOWN Initial Value is clear.

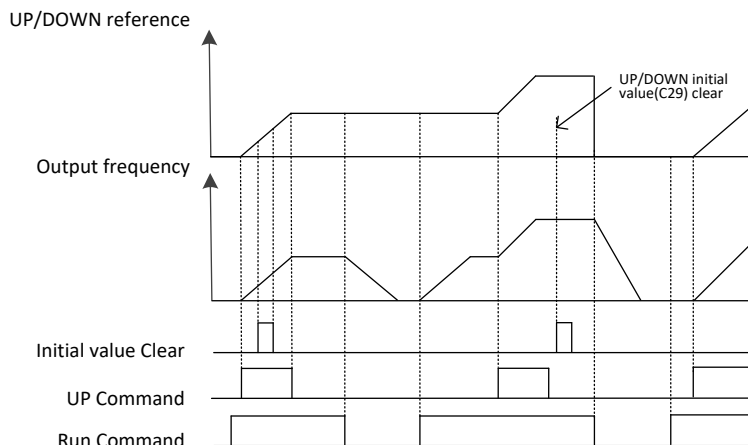

- **C30 UP/DOWN Reference Arriving Time**

- Range: 0.1 ~ 3000 Sec in 0.1 Sec

Sets the rate of change for the reference when this feature is applied.

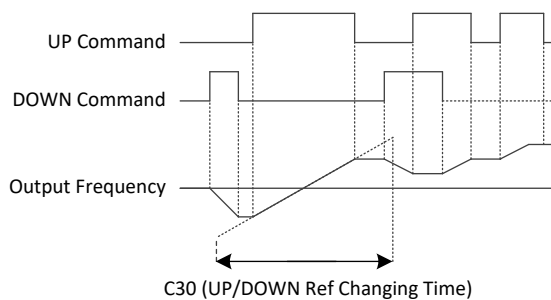

- **C31 UP/DOWN Enable Setting**

Enable or Disable target Frequency set by UP/DOWN function..

- 0: Disabled
- 1: Enabled

- **C32 UP/DOWN Reference Display**

Display the target Frequency set by UP/DOWN function..

- Range: 0.00 ~ 400.00 Hz in 0.01 Hz

- **Set 20: Local Keypad Override (O/R)**
- **Set 21: Local Terminal Override (T/R)**

Even when the frequency command (A01) and run command (A02) are set for VFD operation, Keypad (or local terminal input) can override these commands by activating these terminal bits.

Code	Set Value	Description
C01	20	Set Terminal 1 to O/R (Keypad Override)
C03	21	Set Terminal 3 to T/R (Terminal Override)
C07	0	FW Operation: Terminal 1 to Normal Open When shorted(Closed): FW Run, When Open: FW Stop
C09	0	FW Operation: Terminal 3 to Normal Open

Caution: If O/R and T/R switched on simultaneously, O/R has a priority than T/R. If switched on during VFD running, the VFD will stop and then operate by given command.

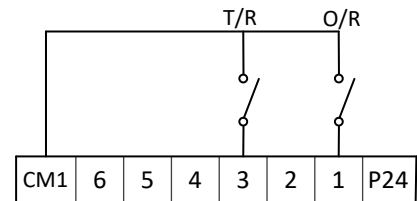

- **Set 22: PID Integral Reset Override (PIDIR)**
Even when the PID controller is activated, PIDIR can force resetting an accumulated integral term.

Code	Set Value	Description
C01	22	Set Terminal 1 to PIDIR
C07	0	FW Operation: Terminal 1 to Normal Open When shorted(Closed): FW Run, When Open: FW Stop
A70	1 or 2	PID Control or F/F Control

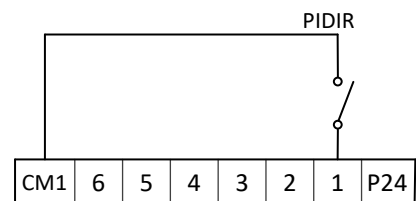

- **Set 23: PID Disabled (PIDD)**
Even when the PID controller is activated, PIDD can override disable the function. When PIDD becomes activated, VFD Frequency setpoint follows the value in A01.

Code	Set Value	Description
C01	22	Set Terminal 1 to PIDIR
C07	0	FW Operation: Terminal 1 to Normal Open When shorted(Closed): FW Run, When Open: FW Stop
A70	1 or 2	PID Control or F/F Control
A01		Frequency Command
F01	60	Output Frequency Setpoint

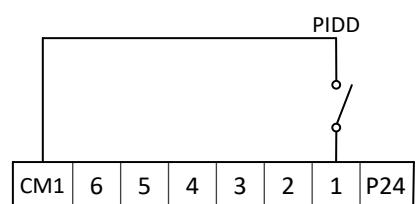
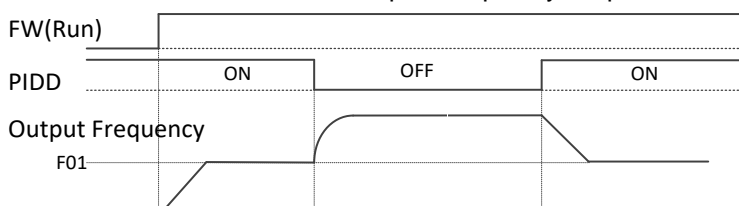

- **Set 24: Frequency Override (FO)**
- **Set 25: Reset Override (RO)**

Frequency Override is a manual frequency adder enables adding a frequency value to the target frequency setpoint. Since it is an edge triggered signal, it stays activated till Reset Override signal is provided. Once RO is activated, VFD frequency output follows back to the target value in F01.

Code	Set Value	Description
A02	1	Run command by Terminal Input
C01	0	Set Terminal 1 to Forward Run
C05	24	Set Terminal 5 to Manual Frequency Adder
C06	25	Set Terminal 6 to Reset Override
C07	0	Terminal 1 to Normal Open When Shorted(Closed): FW Run, When Open: FW Stop
C11	0	Terminal 5 to Normal Open
C12	0	Terminal 6 to Normal Open
F01	[0.5 ~ Max Hz]	Output Frequency Setting
A11	[0.5 ~ F04 Hz]	1st Multi Speed Frequency (Shared with this function)

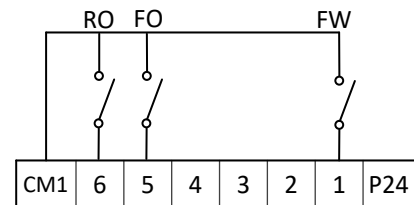
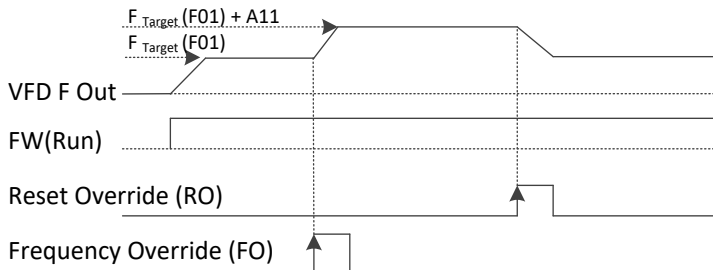

- **Set 26: External Trip 2 (EXT2)**
- **Set 27: External Trip 3 (EXT3)**
- **Set 28: External Trip 4 (EXT4)**
- **Set 29: External Trip 5 (EXT5)**
- **Set 30: External Trip 6 (EXT6)**

In addition to External Trip in Set 10, five more external trip signals are provided for flexible control of corresponding function.

Code	Set Value	Description
C01	1	Run command by Terminal Input
C02	26	Set Terminal 2 to External Trip 2
C03	27	Set Terminal 3 to External Trip 3
C04	28	Set Terminal 4 to External Trip 4
C05	29	Set Terminal 5 to External Trip 5
C06	30	Set Terminal 6 to External Trip 6
C07~C12	0	Terminal 1~6 Normal Open When Shorted(Closed): FW Run, When Open: FW Stop

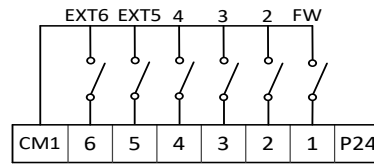
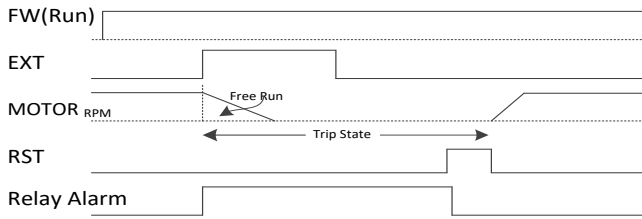

OUTPUT

• C13 Output Relay 1 (AL0, AL1, AL2)

Program one of following output command

- 0: RUN VFD Run Signal
- 1: FA1 Frequency Arrival 1
- 2: FA2 Frequency Arrival 2
- 3: OL Overload Warning Signal
- 4: OD Output Deviation Excess for PID Control
- 5: AL Fault Signal
- 6: COM Operation by Communication
- 7: SOD System Overload Detection
- 8: SUD System Underload Detection
- 9: SOD/SUD System Overload/Underload Detection
- 10: AI_LOSS Analog Input Loss Detection
- 11: KEY_LOSS Keypad Information Loss Detection
- 12: BRK Control external braking

If C13 = 0: When VFD is not Running
 If C13 = 1: When Frequency is not Arrival 1
 If C13 = 2: When Frequency is not Arrival 2
 If C13 = 3: When Overload condition isn't occurred
 If C13 = 4: When PID Error does not Exceed the Set Level
 If C13 = 5: No fault condition is occurred
 If C13 = 6: When it is not operated by modbus
 If C13 = 7: When System Overload is not detected
 If C13 = 8: When System Underload is not detected
 If C13 = 9: When System Overload and Underload are not detected

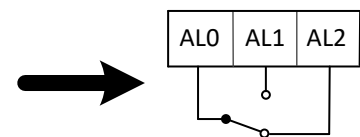

If C13 = 0: When VFD is Running
 If C13 = 1: When Frequency is at Arrival 1
 If C13 = 2: When Frequency is at Arrival 2
 If C13 = 3: When Overload condition occurred
 If C13 = 4: When PID Error does Exceed the Set Level
 If C13 = 5: Fault condition is occurred
 If C13 = 6: When it is operated by modbus
 If C13 = 7: When System Overload is detected
 If C13 = 8: When System Underload is detected
 If C13 = 9: When System Overload and Underload are detected
 If C13 = 10: When Analog Input Loss Detection
 If C13 = 11: When Keypad Information Loss Detection
 If C13 = 12: When Control external braking

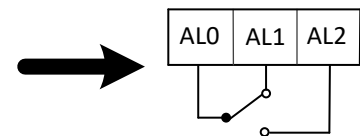

- **C14 Output Relay 2 (RN0-RN1)**
 - **C15 Output Relay 3 (RN2-RN3)**
 - Program one of following output command below. These intelligent relay out terminals can be configured to Form A or B type by programming C16 and C17 to 0 or 1.
 - 0: RUN VFD Run Signal
 - 1: FA1 Frequency Arrival 1
 - 2: FA2 Frequency Arrival 2
 - 3: OL Overload Warning Signal
 - 4: OD Output Deviation Excess for PID Control
 - 5: AL Fault Signal
 - 6: COM Operation by Communication
 - 7: SOD System Overload Detection
 - 8: SUD System Underload Detection
 - 9: SOD/SUD System Overload/Underload Detection
 - 10: AI_LOSS Analog Input Loss Detection
 - 11: KEY_LOSS Keypad Information Loss Detection
 - 12: BRK Control external braking
- **C16~C17 Output Relay 2, 3 (RN0-RN1, RN2-RN3) Mode**
 - 0: Normally Open (NO) – Form A Configuration
 - 1: Normally Closed (NC) – Form B Configuration

Contact specification

Maximum	Minimum
AC250V, 2.5A(Resistor load), 0.2A(Inductive load)	AC100V, 10mA
DC30V, 3.0A(Resistor load), 0.7A(Inductive load)	DC5V, 100mA

- **Set 0: RUN**
Even when the PID controller is activated, PIDD can override disable the function. When PIDD becomes activated, VFD Frequency setpoint follows the value in A01.

Code	Set Value	Description
C13	0	Set Intelligent Relay Out 1 Terminal to RUN Mode
C14	0	Set Intelligent Single Pole Single Throw (SPST) Relay Out Terminal to RUN Mode
C16	0	Set C14 to Normally Open to Form A configuration If set to 1, Form B configuration (Normally Closed)

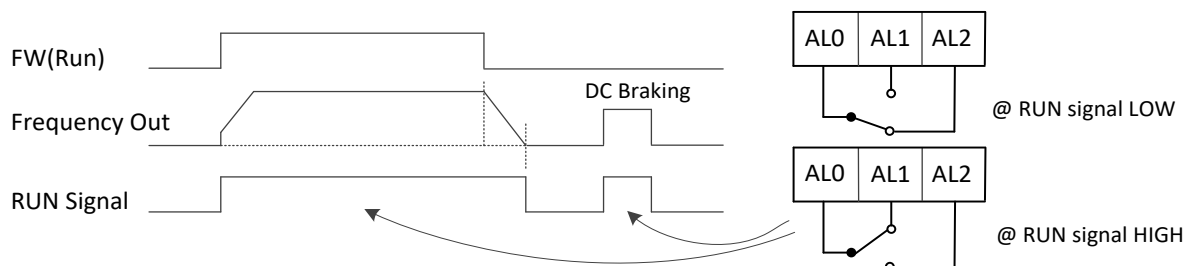

- **Set 1:** Frequency Arrival Signal 1 (FA1)
- **Set 2:** Frequency Arrival Signal 2 (FA2)

Frequency Arrival signals indicate if the VFD output frequency reaches the set frequency specified in F01. FA1 (FA2) becomes triggered active from 0.5Hz lower set frequency value during acceleration and 1.5Hz lower during deceleration. But there is 60mS of delay time from the beginning of its activation.

Code	Set Value	Description
C13	1	Set Intelligent Relay Out 1 Terminal to FA1
C15	0	Set C13 to Normally Open to Form A configuration If set to 1, Form B configuration (Normally Closed)
F01	0~ Max F	VFD Out Target Frequency
C22	[0 ~ A04] Hz	Target Frequency Setpoint during Acceleration for Frequency Arrival Signal
C23	[0 ~ A04] Hz	Target Frequency Setpoint during Deceleration for Frequency Arrival Signal

Output frequency[Hz]

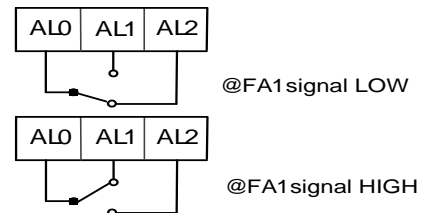
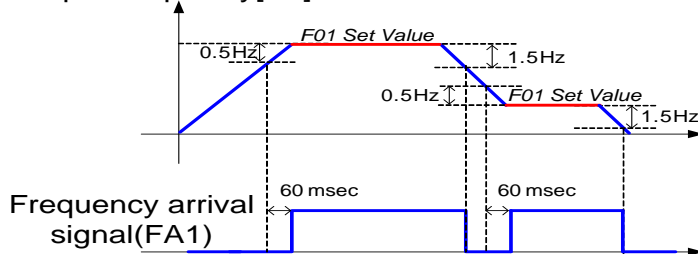

Output frequency[Hz]

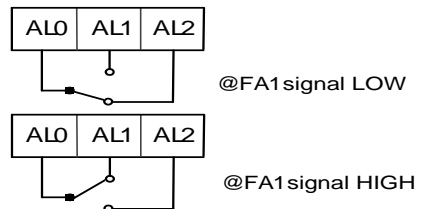
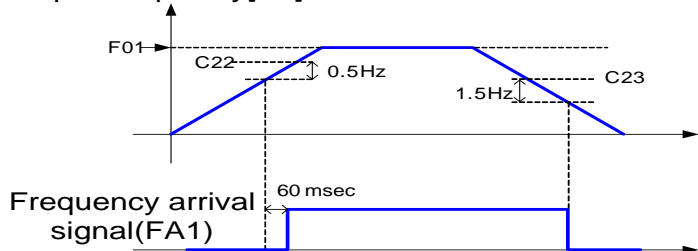

▪ **Set 3: Overload Advanced Notice Signal (OL)**

Before the VFD becomes overload, iMaster C1 generates an advanced warning signal to prevent any damage by the excessive output current. Overload detection circuit is designed to operate during powered motor operation and regenerative braking operation. The OL signal becomes ACTIVE High when the output current exceeds the setpoint programmed in C21, Overload Advance Notice Signal Setting

Code	Set Value	Description
C13	3	Set Intelligent Relay Out 1 Terminal to OL
C16	0	Set C13 to Normally Open to Form A configuration If set to 1, Form B configuration (Normally Closed)
C21	[10~200] %	Overload Advanced Notice Signal Setting; % x VFD rated current
C40	[0.0~30.0] s	Detection time of overload advance notice signal level

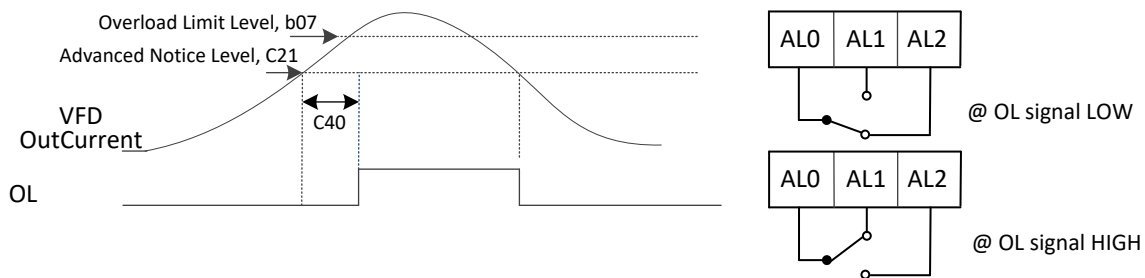

▪ **Set 4: Output Deviation Excess for PID Control (OD)**

The PID loop error is defined as the magnitude of the difference between the set point and process variable. When the error magnitude exceeds the value of C24, the OD terminal signal turns on

Code	Set Value	Description
C13	3	Set Intelligent Relay Out 1 Terminal to OD
C16	0	Set C13 to Normally Open to Form A configuration If set to 1, Form B configuration (Normally Closed)
C24	[0.0~100] %	PID Deviation level Setting

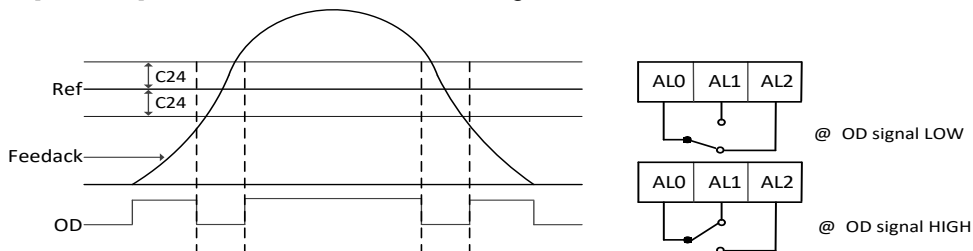

▪ **Set 5: Alarm Signal (AL)**

The inverter fault signals is active when a fault has occurred

Code	Set Value	Description
C13	3	Set Intelligent Relay Out 1 Terminal to AL
C16	0	Set C13 to Normally Open to Form A configuration If set to 1, Form B configuration (Normally Closed)

- Set 6: Operation by Communication (COM)**
 The digital outputs can be controlled by modbus communication

Parameter	Address	Description
Digital Output (Relay Output)	0x1001	Refer to below bit table 0: Stop Write Command has to set C13~C16 = 6

Digital Output Bit Table

1st byte

Bit7	Bit6	Bit5	Bit4	Bit3	Bit2	Bit1	Bit0
Reserved							

2nd byte

Bit7	Bit6	Bit5	Bit4	Bit3	Bit2	Bit1	Bit0
Reserved					AL0~2	RN2~3	RN0~1

- Set 7: System Overload Detection (SOD)**
 The inverter System Overload is active by b57 level

Code	Set Value	Description
C13	7	Set Intelligent Relay Out 1 Terminal to SOD
C16	0	Set C13 to Normally Open to Form A configuration If set to 1, Form B configuration (Normally Closed)
b56	1 or 4 or 6	System Overload Detection or Detection with Fault (E23)
b57	[20~200] %	System Overload Detection Level

System Overload Detection

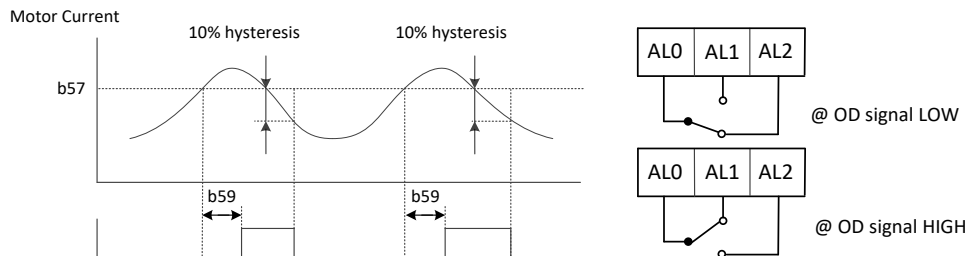

- **Set 8: System Underload Detection (SUD)**
The inverter System Underload is active by b58 level

Code	Set Value	Description
C13	8	Set Intelligent Relay Out 1 Terminal to SUD
C16	0	Set C13 to Normally Open to Form A configuration If set to 1, Form B configuration (Normally Closed)
b56	2 or 5 or 6	System Underload Detection or Detection with Fault (E24)
b58	[20~200] %	System Underload Detection Level

System Underload Detection

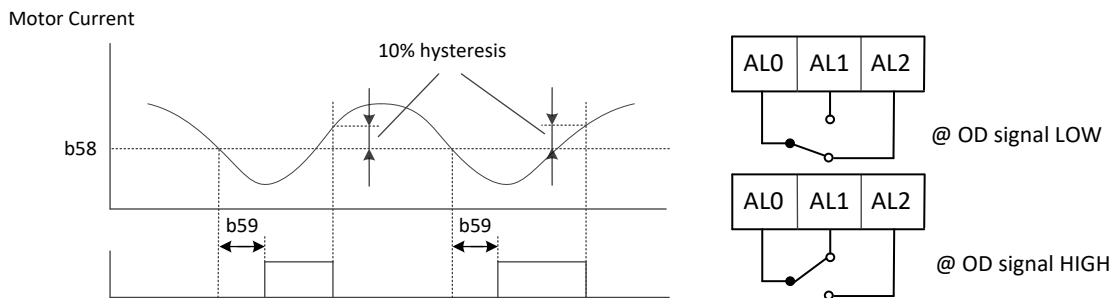

- **Set 9: System Overload/Underload Detection (SOD/SUD)**
The inverter System Overload/Underload is active by the each(b57, b58) level

Code	Set Value	Description
C13	9	Set Intelligent Relay Out 1 Terminal to SOD/SUD
C16	0	Set C13 to Normally Open to Form A configuration If set to 1, Form B configuration (Normally Closed)
b56	6	System Underload/Overload Detection with Fault (E23, E24)
b57	[20~200] %	System Underload Detection Level
b58	[20~200] %	System Underload Detection Level

- **Set 10: Analog Input Loss Detection (AI_LOSS)**
The inverter System Analog Input Loss detection is active by the each(C36~C39) value

Code	Set Value	Description
C13	10	Set Intelligent Relay Out 1 Terminal to AI_LOSS
C16	0	Set C13 to Normally Open to Form A configuration If set to 1, Form B configuration (Normally Closed)
C36	1	Loss frequency (50%) (Less than 50% of A07)
C37	2	Selection of run command when speed losing(Deceleration stop)
C38	[0~120] Sec	Waiting time in case of frequency command loss
C39	[0~A04] Hz	Frequency setting in case of analog command loss

- Set 11: Keypad Information Loss Detection (KEY_LOSS)**
 The inverter Keypad Information Loss detection is active by the each(C33~C35) value

Code	Set Value	Description
C13	11	Set Intelligent Relay Out 1 Terminal to KEY_LOSS
C16	0	Set C13 to Normally Open to Form A configuration If set to 1, Form B configuration (Normally Closed)
C33	[0~6000] Sec	Decel time at fault occur
C34	1	Selection of running state when keypad connection failed(Stop)
C35	1	Selection of keypad detection(Abnormal move detection)

- Set 12: Control external braking (BRK)**
 The inverter external braking Control is active by the each(C41~C45) value

Code	Set Value	Description
C13	12	Set Intelligent Relay Out 1 Terminal to BRK
C16	0	Set C13 to Normally Open to Form A configuration If set to 1, Form B configuration (Normally Closed)
C41	[0~200] %	Current of external brake
C42	[0~25] Hz	Frequency of external brake
C43	[0~5] Sec	Timer of external brake
C44	[0~25] Hz	Stop frequency of external brake
C45	[0~5] Sec	Stop timer of external brake

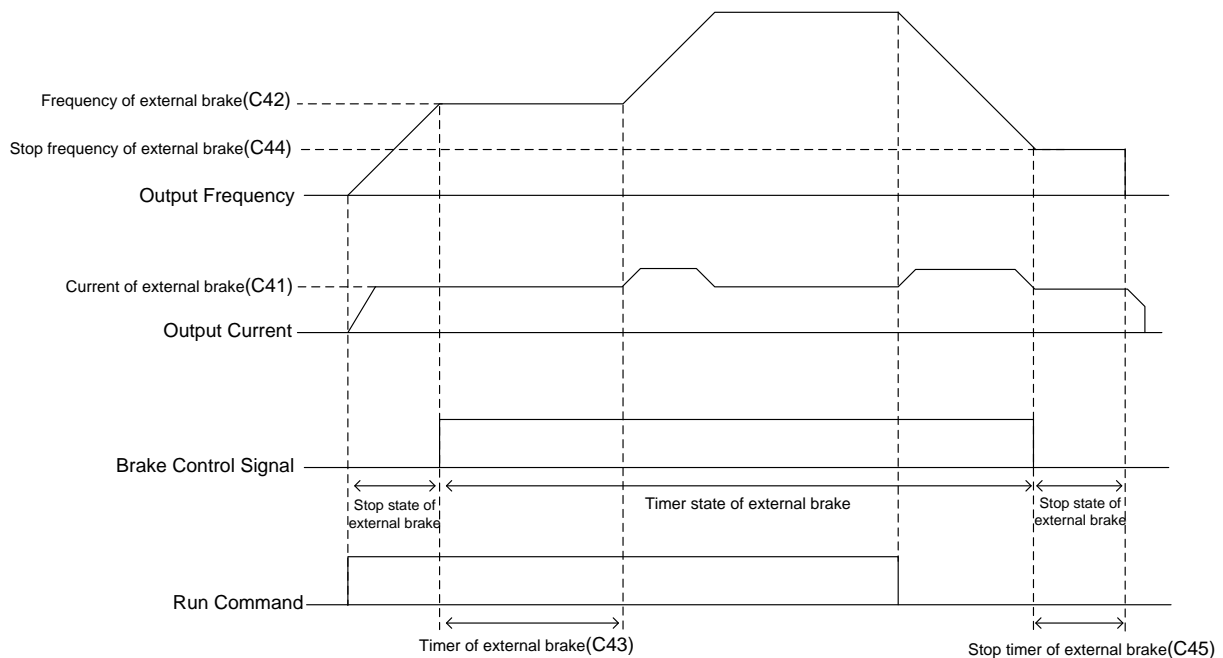

- **C18 FM Output Setting**

Program what output performance to be monitored from following selections

- 0: Output Frequency Monitor
- 1: Output Current Monitor
- 2: Output Voltage Monitor
- 3: Output Power Monitor
- 4: Output Torque Monitor
- 5: Operation by Communication
- 6: DC voltage

- **Set 0: Output Frequency Monitor**
Monitor the VFD output frequency value. The highest analog output value is the maximum frequency value. The indicator accuracy after the adjustment is about +/- 5%.
- **Set 1: Output Current Monitor**
Monitor the VFD output current value. The highest analog value is the 200% of rated VFD current. The indicator accuracy after the adjustment is about +/- 10%.
- **Set 2: Output Voltage Monitor**
Monitor the VFD output voltage value. The highest analog value is the 100% of rated VFD voltage out. The indicator accuracy after the adjustment is about +/- 10%.
- **Set 3: Output Power Monitor**
Monitor the VFD output power value. The highest analog value is the 200% of rated VFD power out. The indicator accuracy after the adjustment is about +/- 10%.
- **Set 4: Output Torque Monitor**
Monitor the VFD output torque value. The highest analog value is the 150% of rated VFD output torque. The indicator accuracy after the adjustment is about +/- 10%

FM output	Torque
0V	-150%
5V	0%
10V	+150%

- **Set 5: Operation by Communication**
It can control FM output value (0~10V) by Modbus command

Parameter	Address	Description
Analog Output (FM)	0x1004	0 ~ 10000 (0.1 scale, 0 ~ 10V, 0 ~ 100%) Write Command has to set C18 = 5

Digital Output Bit Table

1st byte

Bit7	Bit6	Bit5	Bit4	Bit3	Bit2	Bit1	Bit0
Reserved							

2nd byte

Bit7	Bit6	Bit5	Bit4	Bit3	Bit2	Bit1	Bit0
Reserved					AL0~2	RN2~3	RN0~1

- **Set 6: DC voltage Monitor**
Monitor the VFD DC voltage value. The highest analog value is the 100%(400/800Vdc) of rated VFD DC voltage. The indicator accuracy after the adjustment is about +/- 10%.

- **C19 FM Gain**
 - Range: 0.0 ~ 250.0 % in 0.1
Program the gain factor to FM motoring setting
- **C20 FM Offset**
 - Range: -3.0 ~10.0 % in 0.1
Program the offset factor to FM monitoring setting
- **C21 Motor Overload Alarm**
 - Range: 10.0 ~200.0 % in 0.1
Program a level of the rated motor current
- **C22 FA2 SetPoint at Acceleration**
 - Range: 0.00 ~ A04 Hz in 0.01
Program the frequency arrival threshold during acceleration
- **C23 FA2 SetPoint at Deceleration**
 - Range: 0.00 ~A04 Hz in 0.01
Program the frequency arrival threshold during deceleration
- **C24 PID Error Tolerance**
 - Range: 0.0 ~100.0 % in 0.1
Program the allowable PID loop error magnitude

- **C25 AMI Output Setting**

Program what output performance to be monitored from following selections

- 0: Output Frequency
 - 1: Output Current
 - 2: Output Voltage
 - 3: Output Power
 - 4: Output Torque Monitor
 - 5: Operation by Communication
 - 6: DC voltage
- **Set 0: Output Frequency Monitoring**
Monitor the VFD output frequency value. The highest analog output value is the maximum frequency value. The indicator accuracy after the adjustment is about +/- 5%.
 - **Set 1: Output Current Monitoring**
Monitor the VFD output current value. The highest analog value is the 200% of rated VFD current. The indicator accuracy after the adjustment is about +/- 10%.
 - **Set 2: Output Voltage Monitoring**
Monitor the VFD output voltage value. The highest analog value is the 100% of rated VFD voltage out. The indicator accuracy after the adjustment is about +/- 10%.
 - **Set 3: Output Power Monitoring**
Monitor the VFD output power value. The highest analog value is the 200% of rated VFD power out. The indicator accuracy after the adjustment is about +/- 10%
 - **Set 4: Output Torque Monitor**
Monitor the VFD output torque value. The highest analog value is the 150% of rated VFD output torque. The indicator accuracy after the adjustment is about +/- 10%

AMI output	Torque
4mA	-150%
12mA	0%
20mA	+150%

- **Set 5: Operation by Communication**

It can control AMI output value(4~20mA) by Modbus command

Parameter	Address	Description
Analog Output (AMI)	0x1005	0 ~ 10000 (0.1 scale, 4 ~ 20mA, 0 ~ 100%) Write Command has to set C25 = 5

Digital Output Bit Table

1st byte

Bit7	Bit6	Bit5	Bit4	Bit3	Bit2	Bit1	Bit0
Reserved							

2nd byte

Bit7	Bit6	Bit5	Bit4	Bit3	Bit2	Bit1	Bit0
Reserved					AL0~2	RN2~3	RN0~1

- **Set 6: DC voltage Monitor**

Monitor the VFD DC voltage value. The highest analog value is the 100%(400/800Vdc) of rated VFD DC voltage. The indicator accuracy after the adjustment is about +/- 10%.

- **C26 AMI Gain**

- Range: 0.0 ~ 250.0 % in 0.1
Program the gain factor to AMI motoring setting

- **C27 AMI Offset**

- Range: -99.9 ~ 100.0 % in 0.1
Program the offset factor to AMI monitoring setting

- **C46 Changed function code display function**

User can check the changed function code lists at function code C46 (based on default). Set C46 to 1 then it displays the changed function code lists and check the code lists using up/down button in operator

- 0: Disabled
- 1: Display changed function code lists
 - Display the changed function code lists which changed from the default value. Check the changed function code and possible to change the data

5.7 H Group Parameters

iMaster C1 VFD offers Sensorless Vector control, enabling high starting torque and high precision operations. Motor data required for Sensorless Vector control design can be selected from standard motor data or auto-tuning algorithm. If VFD size is more than twice the motor size, the required torque characteristics or speed control characteristics are not well controlled.

- **H01 Auto Tuning**

- 0: Disabled
- 1: Enabled

Program to enable auto tuning function. Motor parameters are calculated using the internal auto tuning algorithm and automatically set for Sensorless Vector control design.

❖ Related Parameters: A31 (2: Sensorless Vector Control)

- **H02 Motor Data Select**

- 0: Standard Motor Data
- 1: Auto Tuning Data

Program to select between standard motor data and auto tuned motor data.

❖ Related Parameters:

- **H03 Motor Capacity**

0.4L:220V/0.4kW(0.5HP)	0.4H:380V/0.4kW(0.5HP)
0.7L:220V/0.7kW(0.9HP)	0.7H:380V/0.7kW(0.9HP)
1.5L:220V/1.5kW(2HP)	1.5H:380V/1.5kW(2HP)
2.2L:220V/2.2kW(3HP)	2.2H:380V/2.2kW(3HP)
3.7L:220V/3.7kW(5HP)	3.7H:380V/3.7kW(5HP)
5.5L:220V/5.5kW(7.5HP)	5.5H:380V/5.5kW(7.5HP)
7.5L:220V/7.5kW(10HP)	7.5H:380V/7.5kW(10HP)
11L:220V/11kW(15HP)	11H:380V/11kW(15HP)
15L:220V/15kW(20HP)	15H:380V/15kW(20HP)
18.5L:220V/18.5kW(25HP)	18.5H:380V/18.5kW(25HP)
22L:220V/22kW(30HP)	22H:380V/22kW(30HP)
30L:220V/30kW(40HP)	30H:380V/30kW(40HP)

Program the corresponding iMaster C1 model used for the current application.

❖ Related Parameters:

- **H04 Motor Poles Setting**

- 2~48
- 2 Poles for 3600 RPM (60 Hz), 3000 RPM (50 Hz)
- 4: 4 Poles for 1800 RPM (60 Hz), 1500 RPM (50 Hz)
- 48: 48 Poles for 150 RPM (60 Hz), 125 RPM (50 Hz)

Program a number of poles to the corresponding motor used with the VFD.

❖ Related Parameters:

- **H05 Motor Rated Current**

- Range: 0.1 ~ 800.0 A in 0.1 A
- Program a rated current off of the motor nameplate (Motor FLA)
- ❖ Related Parameters:

- **H06 Motor Flux Current**
 - Range: 0.1 ~ 400.0 A in 0.1 A
Program the no load (flux) current value. Not all motors will have this information on the nameplate.
 - ❖ Related Parameters:

- **H07 Motor Rated Slip**
 - Range: 0.01 ~ 20.0 Hz in 0.1 Hz
Program the slip percent of the motor rated nameplate rpm.
ie- $[(1800 \text{ rpm} - 1750 \text{ rpm})] * (4\text{pole}/120) = 1.67\text{Hz}$
 - ❖ Related Parameters:

- **H08 Motor Resistance R1**
 - Range: 0.1 ~ 3000.0 mOhms in 0.1 mOhms
Hyundai motor data
 - ❖ Related Parameters:

- **H09 Transient Inductance**
 - Range: 0.001 ~ 30.000 mH in 0.001 mH
Hyundai motor data
 - ❖ Related Parameters:

- **H10 Motor Resistance R1 Auto Tuning Data**
 - Range: : 0.1 ~ 3000.0 mOhms in 0.1 mOhms
Value determined during Auto Tuning process
 - ❖ Related Parameters:

- **H11 Transient Inductance Auto Tuning Data**
 - Range: 0.001 ~ 30.000 mH in 0.001 mH
Value determined during Auto Tuning process

- **H12 State of Auto-tuning**
Display value determined during Auto Tuning process

***Auto Tuning Application

Setting Procedures

- H02:
- H03:
- H04:
- H05:
- H06
- H07

Execution: Press "Run" Key

Successful Completion ; --oK (if failed: Err on display)

- H01: Select the latest to 1

Auto Tuning

Function description

The auto tuning procedure automatically sets the motor parameters related to sensorless vector control and automatic torque boost. Since these functions are dependent upon specific motor parameters, default motor parameters have been set at the factory.

An auto tune is recommended before running in sensorless vector or automatic torque boost mode in order to achieve optimal performance

Auto-Tune Procedure

Follow the steps below to auto tune the inverter, finally set the parameter H01.

1. F02, F03: Set to 30 s, the default for each parameter
2. H03: Set the motor rating
3. H04: Set the motor poles
4. A01: Set to 0 (frequency command source at potentiometer)
5. A03: Set the base frequency (default is 60Hz)
6. F01: Set the target frequency to 0Hz by turning the potentiometer all the way down. Verify this setting by looking at the value in F01.
7. A53: Select the output voltage to the motor.
8. A33: Set to 0 (disables DC injection braking).
9. H01: Set to 1 (turns auto tuning mode on).
10. After setting above parameters, press the RUN key on the standard operator.
11. The VFD will run the auto tuning procedure on the motor. During this procedure the motor may run up to 80% of full speed. During the auto tune you will see the following messages on the screen:



12. When you see the last screen ($--OP^U$, for "OK") the auto tune has successfully completed.
 - a. If the display shows Err instead, the auto tune has failed. Verify that the motor is wired properly
13. H02: Set to 1 (uses auto tune data)

Auto Tuning method

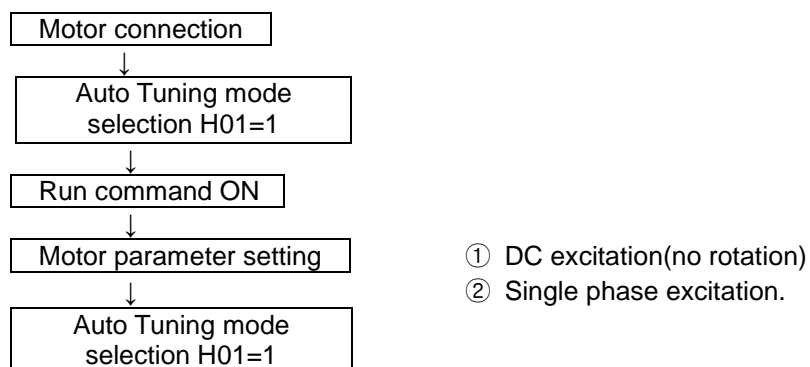

End display

Auto Tuning process completed : $_ _ 01^{\mu}$

Auto Tuning process failed : $_ _ Err$

Note : The default motor parameters of the iMaster C1 use standard data of a HYUNDAI 4-pole motor.
If using sensorless vector or auto-torque boost with a different motor type, use the auto tune feature to set the motor data.

Fine Tuning

1. If satisfactory performance through auto tuning cannot be fully obtained, adjust the motor constants for the observed symptoms according to the table below.

Symptom		Adjustment	Parameter
At Motoring Status	When low frequency (a few Hz) torque is insufficient.	Slowly increase the motor constant 1.2 times the auto tune data.	H08/H10
	When the speed deviation is negative.	Slowly increase the rated motor slip up to 1.5 times original setting.	H07
	When the speed deviation is positive.	Slowly decrease the rated motor slip down to 0.5 times original setting	H07
	When Over current Fault occurs as the load is applied	Slowly increase the motor no load current in up to 1.2 times original setting.	H06
At Regeneration Status	When low frequency (a few Hz) torque is insufficient.	Slowly increase the motor constant R1 1.2 times the auto tune data	H08/H10
		Slowly increase the motor no load current in up to 1.2 times original setting	H06
		Decrease the carrier frequency.	b11

2. If the inverter capacity is more than twice the capacity of the motor in setting of A28=1, A31=2, the VFD may not achieve its full performance specifications.
3. When DC injection braking is enabled (A33 = 1), the motor constant will not be accurately set. Therefore, disable DC injection braking (A33 = 0) before starting the auto tuning procedure.
4. The motor and load must be stationary before initiating the auto tune. Auto tuning while the motor is rotating may produce inaccurate results.
5. If the auto tuning procedure is interrupted by the stop command, the auto tuning constants may be stored in the inverter incorrectly. It will be necessary to reset the inverter to factory defaults (b12 = 1 *NOTE: This will reset all inverter parameter back to the factory

6. COMMUNICATION

iMaster C1 offers two communication interfaces between the inverter and external controller through RS485. Use RJ-45 modular connector and RXP, PXN as second way. By communication, the main controller (iMaster C1) can control 1~32 pcs controllers as slave.

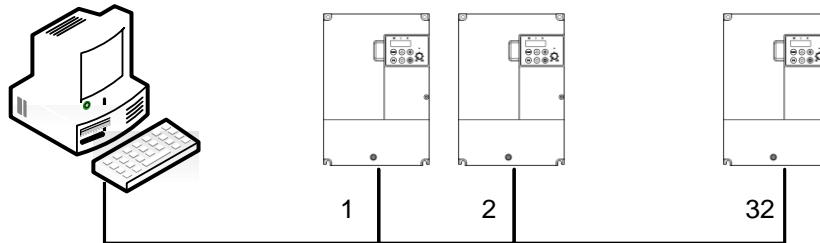

RS 485 Serial Network

Figure 6-1 RS485 Serial Communication Network

■ RS485 Communication specification

Item	Description	Remark
Interface	RS485	
Communication method	Half duplex	
Communication speed	9600 (1 st RJ-45) 2400~38400 (2 nd terminal)	Fixing Changeable setting(b31)
Communication code	Binary code	
Date bit	8	Fixing
Parity	No	Fixing
Stop bit	1	Fixing
Starting method	External request	Inverter is only slave part
Wait time	10~1000ms	
Connection type	1: N (Max 32) (Note1)	
Error check	Frame/CRC/CMD/MAXREQ/Parameter	Communication number is selected at b17

(Note 1) Depending on the installation environment, there is a high probability of communication malfunction due to wiring type, wiring method, and other noise. For reliable communication, we recommend fewer than 16 connections.

■ RJ45 specification (1st Communication)

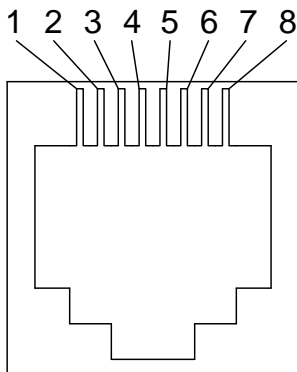

Pin No.	Signal Descriptions
1	
2	
3	RS - 485+
4	
5	
6	RS - 485-
7	24V
8	24V GND

■ Terminal specification (2nd communication)

Name	Description
RXP	RS485 (+)
RXN	RS485 (-)

■ RS485 related code

Func-code	Range	Default	Setting
b17	1 ~ 32	1	Setting communication number
b31	1 – 2400 [bps] 2 – 4800 [bps] 3 – 9600 [bps] 4 – 19200 [bps] 5 – 38400 [bps]	3	Setting 485 and 2 nd communication speed
A01	0 – Keypad potentiometer 1 – Control input terminal 2 – Standard operator 3 – Remote (1 st communication RJ45) 4 – Remote (2 nd communication Terminal) 5 – Option 6 – Potentiometer and remote	1	
A02	0 – Keypad potentiometer 1 – Control input terminal 2 - Remote (1 st communication RJ45) 3 – Remote 2 nd communication Terminal) 4 – Fieldbus (option)	1	

■ **Communication sequence**

The communication sequence is as follows,

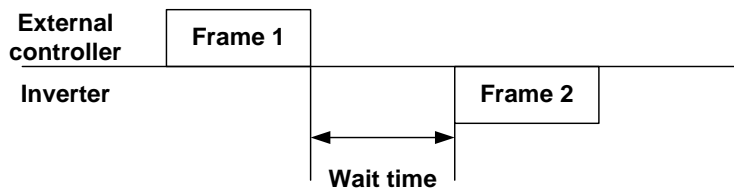

Frame start: Frame start is recognized by signal line data transmitted.

Frame completion: Frame completion is recognized by no data during correspond 4, 5-character time.

Frame 1: Transmit from external controller to inverter.

Frame 2: Indication reflects from inverter to external controller

■ **Communication frame type and form**

● **External controller transmit frame**

Communication number	Command	Parameter	Parameter count	CRC Hi	CRC Lo
----------------------	---------	-----------	-----------------	--------	--------

	Description	Data size	Specifications
Communication number	Inverter communication number	1 byte	1~32
Command	Frame type	1 byte	0x03
Parameter	Parameter	2 bytes	1 st byte: Group 2 nd byte: Index
Parameter count	Request parameter number(count)	2 bytes	1 st byte: 0x00 2 nd byte: N(0x01~0x08)
CRC Hi	-	1 byte	Higher 8bit of 16bit CRC
CRC Lo	-	1 byte	Lower 8bit of 16bit CRC

● **Inverter response frame**

Communication number	Command	Byte Number	Data 1	...	Data N	CRC Hi	CRC Lo
----------------------	---------	-------------	--------	-----	--------	--------	--------

	Description	Data size	Specifications
Communication number	Inverter communication number	1 byte	1~32
Command	Frame type	1 byte	0x03
Byte Number	Data Byte Number	1 byte	Request parameter * 2
Data 1	Parameter 1	2 bytes	Parameter value
Data N	Parameter N	2 bytes	Nth parameter value
CRC Hi	-	1 byte	Higher 8bit of 16bit CRC
CRC Lo	-	1 byte	Lower 8bit of 16bit CRC

※ Frame Size = 5 + Request parameter number x 2

■ **Parameter frame type and form**

Set 1 parameter and command to inverter.

● External transmit frame

Communication number	Command	Parameter	Data	CRC Hi	CRC Lo
----------------------	---------	-----------	------	--------	--------

	Description	Data size	Specifications
Communication number	Target inverter communication number	1 byte	1~32
Command	Frame type	1 byte	0x06
Parameter	Parameter	2 bytes	1 st byte: Group 2 nd byte: Index (Note1)
Data	Data	2 bytes	Setting value (Note 2)
CRC Hi	-	1 byte	Higher 8bit of 16bit CRC
CRC Lo	-	1 byte	Lower 8bit of 16bit CRC

● Inverter response frame

Communication number	Command	Parameter	Data	CRC Hi	CRC Lo
----------------------	---------	-----------	------	--------	--------

	Description	Data size	Specifications
Communication number	Target inverter communication number	1 byte	1~32
Command	Frame type	1 byte	0x06
Parameter	Parameter	2 bytes	1 st byte: Group 2 nd byte: Index (Note1)
Data	Data	2 bytes	Setting value (Note 3)
CRC Hi	-	1 byte	Higher 8bit of 16bit CRC
CRC Lo	-	1 byte	Lower 8bit of 16bit CRC

(Note 1) Parameter setting

1) Basic parameter

Set each group to 1st byte and set the parameter number to 2nd byte.

For example, A60 parameter reading or writing, set 0x03 to 1st byte and 0x3C to 2nd byte.

1 st byte		2 nd byte
Group	Set	Parameter number
d	0x01	
F	0x02	
A	0x03	
B	0x04	
C	0x05	
H	0x06	

Trip information is 4 parameters.
 (output frequency, output current, DC link voltage at trip occurs)

	Trip information (d13)	Previous first trip (d14)	Previous second trip (d15)	Previous third trip (d16)	Trip count (d17)
1 st byte	0x01	0x01	0x01	0x01	0x01
2 nd byte	0x0D	0x11	0x15	0x19	0x1D

※ Trip information data

Trip data	Description	Trip data	Description
1	Over current trip	19	OVS fail
2	Over voltage trip	20	HW power trip 1
3	Under voltage trip	21	HW power trip 2
4	Arm short trip	22	External trip 2
5	Reserved	23	External trip 3
6	Inverter over heat	24	External trip 4
7	Electric thermal trip	25	External trip 5
8	External trip	26	External trip 6
9	EEPROM error	27	Fan trip
10	Communication error	28	Option trip (Profibus)
11	USP trip	29	Option trip (DeviceNet)
12	Ground Fault trip (Over 30kW)	30	System overload trip
15	Input phase loss	31	System underload trip
14	IOLT	32	Keypad communication trip
16	CPU error		
17	Safety function		
18	Braking resistor overload		

(Note 2) Data value setting

Data value is transmitted except decimal point.
 (Please contact to ADT for more details)

Description	Related code	Scale	Remark
Frequency	d01, F01 etc.	0.01	Communication data 6000 Conversion hexadecimal 60 [Hz]
Acc/decel time	F02, F03 etc.	0.1	Communication data 100 Conversion hexadecimal 10 [sec]
Current	d02 etc.	0.1	Communication data 100 Conversion hexadecimal 10[A]

(주3) Special parameter

1) Run command

Parameter frame: 0x0002

Setting data: Forward (0x0001), Reverse (0x0002), Reset (0x0004), Stop (0x0000)

예) Forward run command frame

Description	Comm.no.	Command	Parameter	Data	CRC
Data	0x01	0x06	0x0002	0x0001	0xe9ca

2) Frequency command

Parameter frame: 0x0004

Setting data: Hexadecimal of (Output frequency command * 100)

예) Frequency command (60Hz) frame

Description	Comm.no.	Command	Parameter	Data	CRC
Data	0x01	0x06	0x0004	0x1770	0xc61f

Data additional explanation: 60Hz → 6000(Scale) → 0x1770

(Reference) 16bit CRC generation

The step of CRC generation is as follows:

- 1) All of 16-bit Parameter is 1.0xffff
- 2) The exclusive OR of 16-bit Parameter and 8-bit Parameter.
- 3) Shift right side 1bit 16-bit Parameter
- 4) If the result of step 3 is 1, exclusive OR 16-bit Parameter and 0xa001.
- 5) Execute 8 times step 3 and step 4.
- 6) Execute step 2~6 until data completion.
- 7) Exchange the step 6 result of higher 8bit and lower 8bit.

Example) The case of d01 output frequency reading

Byte 1	Byte 2	Byte 3	Byte 4	Byte 5	Byte 6
Communication number	Command	Parameter		Parameter Number	
0x01	0x03	0x01	0x01	0x00	0x01

The sequence of addition Byte (01x01)

16-BIT REGISTER (Exclusive OR)	MSB				Flag
01	1111	1111	1111	1111	
	0000	0001			
	1111	1111	1111	1110	
Shift 1	0111	1111	1111	1111	
Shift 2	0011	1111	1111	1111	1
Polynomial(0xa001)	1010	0000	0000	0001	
	1001	1111	1111	1110	
Shift 3	0100	1111	1111	1111	
Shift 4	0010	0111	1111	1111	1
Polynomial(0xa001)	1010	0000	0000	0001	
	1000	0111	1111	1110	
Shift 5	0100	0011	1111	1111	
Shift 6	0010	0001	1111	1111	1
Polynomial(0xa001)	1010	0000	0000	0001	
	1000	0001	1111	1110	
Shift 7	0100	0000	1111	1111	
Shift 8	0010	0000	0111	1111	1
Polynomial(0xa001)	1010	0000	0000	0001	
	1000	0000	0111	1110	

Byte 1~6	CRC of operation results
0x01	0x807e
0x03	0x3364
0x01	0x30e1
0x01	0x8831
0x00	0xd449
0x01	0x36d4

Change upper and lower 8 bit of result 0x36d4: 0xd436

Byte7: Upper 8 bit of CRC = 0xd4

Byte8: Lower 8 bit of CRC = 0x36

7. PROTECTIVE FUNCTION

The various functions are provided for the protection of the inverter itself. When the protective function is occurred, motor is stopped as free-run and stay the trip once user reset the inverter.

Name	Cause(s)	Error code
Overcurrent protection	When the inverter output current exceeds the rated current during the motor locked or reduced in speed. Protection circuit activates, halting inverter output.	E04
Overload protection	When the inverter output current causes the motor to overload, the electronic thermal trip in the inverter cuts off the inverter output.	E05
Overvoltage protection	If regenerative energy from the motor or the main power supply voltage is high, the protective circuit activates to cut off the inverter output when the voltage of DC link exceeds the specification	E07
Communication error	Communication error between inverter and its operator. If the Reset signal persists for more than 4 seconds, it will occur.	E60
Under-voltage protection	When input voltage drops below the low-voltage detection level, the control circuit does not function normally. It will cause of overheat of motor and lack of torque that is why if receiving voltage is under 150~160V (200V class) or 300~320V (400V class), the inverter output is cut off.	E09
Output short-circuit	The inverter output was short-circuited. This condition causes excessive current for the inverter that is why, the inverter output is turned off.	E04 or E34
USP error	The USP error is indicated when the power is turned on with the Inverter in RUN state. (Enabled when the USP function selected)	E13
EEPROM	The inverter output is cut off when EEPROM in the inverter has an error due to external noise, excessive temperature rise, or other factors. If the error is occurred, please check setting data again. If error is occurred when power-on and does not off, please turn off the inverter at least 10minutes and power on again.	E08
External trip	When the external equipment or unit has an error, the inverter receives the corresponding signal and cuts off the output.	E12
Temperature trip	When the temperature in the main circuit increases due to cooling fan stop, the inverter output is cut off.	E21
Ground fault	When ground fault is detected on running condition, the output is cut off.	E14
Inverter overload	The power device IGBT is protected from over heat. The operating time of inverter is 1 minute with 150% load of HD or 120% load of ND. The operating time is changed depending on carrier frequency, load, ambient temperature and power rating.	E17
Input phase loss	A function that detects phase loss in the input AC source to prevent damages.	E20
Braking resistor overload protection	When BRD exceeds the usage ratio of the regenerative braking resistor, the over-voltage circuit activates and the inverter output is switched off.	E06
OVS fail	The OVS output frequency is higher than maximum OVS output frequency during the setting time when the OVS function is enabled.	E02
CPU error	It occurred it has error between inverter logic board and I/O board or communication error occurred. Turn off inverter completely, check there is any connection losses then power on.	E11

Name	Cause(s)	Error code
System overload detection fault	The output current of the drive is greater than the detection level set for this feature when it is enabled.	E23
System underload detection fault	The output current of the drive is less than the detection level set for this feature when it is enabled.	E24
FAN fault	The Fan fault is occurred, inverter output is cut off.	E33
Profibus fault (Option)	ProfibusDP optional card only. Host disconnection, or invalid host setting cause this error.	E40
DeviceNet fault (Option)	DeviceNet optional card only. Communication cable power loss, disconnect to host, or invalid host setting cause this error.	E41
HW Power fault 1	It occurred when inverter internal power is problem. Turn off power completely and try power on again.	E50
HW Power fault 2	It occurred when inverter internal power is problem. Turn off power completely and try power on again.	E51
Keypad fault	It occurred keypad communication error. Turn off power completely and try power on again.	E61
External trip 2	When the external equipment or unit has an error, the inverter receives the corresponding signal and cuts off the output. (Need setting for intelligent input terminal)	EE2
External trip 3	When the external equipment or unit has an error, the inverter receives the corresponding signal and cuts off the output. (Need setting for intelligent input terminal)	EE3
External trip 4	When the external equipment or unit has an error, the inverter receives the corresponding signal and cuts off the output. (Need setting for intelligent input terminal)	EE4
External trip 5	When the external equipment or unit has an error, the inverter receives the corresponding signal and cuts off the output. (Need setting for intelligent input terminal)	EE5
External trip 6	When the external equipment or unit has an error, the inverter receives the corresponding signal and cuts off the output. (Need setting for intelligent input terminal)	EE6

Other display

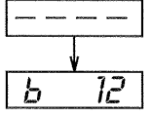
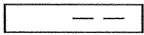
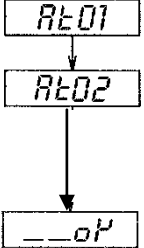
Contents	Display
<p>It is displayed when initialization of data is processing (It is not displayed when initialization of history is processing.)</p>	
<p>There is no data available (Trip history, PID feedback data)</p>	
<p>The auto-tuning operation terminates normally</p>	

8. TROUBLESHOOTING TIPS

Symptom		Probable Cause	Countermeasure
The motor will not move	The inverter outputs U, V and W are not supplying voltage	<ul style="list-style-type: none"> •Is the frequency command source A01 parameter setting correct? •Is the Run command source A02 parameter setting correct? 	<ul style="list-style-type: none"> •Make sure the parameter A01 setting correct? •Make sure the parameter A02 setting correct?
		<ul style="list-style-type: none"> •Is power being supplied to terminals R, S and T? If so, the power lamp should be on. 	<ul style="list-style-type: none"> •Check terminals R, S and T then U, V, and W. •Turn on the power supply/
		<ul style="list-style-type: none"> •Is there an error code E□□ displayed? 	<ul style="list-style-type: none"> •Press the Func key and determine the error types. Then clear the error (Reset).
		<ul style="list-style-type: none"> •Are the signals to the intelligent input terminals correct? •Is the Run Command active? •Is the [FW] terminal (or [RV] connected to CM1 (via switch, etc.) 	<ul style="list-style-type: none"> •Verify the terminal functions for C01-C06 are correct. •Turn on Run Command •Supply 24V to [FW] or [RV] terminal, if configured. (Terminal mode selection)
		<ul style="list-style-type: none"> •Has the frequency setting for F01 been set greater than zero? •Are the control circuit terminals H, O, and L connected to the potentiometer? 	<ul style="list-style-type: none"> •Set the parameter for F01 to a safe, non-zero value. •If the potentiometer is the frequency setting source, verify voltage at "O" > 0V
		<ul style="list-style-type: none"> •Is the RS(reset) function or FRS (free-run stop) function on? 	<ul style="list-style-type: none"> • Turn off the command(s)
	Inverter outputs U, V, W are supplying voltage	<ul style="list-style-type: none"> •Is the motor load too heavy? •Is the motor locked? 	<ul style="list-style-type: none"> •Reduce load, and test the motor independently.
The direction of the motor is reversed		<ul style="list-style-type: none"> •Are the connections of output terminal U, V, and W correct? •Is the phase sequence of the motor forward or reverse with respect to U, V, and W? 	<ul style="list-style-type: none"> •Make connections according to the phase sequence of the motor. In general: FWD=U-V-W REV=U-W-V
		<ul style="list-style-type: none"> •Are the control terminals [FW] and [RV] wired correctly? •Is parameter F04 properly set? 	<ul style="list-style-type: none"> • Use terminal [FW] for [RV] is reverse.
The motor speeds will not reach the target frequency		<ul style="list-style-type: none"> • If using the analog input, is the current or voltage at "O" or "OI"? 	<ul style="list-style-type: none"> •Change the wiring
		<ul style="list-style-type: none"> • Is the load too heavy? 	<ul style="list-style-type: none"> •Reduce the load. •Heavy loads activate the overload restriction feature.

Symptom		Probable Cause	Countermeasure
The rotation is unstable		<ul style="list-style-type: none"> •Is the load fluctuation too great? •Is the supply voltage unstable? •Is the problem occurring at a particular frequency? 	<ul style="list-style-type: none"> •Increase the motor capacity (both inverter and motor) •Fix power supply problem. •Change the output frequency slightly, or use the jump frequency setting to skip the problem frequency.
The RPM of the motor does not match the inverter output frequency setting		<ul style="list-style-type: none"> •Is the maximum frequency setting A04 correct? 	<ul style="list-style-type: none"> •Verify the V/F settings match motor specifications •Make sure all scaling is properly set
Inverter data is not correct	No down-Load shave occurred	<ul style="list-style-type: none"> •Was power turned off after a parameter edit but before pressing the store key? 	<ul style="list-style-type: none"> •Edit the data and press the store key once
		<ul style="list-style-type: none"> •Edits to data are permanently stored at power down. Was the time from power off to power on less than six seconds? 	<ul style="list-style-type: none"> •Wait six seconds or more before turning power off after edit data.
A parameter is not change	The frequency setting will not change. Run/Stop does not operate	<ul style="list-style-type: none"> •Was the standard operator mode and terminal mode changed correctly? 	<ul style="list-style-type: none"> •Make sure the setting mode of [A01], [A02] (Refer to 5-4)
	Parameter is not change	<ul style="list-style-type: none"> •Is the SFT setting selected? SFT (b09 -2,3) selected? 	<ul style="list-style-type: none"> •Turn off SFT function and check the b09 parameter. (b09=0)

9. MAINTENANCE AND INSPECTION

Regularly perform maintenance and inspection. Failure to carry out regular maintenance checks will result in failure in some cases.

 <b style="font-size: 1.2em; margin-left: 10px;">DANGER
<ul style="list-style-type: none"> • Wait at least ten (10) minutes after turning off the input power supply before performing maintenance of an inspection. Otherwise, there is the danger of electric shock. • Make sure that only qualified personnel will perform maintenance, inspection, and part replacement. (Before starting to work, remove any metallic objects wristwatch, bracelet, etc.) Otherwise, there is a danger of electric shock and/or injury.

9.1 General precautions and notes

Always keep the unit clean so that dust of other foreign matter does not enter the inverter.

Firmly connect terminals and connectors.

Keep electronic equipment away from moisture and oil. Dust, steel filings and other foreign matter can damage insulation, causing unexpected accidents, so take special care.

When removing connectors, never pull the wires (wires for the cooling fan and logic P.C. board.)

Otherwise, there is danger of fire due to wire breakage and/or injury

9.2 Inspection items

- (1) Daily inspection
- (2) Periodic inspection (approximately once a year)
- (3) Insulation resistance test (approximately once two years)

Conduct the insulation resistance test by short circuiting the terminals as shown below.

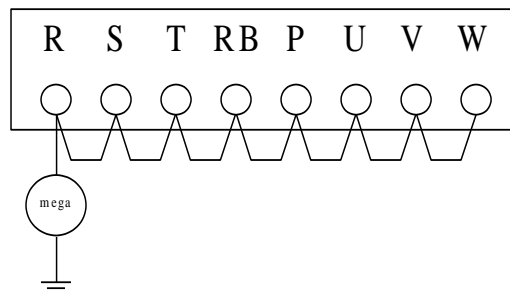

- Measure the above terminals and ground clearance with a 500 V mega tester and check if it is more than 5 MΩ.

We recommend that you stock spare parts to reduce down time, which include

Recommend spare parts for stocks

Parts	Symbol	Quantity		Note
		Used	Spare	
Cooling Fan	FAN	1~2	1~2	Depends on power range 1EA: 007SF~2.2SF, 007LF~037LF, 007HF~037HF, 055LF/075LFP~075LF/110LFP 055HF/075HFP~075HF/110HFP 2EA: 110LF/150LFP~150LF/185LFP 110HF/150HFP~220HF/300HFP
Case	-	1	1	Front case Main case Bottom case

Inverter electrical measurements

The following table specifies how to measure key system electrical parameters. The diagrams on the next page show inverter-motor systems the location of measurement points for these parameters.

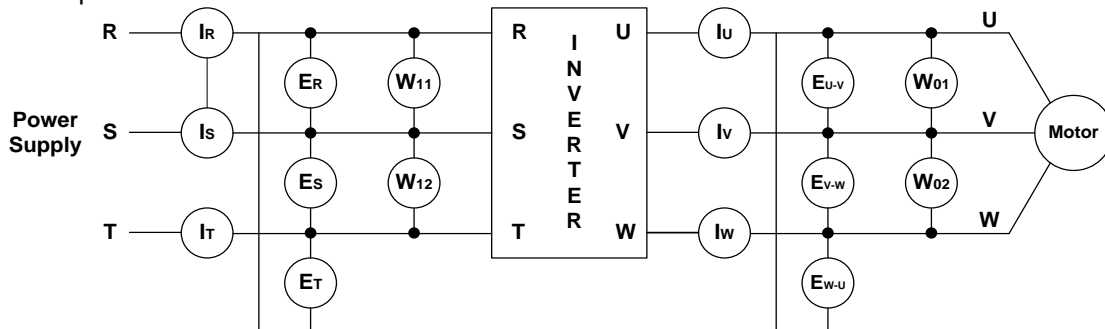

Parameter	Measurement location	Measuring instrument	Notes	Reference value
Supply voltage E1	R-S, S-T, T-R (ER) (ES) (RT)	⚡ Moving-coil type voltmeter * type voltmeter	Fundamental wave effective value	Commercial supply voltage (200V class) 200-220V 50Hz 200-240V 60Hz (400V class) 380-415V 50Hz 400-480V 60Hz
Supply current I1	R S T current (IR) (IS) (IT)	⚡ Moving-coil type ammeter	Total effective value	
Supply power W1	R-S, S-T (W11) + (W12)	⚡ Electronic type wattmeter	Total effective value	2wattmeter method
Supply power factor Pf1	Calculate the output power factor from the output voltage E1, output current I1, and output power W1. $P_{f1} = \frac{W_1}{\sqrt{3} \times E_1 \times I_1} \times 100(\%)$			
Output voltage E0	U-V, V-W, W-U (EU) (EV) (EW)	* Rectifier type voltmeter	Total effective value	
Output current I0	U, V, W current (IU) (IV) (IW)	⚡ Moving-coil type ammeter	Total effective value	
Output power W0	U-V, V-W (W01) + (W02)	⚡ Electronic type wattmeter	Total effective value	2wattmeter method
Output power factor Pf0	Calculate the output power factor from the output voltage E0, output current I0, and output power W0. $P_{f0} = \frac{W_0}{\sqrt{3} \times E_0 \times I_0} \times 100(\%)$			

Use a meter indicating a fundamental wave effective value for voltage, and meters indicating total effective values for current and power.

The inverter output has a PWM waveform, and low frequencies may cause erroneous readings. However, the measuring instruments and methods listed above provide comparably accurate results.

A general-purpose digital volt meter (DVM) is not usually suitable to measure a PWM waveform.

